

**Models 500 / 600
Commercial Condensing
Gas-Fired Water Boilers**

Boiler Manual



⚠ WARNING

Installation and service of the boiler must be performed by a qualified installer or service technician. Read all instructions, including this manual and all other information shipped with the boiler, before installation or operation. Perform steps in the order given. Failure to comply can result in severe personal injury, death, or substantial property damage.

Contents

Abbreviations 4

Tools 4

SECTION 1 – SAFETY 5

Safety Signals 5

Please Read Before Proceeding 5

 Boiler Operation 6

 Boiler Water 6

 Freeze Protection Fluids 6

 Damage from Water Contact 6

 Frozen Water Damage 7

SECTION 2 – INSTALLATION 9

Prepare Boiler Location 9

 Installation Compliance Requirements 9

 Checks Before Boiler Installation 9

 Flooring and Foundation 10

 Garage Installation 10

 Openings 10

 Clearances 11

 Air Openings 12

 Preparing for Multiple Boilers 13

Prepare the Boiler 14

 Removing the Boiler from the Crate 14

 Placing the Boiler 15

 Bolting the Boiler to Mounting Blocks 15

 Propane Conversion Procedure (when required) 16

 High Altitude Installations 17

 Pressure Test Preparation 17

 Fill the Boiler 17

 Pressure Test Precautions 18

 Perform Hydrostatic Pressure Test 18

Install Water Piping 19

 General Piping Information 19

 Pressure and Temperature Gauge 19

 Relief Valve Installation 20

 Pipe Sizing 21

 Expansion Tank and Make-up Water 22

 Diaphragm or Bladder Expansion Tank 22

 Closed-Type Expansion Tank 22

 ZONE VALVE Zoning - General 23

 ZONE VALVE Zoning - Primary/Secondary 24

 ZONE VALVE Zoning - High-flow-rate or High-head-loss DHW Circuits 24

 ZONE VALVE Zoning - Variable Primary Flow 25

 ZONE VALVE Zoning - Circulator Zoning, Primary/Secondary 26

 ZONE VALVE Zoning - Radiant Heating, Primary/Secondary 26

 ZONE VALVE Zoning - Water Chiller Systems, Primary/Secondary 27

Commonwealth of Massachusetts Installations 28

Venting and Combustion Air — General 29

 Code Compliance 29

 Venting Methods 29

 Vent and Air Piping 29

 Boiler Categories 29

 Using a Chimney 30

 Combustion Air Contamination 30

 Vent and Air Adapters 31

 PVC Piping 31

Venting and Combustion Air Options 32

 Existing Vent System 32

 Existing Vent System Test Procedure 32

 Vent and Air Piping Materials 33

 Category II Requirements 34

 Vent and Air Terminations for Category IV 36

Room Air Openings 37

 Combustion Air Provision — Direct Exhaust 37

 Combustion Air Provision — Direct Vent 37

 Sizing Combustion Air Openings 37

 Special Considerations 37

 Combustion Air Manifold Option — 40

DIRECT EXHAUST — Vertical Termination (Cat. II and IV) . 41

 Vertical Termination Location 41

 Multiple Vent Terminations 41

 Vent Piping Installation 42

 Vent Termination Installation 42

DIRECT EXHAUST — Sidewall Termination (Category IV) . 43

 Sidewall Termination Location 43

 Determine Termination Location 44

 Multiple Vent Terminations 44

 Vent Piping Installation 44

 Vent Termination Installation 45

DIRECT VENT — Vertical Termination (Category IV) . 46

 Vertical Termination Location 46

 Multiple Vent Terminations 46

 Vent Piping Installation 46

 Vent and Air Termination Installation 47

DIRECT VENT — Sidewall Separate Pipes (Category IV) . 49

 Sidewall Termination Location 49

 Determine Termination Location 50

 Multiple Vent Terminations 50

 Vent Piping Installation 51

 Vent Termination Installation 51

DIRECT VENT — Vertical Concentric (Category IV) . 52

 Determine Termination Location 52

 Multiple Vent and Air Inlet Terminations 52

 Concentric Piping Termination Installation 52

 Vent Piping Installation 53

Concentric Termination, Typical 54

DIRECT VENT — Sidewall Concentric (Category IV) . 55

 Determine Termination Location 55

 Multiple Vent and Air Inlet Terminations 55

 Concentric Piping Termination Installation 56

 Vent Piping Installation 57

DIRECT VENT — Sidewall Vent and Air Plate (Category IV) . 58

 Determine Termination Location 58

 Multiple Vent Terminations 58

 Vent and Air Plate Installation 59

 Vent Piping Installation 60

Install Condensate Components 61

 Condensate Trap Installation 61

 Condensate Line Connection 61

Gas Piping 62

 Gas Supply Piping Connection 62

 Check Natural or LP Gas Supply Pressure 63



Gas Train Diagram	63	Maximum and Minimum Final Check	100
Pipe Sizing for Natural Gas	64	Check Ignition System Safety Shutoff Device	100
Pipe Sizing for Propane Gas	64	Check the System for Leaks	100
Multiple Boiler Applications - Manifolder Gas Supply Lines	64	Gas Valve Leakage Testing	101
Gas Pressure Switches	64	Verification Check List	102
SECTION 3 – ELECTRICAL	65	SECTION 5 – MAINTENANCE	103
Electrical – General	65	Maintenance — General	103
Power Requirements	65	Handling Ceramic Fiber Materials	103
Field Wiring	66	Perform Startup and Checkout	103
Terminal Connections	66	Annual Inspection	104
Wiring Overview	66	First-Year Special Inspection	104
Wire Entrances	66	General Inspection Information	105
Wire Routing in the Cabinet	66	Inspect the Boiler Area	105
Schematic Diagram	68	Inspect the Boiler Interior and Jacket Door Gaskets	105
Ladder Diagram	70	Inspect and Clean the Condensate Trap	105
Terminal Block Wiring	72	Inspect All Piping for Leaks	105
Zoning with the Control	80	Service and Maintenance Schedules	106
SECTION 4 – OPERATION	83	Annual Startup	107
Control Setup and Operation	83	Check Air Openings	107
Control Overview	83	Flue Vent System and Air Piping	107
Control Setup	83	Check the Water System	107
Control Features	84	Check the Boiler Relief Valve	107
Sequence of Operation	85	Check the Expansion Tank	108
Control Priorities, Inputs, and Outputs	85	Inspect the Ignition Electrode and Wiring	109
Control WIZARD	85	Inspect and Clean the Burner	110
Control Operation	86	Inspect the Combustion Chamber	110
Outdoor Temp for Min Target	86	Cleaning the Heat Exchanger - Water Side	111
Outdoor Temp for Max Target	86	Cleaning the Heat Exchanger - Flue Side	111
Outdoor Reset Operation	86	Reinstalling All Components	112
Remote Target Operation	87	Inspecting the High Flue Pressure Switch	114
Remote Modulation Operation	87	Replacing the Flue Pressure Switch	114
Variable Speed Boiler Pumping	87	Check Boiler Wiring and Control Settings	114
Essential Control Settings	88	Perform Startup and Checks	114
Control Settings Menus	89	Low Water Cut-Off Test	114
Connecting the Boiler	90	Check the Burner Flame	115
Contractor Menus	91	Check the Flame Signal	115
Service Menus	91	Check the Flue Gas Temperature	116
Startup — Fill the System	92	Check Blower Speeds	116
Clean the System	92	High Altitude	116
Water Chemistry	92	Manual Test Mode	118
Freeze Protection	93	Reinstall the Jacket Door After Servicing	118
Antifreeze	93	Review with the Owner	118
Fill and Test the Water System	94	SECTION 6 – TROUBLESHOOTING	119
Recommended Inhibitor	94	Troubleshooting — General	119
Purge Air from the Water System	94	Diagnosing Boiler Issues	119
Check Concentrations Annually	94	Checking the Boiler	119
Startup — Final Checks	95	Checking the Control Fuses	120
Check for Gas Leaks	95	Checking the In-Line Fuses	121
Check Thermostat Circuits	95	Checking the Temperature Sensors	121
Inspect and Fill the Condensate System	95	Errors and Lockouts	122
Inspect the Pressure Switch Hose	96	Control Fault Indications	122
Final Checks Before Starting the Boiler	96	Fault History Log	122
Startup Procedure	98	Resetting the Control	122
Starting the Boiler	98	Fault and Action Items	124
Troubleshooting Startup Issues	98		
Check Flame and Combustion	98		
Gas Valve Adjustment	99		

(continued on the next page)

Contents, continued

SECTION 7 – PARTS 131
 Miscellaneous Parts 131
 Ordering 131
 The SVF Commercial Condensing Water Boiler. 132
 Replacement Parts 134
 Dimensions 140

SECTION 8 – SERVICE INFORMATION 141
 Ratings 141
 Read Configuration Settings 143
 Bluetooth Connection. 143
 Saving the Boiler Configuration 143
 Maintenance Log 145
 Installation and Service Certificate. 146
 Notes 146

Abbreviations

Table 1 Common abbreviations

Abbreviation	Description
AHD	Additional Heat Demand
AMP	Ampere or Amperage
ANSI	American National Standards Institute
ASME	American Society of Mechanical Engineers
BMS	Building Management System
BTUH	British Thermal Unit per Hour
CAD	Combustion Air Damper
CH	Comfort Heat
CO	Carbon Monoxide
CO ₂	Carbon Dioxide
CP	Consumer Protection
CPVC	Chlorinated Polyvinyl Chloride
CSA	Canadian Standards Association
CSD-1	Controls and Safety Devices
DHW	Domestic Hot Water
LP	Liquefied Petroleum (Propane)
LWCO	Low Water Cut-Off
MBH	Thousands of Btuh
NFPA	National Fire and Protection Agency
NG	Natural Gas
NIOSH	National Institute for Occupational Safety and Health
NTC	Negative Temperature Coefficient
O ₂	Oxygen
ODT	Outdoor Temperature
PP	Polypropylene
P/T	Pressure and Temperature
RPM	Revolutions Per Minute
SCFM	Standard Cubic Feet per Minute
SS	AL29-4C Stainless Steel
TB<#>	Terminal Block (1, 2, 3, etc.)
ULC	Underwriters Laboratories of Canada
Vac	Volts Alternating Current
Vdc	Volts Direct Current
W.C.	Water Column

Tools

Table 2 Common tools needed

Tools Needed	Purpose
1/16" flat blade screwdriver	Wiring on terminal blocks. Removing the throttle screw cover.
3/16" Allen wrench	Removing gas valve pressure tap plugs.
5/16" socket	Removing the control panel cover.
T40 bit	Removing the offset cover and adjusting the offset screw.
3 mm Allen wrench	Adjusting the throttle screw. Removing the sight glass, igniter, or flame sense rod.
4 mm Allen key	Removing the venturi from the gas train. Removing the burner access plate.
5 mm Allen key	Removing the cover plate to access heat exchanger interior.
8 mm socket or wrench	Removing cover plate insulation.
10 mm socket or wrench	Removing the burner.
11 mm socket or wrench	Removing the venturi from the silencer.
13 mm wrench	Removing the blower.
Multimeter	Measurement readings on sensors and electrical components.
Manometer (inclined or digital)	Measuring the gas pressure coming to the boiler.
Combustion analyzer (digital preferred)	Combustion testing.
Contact thermometer	Checking surface temperatures of the heat exchanger and pipes.



SECTION 1

Safety

This section is intended to provide safety information.

Section Contents

Safety Signals	5
Please Read Before Proceeding	5

Safety Signals

The following defined terms are used throughout this manual to bring attention to the presence of hazards or other important information.

⚠ DANGER

Danger indicates the presence of hazards that will result in severe personal injury, death, or substantial property damage.

⚠ WARNING

Warning indicates the presence of hazards that can result in severe personal injury, death, or substantial property damage.

⚠ CAUTION

Caution indicates the presence of hazards that will or can result in minor personal injury or property damage.

NOTICE

Notice indicates additional information that may be related to property damage, but is not related to personal injury.

IMPORTANT

Important indicates additional information that is important, but is not related to personal injury or property damage.

Please Read Before Proceeding

⚠ WARNING

Adhere to all following guidelines and instructions in this section. Failure to adhere to these guidelines can result in severe personal injury, death, or substantial property damage.

Installer: Read all instructions, including this manual and all other information shipped with the boiler, before installation. Perform steps in the order given. Consider piping and installation when determining boiler location.

Write the Consumer Protection (CP) number and serial number in the space provided on the Installation and Service Certificate on [page 146](#). The CP number can be found on the boiler jacket.

Please include the boiler model number, CP number, and serial number when calling or writing about the boiler. The model number can be found on the boiler rating label.

User: This manual is for use only by a qualified heating installer or service technician. Refer to the User Manual (part number 550-100-274) for your reference. A qualified service technician should inspect and service this boiler at least once per year.

IMPORTANT

Any claims for damage or shortage in shipment must be filed immediately against the transportation company by the consignee.



Please Read Before Proceeding, continued

Servicing a Boiler

- To avoid electric shock, disconnect all electrical supplies to the boiler before performing maintenance.
- To avoid severe burns, allow boiler to cool before performing maintenance.
- This boiler contains ceramic fiber and fiberglass materials. Refer to the warning and instructions on [page 103](#).

Boiler Operation

- Do not block flow of combustion or ventilation air to boiler.
- Should overheating occur, or gas supply fail to shut off, do not turn off or disconnect electrical supply to pump. Shut off the gas supply at a location external to the appliance.

Boiler Water

- Since the heat exchanger is made of stainless steel, the water chemistry must be checked. The system pH must be in the range of 7.0 to 8.5. Chemical treatment may be required. See [pages 92 to 94](#) for details.
- Before connecting the boiler, thoroughly flush the system to remove sediment. Install a strainer or other sediment removal equipment if necessary. The high-efficiency heat exchanger can be damaged by build-up or corrosion due to sediment.
- Do not use petroleum-based cleaning or sealing compounds in the boiler system. Gaskets and seals in the system may be damaged, which can result in substantial property damage.
- Continual fresh make-up water will reduce boiler life. Mineral buildup in the heat exchanger reduces heat transfer, overheats the stainless steel heat exchanger, and causes failure. Addition of oxygen carried in by make-up water can cause internal corrosion. Leaks in the boiler or piping must be repaired at once to prevent make-up water. Use this boiler **ONLY** in a closed-loop system.
- Do not add cold water to a hot boiler. Thermal shock can cause the heat exchanger to crack.

Commonwealth of Massachusetts

When the boiler is installed within the Commonwealth of Massachusetts:

- This product must be installed by a licensed plumber or gas fitter.
 - If antifreeze is used, a reduced pressure back-flow preventer device shall be used.
- See [page 28](#) for sidewall vent air installations.

Freeze Protection Fluids

NEVER use automotive or standard glycol antifreeze, including glycol made for hydronic systems. Use only freeze-protection fluids recommended in this manual. See [page 93](#) for more information. Thoroughly clean and flush any replacement boiler system that has used glycol before installing the new SVF boiler.

Damage from Water Contact

⚠ DANGER

DO NOT attempt to operate any boiler if any part of the boiler, burner, or controls has been partially or fully sprayed with or submerged under water. The boiler must either be replaced or completely repaired and inspected. The boiler and all components must be in good condition and fully reliable before operation.

If these requirements are not met, operating the boiler will cause fire, explosion, and electrical shock hazards, which will result in serious injury, death, or substantial property damage.

Saltwater damage: The immediate effects of saltwater damage are like those of freshwater, with electrical components shorting out and the removal of critical lubricants. However, salt and other contaminants left behind can lead to long term issues due to the conductive and corrosive nature of salt residue. WM Technologies equipment contaminated with saltwater or polluted water will no longer be covered under warranty and should be replaced.

Electrical damage: If any electrical component or wiring has, or is suspected to have come into contact with water, replace the boiler.

Frozen Water Damage

Power outages, unattended residences or buildings, boiler component failures, or other electrical system failures in cold weather can result in frozen plumbing and water damage in a matter of hours. Consult with a boiler contractor or a home security agent to take preventative actions, such as installing a security system that operates during power outages, senses low temperature, and initiates an effective action.

This page intentionally left blank

SECTION 2

Installation

This section is intended to provide installation instructions for qualified heating installers.

Section Contents

Prepare Boiler Location	9
Prepare the Boiler	14
Install Water Piping	19
Commonwealth of Massachusetts Installations	28
Venting and Combustion Air — General	29
Venting and Combustion Air Options	32
Room Air Openings	37
DIRECT EXHAUST — Vertical Termination (Cat. II and IV)	41
DIRECT EXHAUST — Sidewall Termination (Category IV)	43
DIRECT VENT — Vertical Termination (Category IV)	46
DIRECT VENT — Sidewall Separate Pipes (Category IV)	49
DIRECT VENT — Vertical Concentric (Category IV)	52
Concentric Termination, Typical	54
DIRECT VENT — Sidewall Concentric (Category IV)	55
DIRECT VENT — Sidewall Vent and Air Plate (Category IV)	58
Install Condensate Components	61
Gas Piping	62

Prepare Boiler Location

Installation Compliance Requirements

⚠WARNING

Installation and service must be performed by a qualified installer, service agency, or gas supplier. Install the equipment in accordance with this manual to avoid an unsafe operating condition, which can result in severe personal injury, death, or substantial property damage.

- Local, state, provincial, and national codes, laws, regulations, and ordinances.
- National Fuel Gas Code – ANSI Z223.1/NFPA 54, latest edition.
- National Electrical Code – ANSI/NFPA 70, latest edition. For Canada, electrical installation and grounding must be in accordance with Canadian Electrical Code, Part 1 – CSA C22.1, and local codes.

- For Canada only: Natural Gas and Propane Installation Code – CAN/CSA B149.1, and local codes.
- Where required by the authority having jurisdiction, the installation must conform to the Standard for Controls and Safety Devices for Automatically Fired Boilers – ANSI/ASME CSD-1, latest edition.

IMPORTANT

The SVF boiler manifold and controls meet safe lighting and other performance criteria when the boiler underwent tests specified in ANSI Z21.13, latest edition.

Checks Before Boiler Installation

1. Check for nearby connections to:
 - System water piping
 - Venting connections
 - Gas supply piping
 - Electrical Power
 - Location of drain for condensate
2. Check area around boiler. Remove any combustible materials, gasoline, and other flammable liquids.

⚠WARNING

Failure to keep boiler area clear and free of combustible materials, gasoline, and other flammable liquids and vapors can create an explosion hazard, which can result in severe personal injury, death, or substantial property damage.

3. Check the boiler location to ensure it protects the gas control system components from dripping or spraying water and rain during operation or service.
4. If a new boiler is replacing the existing boiler, check for and correct system problems:
 - System leaks causing oxygen corrosion or heat exchanger cracks from hard water deposits.
 - Incorrect expansion tank sizing.
 - Lack of freeze protection in boiler water.



Prepare Boiler Location, continued

Flooring and Foundation

The SVF Boiler is approved for installation on combustible flooring, but must never be installed on carpeting.

⚠ WARNING

Do not install the boiler on carpeting even if a foundation is used. Installing a boiler on carpeting can cause a fire, which can result in severe personal injury, death, or substantial property damage.

1. The boiler mounting surface must be level and suitable for the load.
2. Provide a solid foundation pad at least 2" (51 mm) above the floor if any of the following is true:
 - Floor can become flooded.
 - The floor is dirt, sand, gravel, or other loose material.
 - The boiler mounting area is severely uneven or sloped.
3. Foundation may be brick or concrete construction. The minimum foundation dimensions are listed in Table 3.
4. If flooding is possible, elevate the boiler sufficiently to prevent water from reaching the boiler.

Garage Installation

Take the following special precautions when installing the boiler in a garage.

1. Mount the boiler at a height above the floor as specified in the latest edition of the National Fuel Gas Code – ANSI Z223.1/NFPA 54 for U.S. installations. For Canadian installations, use the Natural Gas and Propane Installation Code – CAN/CSA B149.1.
2. Locate or protect the boiler so it cannot be damaged by a moving vehicle.
3. Ensure that the installation complies with all applicable codes.

Table 3 Minimum foundation dimensions

Boiler Model	Minimum Dimensions (inches)
SVF 500	29 x 44 x 2
SVF 600	29 x 44 x 2

Openings

Openings in floors, walls, ceilings, or roofs must be designed for fire stopping as required by local codes.

Vent pipe openings through combustible materials must be 3/8" (9.5 mm) larger in diameter than the vent pipe.

Air pipe openings should be 3/8" (9.5 mm) larger in diameter than the pipe or as required by the pipe manufacturer.

⚠ WARNING

Pipe openings that do not have the required diameter can cause a fire, which can result in severe personal injury, death, or substantial property damage.

Provide air openings for combustion air and ventilation of the room. See [page 12](#) for more information.

Clearances

Hot water pipes, vent pipes, and piping ends all have a minimum clearance requirement from combustible surfaces. There are also minimum allowable service clearances and recommended service access clearances. See Figure 1 for all clearances.

IMPORTANT

Without the recommended minimum clearances for service access, it may not be possible to service the boiler without removing it from the space.

Figure 1 Clearances for SVF Boilers

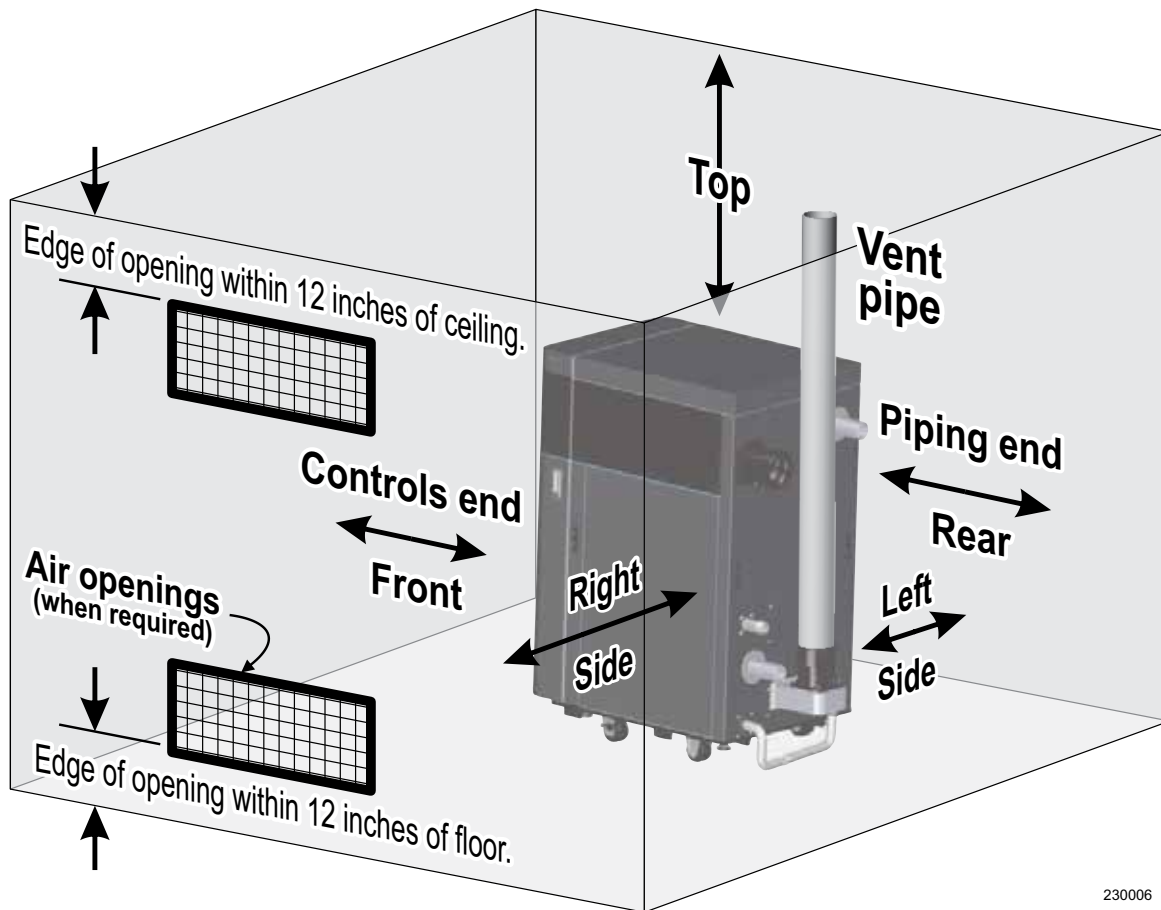

230006

Ensure that the installation complies with all state, local, and applicable codes.			
Clearance from:	Minimum clearances to combustible surfaces (inches)	Minimum allowable service clearances (inches)	Recommended minimum service access clearances (inches)
Controls end (Front)	0	24	35
Left side	0	0*	24*
Right side	0	0*	24*
Piping end	18	18	35 (Measured from frame, not pipes)
Top	0	18**	18**
Floor	0	—	—
Vent pipe	3/16	—	—
Hot water pipes	1/2	—	—

* Boiler can be installed next to another boiler. Clearances shown allow for easier service and maintenance.
 ** Top clearance allows for access to the cover plate for burner and heat exchanger service.

Prepare Boiler Location, continued

Air Openings

Follow the National Fuel Gas Code – ANSI Z223.1/ NFPA 54, latest edition, for the U.S. Follow the Natural Gas and Propane Installation Code – CAN/CSA B149.1 for Canada.

Follow all applicable codes to size and verify size of the combustion and ventilation air openings into the space.

The SVF boiler requires a special vent system. See the Venting and Combustion Air sections starting on [page 29](#) for more information on the venting methods, and the required air openings and sizing for direct vent or direct exhaust installations.

SVF Boiler Alone in Boiler Room:

Direct Vent installations: No air ventilation openings into boiler room are needed if the clearances around the boiler are at least equal to the recommended service clearances shown in [Figure 1, page 11](#). For spaces that do not supply the recommended minimum service access clearances, see the Room Air Openings section, starting on [page 37](#) for required openings.

Direct Exhaust installations: Provide air openings as specified in the Room Air Openings section, starting on [page 37](#).

SVF Boiler in a Room With Other Appliances:

Direct Vent installations: Size openings only on the basis of the other appliances in the space. No additional air opening free area is needed for the SVF boiler because it takes its combustion air from outside.

▲WARNING

For direct vent installations where the boiler is located in the same room as other appliances, provide combustion air openings correctly sized for all appliances in the room EXCEPT the SVF boiler. Failure to comply can result in severe personal injury, death, or substantial property damage.

Direct Exhaust installations: Combustion air openings into the room must be sized to handle the SVF boiler and all other appliances. See the Room Air Openings section starting on [page 37](#) for required openings.

The boiler control has the ability to operate a combustion air damper. Refer to section J on [page 76](#) and the SVF Advanced Manual (part number 550-100-207).

▲WARNING

For direct exhaust installations, provide combustion air openings correctly sized for all appliances in the room, INCLUDING the SVF boiler. Failure to comply can result in severe personal injury, death, or substantial property damage.

Preparing for Multiple Boilers

1. Provide the clearances shown in Figure 2 and follow local codes. Other layouts can be used if all required clearances are maintained.
2. Construct boiler foundation if the floor in the boiler room is uneven or if there is the probability of flooding. Size foundation to allow for clearance and spacing dimensions shown in the figure below.
3. Chalk-line boiler locations on foundation or boiler room floor.
4. Remove boilers from the crate and assemble according to instructions in this manual.
5. Provide clearance for installation of venting, air piping, gas piping, condensate piping and components, expansion tank, boiler pump, and other accessories as given in [Figure 1, page 11](#).

Figure 2 Side-to-side mounting of multiple boilers

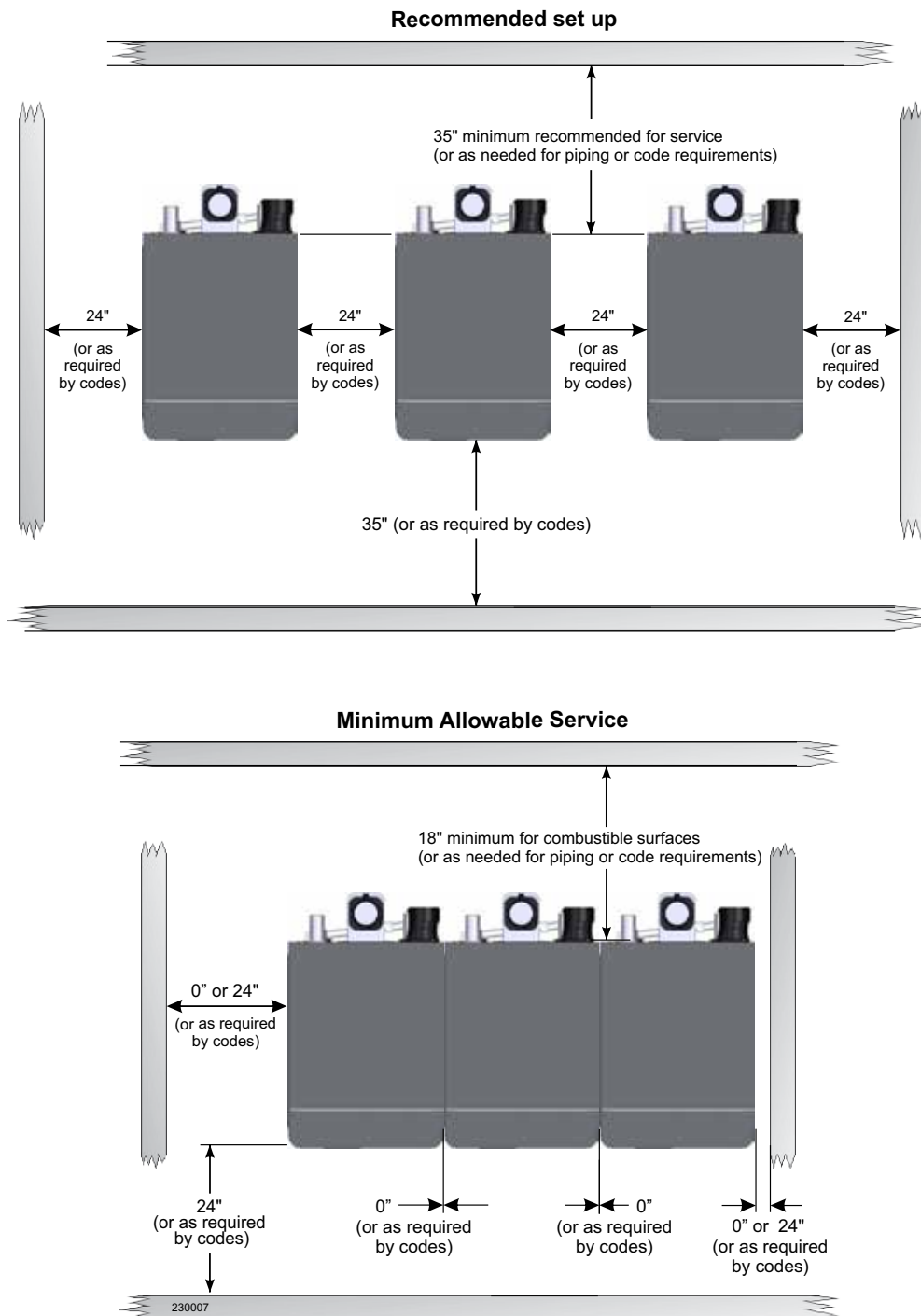

Prepare the Boiler

Removing the Boiler from the Crate

Leave the boiler in the crate pallet until ready to place in the final location. Follow all uncrating instructions. Refer to Figure 3 for the following instructions.

NOTICE

If the boiler has been stored in a location with temperatures below 32°F (0°C), handle with care until the plastic components come to room temperature.

NOTICE

Leave the plastic covers on the connections and adapters until ready to attach piping. This will protect the fitting surfaces from damage and prevent debris from entering the vent or air adapters.

1. Move the crate to a solid, level surface. The crate must sit securely on the ground. Ensure there is sufficient clearance for the crate, ramp, and final boiler placement on the floor in front of the piping.

⚠ WARNING

The boiler is heavy. Use caution not to drop the boiler. Use proper lifting equipment and techniques. Do not lift the boiler with water or gas pipes. Do not handle, apply weight to, or push on the gas pipes. Failure to comply can result in severe personal injury, death, or substantial property damage.

2. Remove the ramp from the crate. Place the end of the ramp into the notch in the pallet as show in Figure 3. Follow the uncrating instruction label to secure the ramp to the pallet.
3. Remove board at ramp end that states “REMOVE TO UNLOAD” with crowbar or claw hammer.
4. Remove the eight screws and eight lag bolts from the four shipping brackets.

Figure 3 SVF boiler on pallet with ramp in position

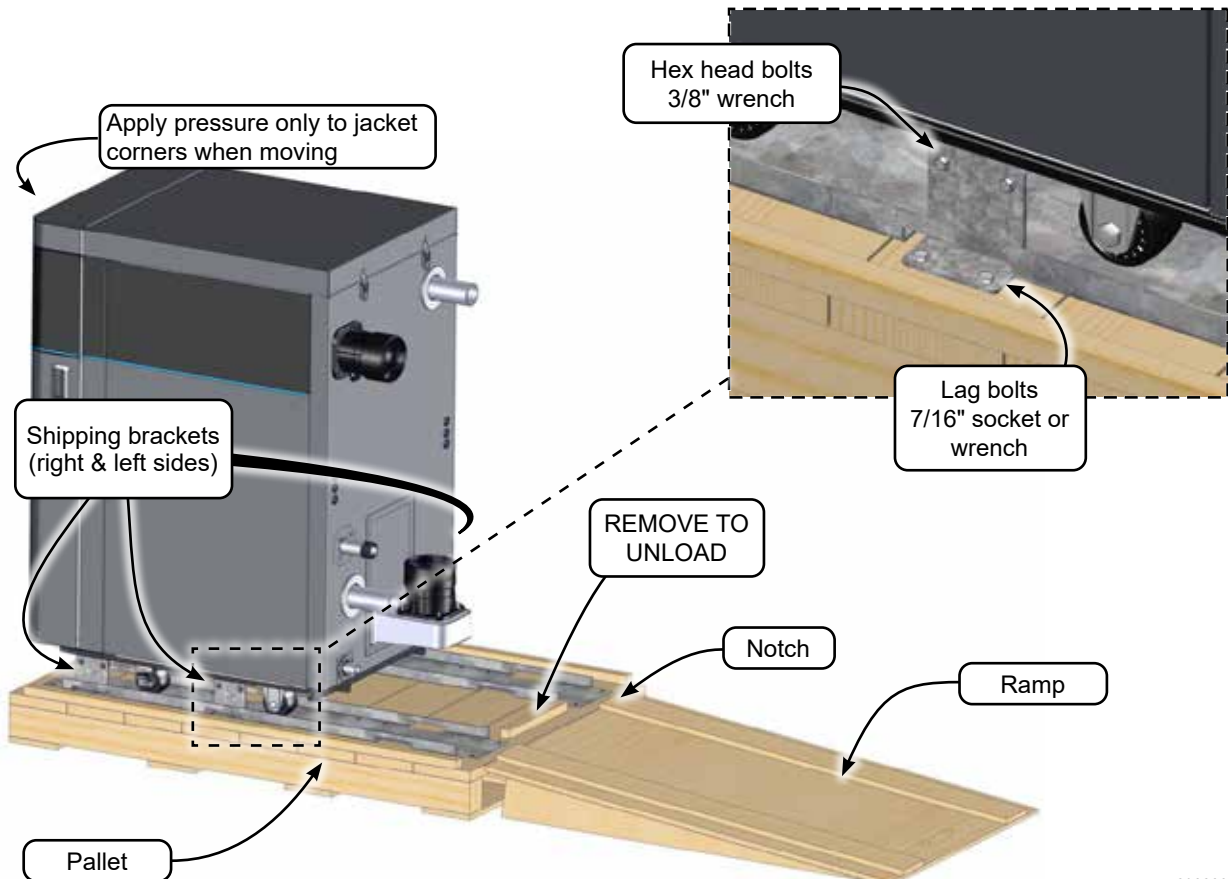

230008

Placing the Boiler

1. Roll the boiler down the ramp and move the boiler into position. The boiler must be unloaded from the pallet onto a solid, level surface.

⚠ WARNING

*The boiler is heavy. Use caution when rolling down the ramp. When moving the boiler, apply pressure **ONLY** at the jacket corner posts or water manifolds. Handling the boiler improperly can result in severe personal injury, death, or substantial property damage.*

2. The front two casters are swivel type, while the back two casters are fixed. Take care to keep the boiler straight when rolling.
3. Adjust the leveling legs down until they are firmly in contact with the floor. Remove the jacket panels to access bolt heads and jam nuts for leveling the boiler.
4. Continue adjusting the legs until the bottom of the boiler base is 1/16" (1.6 mm) above the floor while keeping the boiler level. Check the level, front to back and side to side. Measure level on the cover plate. See Figure 4.

⚠ CAUTION

Do not rest the boiler on the casters. The casters are intended for moving the boiler into position only. The support legs must be extended to take the load off the boiler.

Bolting the Boiler to Mounting Blocks

For applications requiring bolting down of the boiler (such as earthquake zone requirements), use the leveling legs to position the boiler until the bottom of the boiler base is 1/16" (1.6 mm) above the floor. The four brackets used as seismic mounting brackets are also used as shipping brackets. Reattach these brackets with the eight screws and eight lag bolts once the boiler is in place. See [Figure 3, page 14](#) and [Figure 5](#) for details. Refer to the seismic calculations document for additional information.

⚠ WARNING

Follow all applicable codes and recognized engineering design practices to verify the final mounting will meet all seismic, structural, and other requirements. Failure to comply can result in severe personal injury, death, or substantial property damage.

Figure 4 Leveling legs warning



Figure 5 Seismic mounting brackets (provided by others)

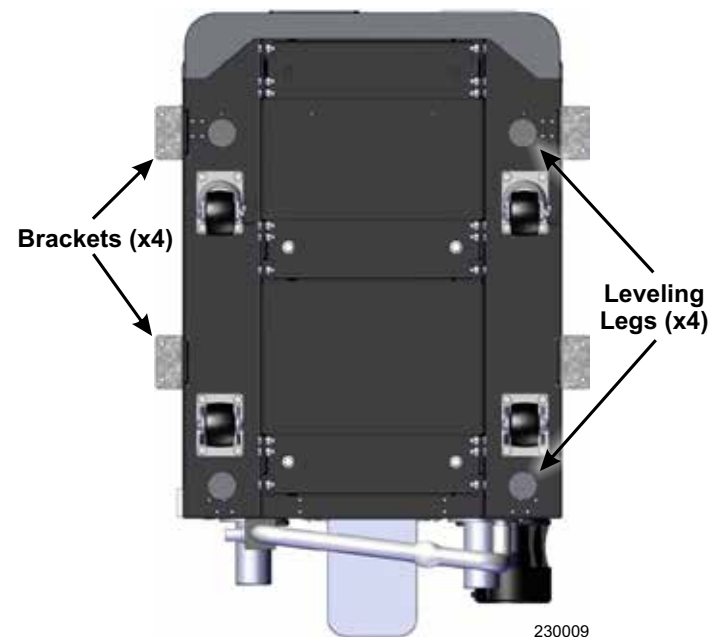

Prepare the Boiler, continued

Propane Conversion Procedure (when required)

All SVF boilers are shipped ready for natural gas operation. The boilers must be fitted with a propane orifice and propane venturi to be used with propane. A conversion kit to convert the boiler to propane is purchased separately (part number 384000423).

⚠ WARNING Turn off electrical supply to installed boilers before service. Close the external manual gas shut-off valve to isolate the boiler during conversion. Allow the boiler to cool if it has been operating. Failure to follow these instructions can result in severe personal injury, death, or substantial property damage.

1. Shut off power to the boiler before service.
2. Locate the propane orifice plate and the propane venturi from the conversion kit bag.
3. Verify that the stamping on the orifice plate is correct for the model size. There is one orifice for the SVF 500/600 boiler. The orifice size is 0.494".
4. Verify the orifice sizes on the propane venturi. The top orifice is 6.6 mm and the bottom orifice is 8.4 mm.
 - a. Ensure the label on the propane venturi reads:
 - VenturiØ: 45
 - InjØ: 840/660

⚠ WARNING The propane orifice size marking must match the required boiler orifice size. Incorrect sizing can cause leaking gas fumes, which can result in severe personal severe personal injury, death, or substantial property damage.

5. Make a coarse throttle adjustment to the gas valve.
 - a. Carefully open the throttle fully.
 - b. Close the throttle 4 and 7/8 turns.
6. Remove the two top panels from the boiler and set aside. Remove the side panels for easier access.
7. Using two 8 mm wrenches, remove the four bolts holding the silencer to the venturi.
8. Using two pipe wrenches, disconnect the gas flex line from the inlet pipe of the automatic gas valve.
9. Using an 8 mm wrench and 4 mm Allen wrench, remove the four bolts holding the gas pipe to the bottom of the venturi. A gasket will come free.

Figure 6 Propane orifice location

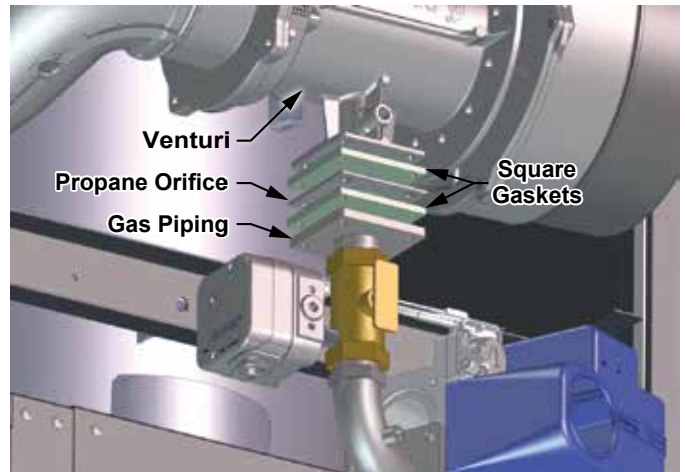

10. Remove the original (Natural Gas) venturi with O-ring from the blower with a 13 mm wrench. Discard the original (Natural Gas) venturi. Ensure the O-ring is in good condition. Replace if necessary.
11. Take the propane venturi from the kit and install it to the blower. Ensure that the gas hookup is in the down orientation, and the O-ring is seated properly between the blower and venturi. Use a 13 mm wrench to secure the three nuts to the studs that hold the venturi to the blower. These blower studs should be equally spread out at 120° intervals, at the 12, 4 and 8 o'clock positions. Tighten to 87 in-lbs (9.82 Nm).
12. Install the propane orifice plate between the gas pipe and the side port of the venturi, wedged between the two square gaskets supplied with the propane conversion kit. Secure the gas pipe to the venturi with an 8 mm wrench and a 4 mm Allen wrench and tighten to 44 in-lbs (5.0 Nm).
13. Install the silencer to the venturi. Secure the silencer with the four previously removed bolts using two 8 mm wrenches. Tighten to 44 in-lbs (5.0 Nm).
14. Reconnect the gas flex line to the inlet pipe of the automatic gas valve.
15. Apply the conversion label next to the rating label.
16. Reconnect the power to the boiler.

Test the boiler completely after conversion. Fill out the Fire Test label with the test results. Follow all instructions in this manual to start up the boiler. Check combustion levels and verify operation of the

boiler and all system components after conversion.

High Altitude Installations

For high altitude installations (over 2,000 ft.), maximum blower, minimum blower, and ignition RPM must be updated according to [Table 18, page 117](#).

If using propane as the input gas, target CO₂ values must also be adjusted according to the table. Make sure the boiler is converted to propane per the instructions on [page 16](#).

Pressure Test Preparation

Do not install the relief valve until pressure testing is complete. See [Relief Valve Installation on page 20](#) for installation instructions and warnings.

IMPORTANT

Apply pipe dope on all connections in the following steps. Use pipe dope sparingly.

Reference [Figure 7](#) for the following steps. All components in this section are provided by the installer except a 30 psig relief valve and the P/T gauge.

1. Remove the relief valve if it is installed.
2. On the boiler supply pipe, install two tees as shown in [Figure 7](#). Orient the tee closest to the boiler up into a vertical position. Install the second tee in a horizontal position.
 - a. The tee in the vertical position is where the relief valve will be installed after the pressure test. Install an NPT plug in this location for the pressure test.

Figure 7 Hydrostatic test piping connections - flanges, valves, and gaskets provided by installer



- b. The tee in the horizontal position is where the P/T gauge is installed for testing and for normal boiler operation.
3. Install a shut-off valve on the supply side and connect it to the rest of the system piping.
4. Install a drain valve and a shut-off valve on the boiler return pipe before connecting to the rest of the system piping. See [Figure 7](#) for the boiler drain location.
5. If the pressure test is conducted with a pressure over 160 psig, remove the automatic air vent located inside the boiler cabinet on the heat exchanger port; replace it with a 1/2" NPT plug.

Fill the Boiler

1. Open the shut-off valves installed on the supply and return connections.
2. Allow water to flow into the bottom connection and air to flow out the top connection.
3. When water reaches the shut-off valve on top, allow water to flow long enough to ensure all air is out of the heat exchanger.
4. Close the shut-off valves on supply and return lines.
5. Close off the water supply.

Prepare the Boiler, continued

Pressure Test Precautions

⚠ WARNING

Failure to comply with these precautions can result in severe personal injury, death, or substantial property damage.

All air MUST be purged out of the heat exchanger before performing the hydrostatic pressure test.

The test pressure MUST NOT exceed the maximum pressure on the P/T gauge. If the test pressure is going to exceed the maximum range of the current P/T gauge, use an appropriate gauge for the test.

Leaks must be repaired immediately. Leaks can damage the boiler, leading to substantial property damage.

DO NOT leave the boiler unattended at any time during testing. A cold water fill could expand and cause excessive pressure, resulting in severe personal injury, death, or substantial property damage.

The release of high pressure water should be done in a safe manner. Failure to release the water safely can result in severe personal injury, death, or substantial property damage.

DO NOT use petroleum-based cleaning or sealing compounds in the boiler system. Gaskets and seals in the system may be damaged, resulting in substantial property damage.

Perform Hydrostatic Pressure Test

1. Use the hand pump to raise water pressure for testing.
2. The test pressure should be 1.5 times the pressure setting of the relief valve.
3. Gradually apply pressure until test pressure is reached. Test pressures are shown in Table 4 and are compared to the normal operation of the boiler with the pressure relief valve installed.
4. Hold at test pressure for 10 minutes.
5. Maintain constant gauge pressure throughout the test.
6. Check for leaks. Repair any leaks from threaded joints. If leaks are found in the heat exchanger, consult your WM Technologies representative.
7. Slowly release pressure and drain.
8. Install the automatic air vent if removed.

Table 4 Test pressure

Relief Valve Pressure	Test Pressure
30 psig	45 psig
50 psig	75 psig
100 psig	150 psig
160 psig	240 psig

Install Water Piping

General Piping Information

NOTICE

Use two wrenches when tightening water piping at the boiler with one at the boiler interior piping to prevent it from turning. Failure to prevent boiler piping connections from turning could cause damage to boiler components.

Additional controls, when required:

The control module uses temperature sensors to provide both high limits protection and operating limit control. The module is UL353 Limit Controls certified to meet ASME CSD-1 and Section IV requirements. A manual reset of the equipped low water cut-off (LWCO) is performed through the control module. Some codes and jurisdictions may require additional external controls.

Operating limit set point =
Supply Max. Temperature + Off Differential

Additional limit controls:

- Consult local requirements for other codes and standards to determine if additional limit devices are needed.
- The control provides two sets of limit control contacts. One set will cause automatic reset, while the other will cause manual reset of the control. See the Field Wiring section starting on [page 66](#) for wiring information.
- The control can be reset using the manual RESET function on the control display.

NOTICE

If the heating system includes circuits that require lower temperature water along with circuits that require higher temperature water, it is recommended to protect low-temperature circuits with limit controls that are wired to a manual or automatic reset circuit on the control.

Figure 8 LWCO test button location

230126

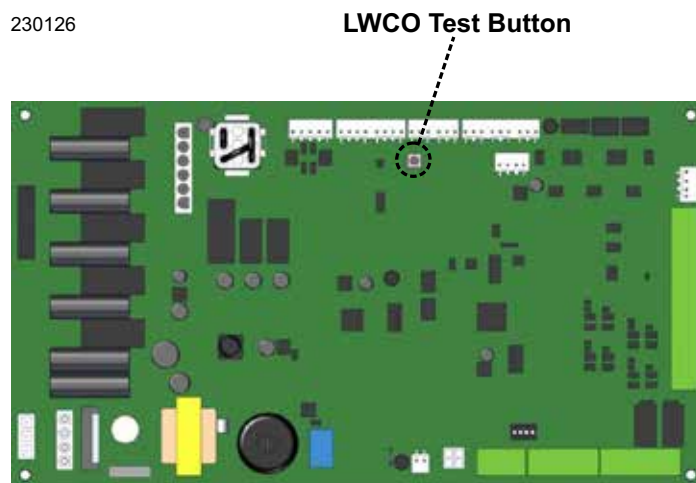

Low water cut-off:

A push-to-test LWCO is factory installed on the switch panel on the left side of the control tray. See Figure 8.

The LWCO probe is mounted on the front of the heat exchanger.

The LWCO is manually reset through the main control. This can be performed through the display by selecting <Reset Lockout>.

Backflow preventer:

Use a backflow check valve in the water fill as required by local codes.

Pressure and Temperature Gauge

The boiler is shipped with a 1/4" NPT pressure and temperature (P/T) gauge. The gauge has a pressure range up to 75 psig. This gauge meets ASME requirements for a relief valve setting of up to 50 psig.

The P/T gauge is mounted in a horizontal tee on the boiler supply outlet pipe. Installer must supply a tee connected to the system supply that has the correct sizing for the necessary P/T gauge. See [Figure 7, page 17](#) for placement details.

Install Water Piping, continued

Relief Valve Installation

⚠ WARNING

Do NOT install a relief valve with a pressure higher than 160 psig. This is the maximum allowable relief valve setting for the SVF boiler. The boiler is shipped with a 30 psig relief valve. Failure to comply can result in severe personal injury, death, or substantial property damage.

⚠ WARNING

Improper installation of the relief valve and discharge line can cause water damage and scalding. Follow all instructions and guidelines below and in this manual. Failure to comply can result in severe personal injury, death, or substantial property damage.

1. A 30 psig relief valve is shipped with the boiler. The valve must be installed by a qualified installer. The valve should be connected as close to the boiler water outlet as possible.
 2. Connect discharge piping to a safe disposal location according to the guidelines below.
- Discharge line must be connected to the relief valve outlet and run to a safe place of disposal. Terminate the discharge line in a manner that will prevent the possibility of severe burns or property damage should the valve discharge.
 - Discharge line must be as short as possible and be the same diameter as the valve discharge connection throughout its entire length.
 - Discharge line must pitch downward from the valve and terminate at least 6" above the floor drain where any discharge will be clearly visible.

Figure 9 Relief Valve Installed

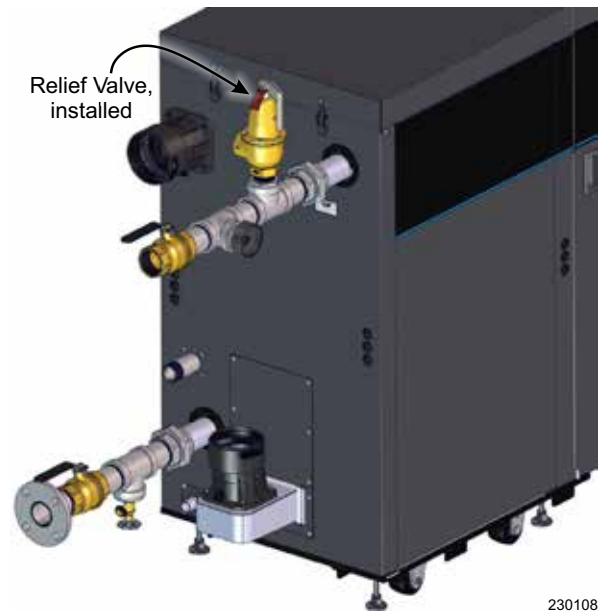

230108

- Discharge line shall terminate plain, not threaded, with a material serviceable for temperatures of 375°F (191°C) or greater.
- Do not pipe the discharge to any place where freezing could occur.
- Do not install any shut-off valve between the relief valve and boiler, or in the discharge line. Do not plug or place any obstruction in the discharge line.
- After filling and pressurizing the system, test the operation of the valve by lifting the lever. Make sure the valve discharges freely. If the valve fails to operate correctly, replace it with a new relief valve.

Pipe Sizing

Size the piping and the pumps to provide the required temperature rise. See Figure 10 for boiler head loss curves. See Table 5 for maximum and minimum flow rate through the boiler and head loss versus flow rate.

NOTICE

Pipe sizing should be based on the desired temperature rise for the system, corresponding to the recommended maximum flow rate. Failure to follow these guidelines can result in system issues.

NOTICE

DO NOT design the piping and components for a boiler flow rate above or below the ranges given in Table 5 without using one of the piping strategies listed below. Insufficient flow will cause nuisance outages due to limit operation. Excessive flow can damage the boiler heat exchanger from erosion.

Size system piping per Table 6, or apply recognized engineering practices to size the piping.

IMPORTANT

The SVF 500 and 600 boilers have 2" NPT male connections. Installer to provide reducers to adapt from external piping to the boiler supply and return connections if the system allows.

Higher flow rates than shown in Table 5:

- Use Primary/Secondary piping. See pages 24, 26, and 27.
- Add a differential pressure bypass valve to bypass the excessive flow in a Variable/Primary flow system, or provide an alternative engineering solution. See the figures on page 25.

Lower flow rates than shown in Table 5:

- Use Primary/Secondary piping.
- In a Variable/Primary flow system, it is recommended to install a flow switch that is set at the minimum flow rate of the boiler. The variable circulator will increase water flow and prevent the boiler from firing with an insufficient flow rate. The higher water flow will make the flow switch contact, which will start the boiler.

Figure 10 Pressure drop versus flow rate for SVF boilers

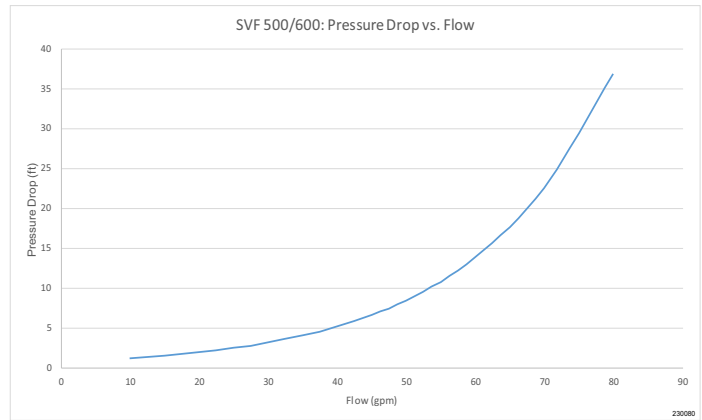

Table 5 Flow rate and pressure drop data

SVF 500			
Minimum Water Pressure	GPM	100% Rate Temp Rise (°F)	Boiler Head Loss (Feet w.c.)
10 PSI	48	20	7.5
	38	25	4.7
	32	30*	3.5
	27	35	2.8
	24	40***	2.3
	21**	45***	2.1
SVF 600			
Minimum Water Pressure	GPM	100% Rate Temp Rise (°F)	Boiler Head Loss (Feet w.c.)
10 PSI	57	20	11.9
	46	25	6.8
	38	30*	4.7
	33	35	3.6
	29	40***	3.0
	25**	45***	2.5

* Suggest design flow rate (30°F temp, rise, water only)
 ** Minimum Flow Rates (GPM):
 SVF 500: High Fire = 21, Low Fire = 4
 SVF 600: High Fire = 25, Low Fire = 4
 ***Temp Rises above 35°F are not recommended in high temp. systems; larger Boiler Out on/off Diff's maybe required for proper operation
 Notice: Boilers are designed to reduce firing rate when differential temperature reaches 50°F. When using boiler in a modulating flow, the minimum allowable water flow rate during low fire operation is 4 GPM. The variable speed pump must control flow between minimum and full rate in accordance with firing rate. See Faults and Action Items in boiler Manual, page 124.

Table 6 Recommended pipe sizing per flow rate

Sch 40 Pipe Diameter	Maximum Flow Rate GPM	SCH 40 Pipe Diameter	Maximum Flow Rate GPM
2	45	5	500
3	140	6	800
4	290	8	1650

Install Water Piping, continued

Expansion Tank and Make-up Water

Ensure the expansion tank size will handle boiler and system water volume and temperature. See [Table 27, page 142](#) for boiler water content.

The expansion tank must be located as shown in this manual or per recognized design methods. See the tank manufacturer's instructions for details.

NOTICE

Undersized expansion tanks cause system water loss from the relief valve, and make-up water to be added through the fill valve. Boiler failure can eventually result due to the excessive addition of make-up water.

Connect the expansion tank to the air separator only if the separator is on the suction side of the pump. Always install the system fill connection at the same point as the expansion tank connection to the system.

Most piping drawings in this manual show diaphragm expansion tanks. See Figure 12 for piping from the air separator to the expansion tank and make-up water line using a closed-type expansion tank.

Most chilled water systems are piped using a closed-type tank. Refer to [Figure 19, page 27](#).

Diaphragm or Bladder Expansion Tank

Always install an automatic air vent on top of the air separator to remove residual air from a system with a diaphragm or bladder expansion tank. See Figure 11.

NOTICE

When the boiler is installed above the system main piping using diaphragm or bladder tanks, install an automatic air vent in the top of the outgoing boiler piping to prevent air pocketing.

NOTICE

The expansion tank needs to be charged to the required system fill pressure before being connected to the system.

Figure 11 Expansion tank piping - diaphragm-type tank

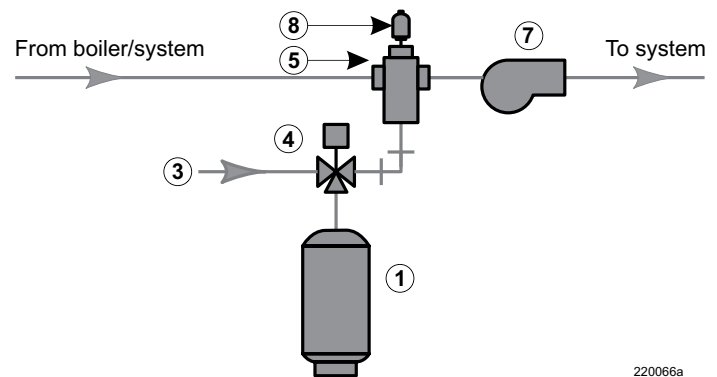
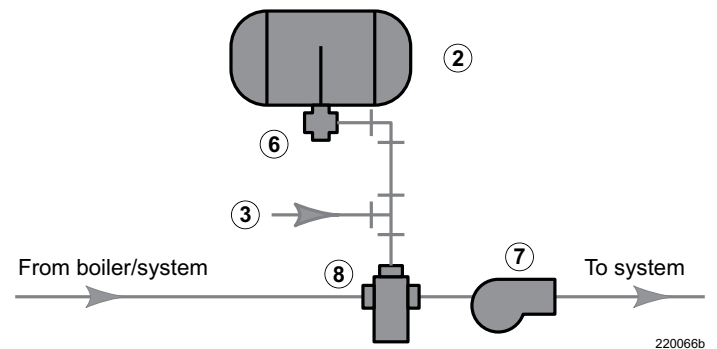

Figure 12 Expansion tank piping - closed-type tank



Legend – Figure 11 & Figure 12	
1. Diaphragm -type expansion tank	5. Air separator
2. Closed-Type expansion tank	6. Tank fitting
3. Make-up water line	7. System pump (when used)
4. Fill valve, typical	8. Automatic air vent

Closed-Type Expansion Tank

Refer to Figure 12 for piping connections when using a closed-type expansion tank.

Pitch any horizontal piping up towards the tank. Pitch at 1" per 5 ft. of piping. Connect to the tank with at least 3/4" piping to allow room for air to rise.

NOTICE

DO NOT use automatic air vents on closed-type expansion tank systems. If there is an automatic air vent installed on the heat exchanger, remove it before operation. Air must remain in the system and return to the tank to provide its air cushion. An automatic air vent would cause air to leave system, resulting in water-logging the expansion tank.

ZONE VALVE Zoning - General

The information on this page applies to all zone valve zoning applications.

NOTICE

Use at least the minimum pipe size shown in [Table 6](#), [page 21](#) on all boiler loop piping connecting the boiler to and from the primary/secondary connection (item 21 on the following pages). The primary/secondary piping shown on [pages 24, 26](#), and [27](#) ensures the boiler loop will have sufficient flow.

Expansion tank required:

- Provide a system expansion tank following the guidelines on [page 22](#).
- DO NOT use a closed-type tank if connecting to a water heater that is equipped with an automatic vent.

Domestic hot water tank, if used:

- DHW direct connection: Pipe from the near-boiler piping to the DHW tank's boiler connections as shown in this manual.
- DHW as zone: A DHW tank can be connected as a zone if a DHW tank is NOT already connected to the boiler. See the Advanced Manual to change TARGET MODULATION SENSOR to System Supply when system sensors are installed.
- DHW priority operation: Using Priority 1 for DHW (default) will turn off lower priorities during DHW calls. The MAX ON TIME setting can be adjusted to limit how long this occurs. Use Priority 2 or 3 for DHW if DHW priority is not desired.

Controlling the circulators:

- The control can control up to five circulators. Refer to the Field Wiring section starting on [page 66](#) for instructions on wiring to circulators.
- The factory default settings are not configured. Each input correlates to its respective circulator output. See the field wiring instructions, beginning on [page 66](#).
- For more than four zones, use an external zone controller.

IMPORTANT

Connect zone valve end switches to a space heating priority input to use default settings. Connect the system circulator to the corresponding output.

CAUTION

Use isolation relays if connecting 3-wire zone valve end switches to the inputs.

Install Water Piping, continued

ZONE VALVE Zoning - Primary/Secondary

IMPORTANT

Refer to [page 23](#) for general zone valve zoning information for all applications before installation.

This configuration is for zone valve systems using a boiler loop connected as a secondary circuit off a primary system loop. The primary/secondary piping shown in Figure 13 ensures the boiler loop will have sufficient flow. This piping also avoids applying the high head of the boiler circulator to the zone valves.

Install a system circulator (supplied by installer) capable of delivering the proper flow and head as shown.

The flow/check valve shown on the boiler outlet piping prevents gravity circulation in the boiler loop during DHW heating.

For other piping methods, see guidelines starting on [page 21](#).

ZONE VALVE Zoning - High-flow-rate or High-head-loss DHW Circuits

This configuration is for applications requiring DHW circuit flow rates higher than allowable for the boiler, or for high pressure drop coil-type DHW tanks.

Connect the piping as shown in Figure 14. The DHW water only flows through the secondary circuit connection piping. The primary/secondary piping shown ensures the boiler loop will have sufficient flow, and avoids applying the high head of the boiler circulator to the zone valves.

Size the connection piping (item 23) to handle the total flow it must handle.

Install a system circulator (supplied by installer) capable of delivering the proper flow and head.

The flow/check valve shown on the boiler outlet piping prevents gravity circulation in the boiler loop during DHW heating.

Figure 13 Zone valve zoning with optional DHW piping

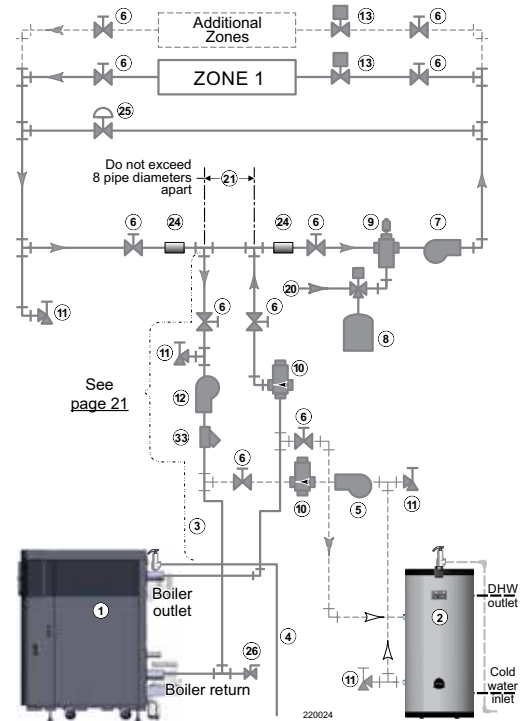
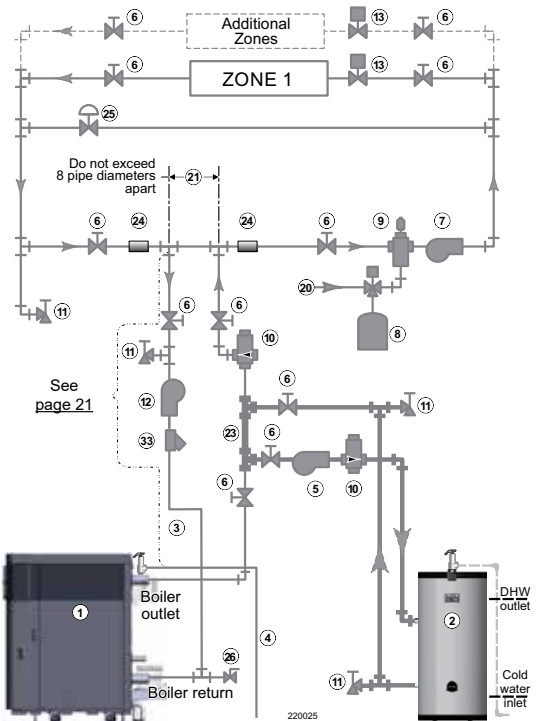

Figure 14 Zone valve zoning alternate with DHW piping



Legend – Figure 13 and Figure 14

- | | | |
|---|--|---|
| 1. SVF boiler | 9. Air separator | 23. DHW secondary connector piping; no more than eight pipe diameters apart |
| 2. Indirect water heater (DHW), if used | 10. Flow/check valves | 24. System supply and return immersion sensors; at least six pipe diameters (but no more than 3 ft.) from boiler connection tees. |
| 3. Boiler relief valve | 11. Purge/drain valves | 25. Bypass pressure regulator; for use in systems using high-head pumps that require a regulator to prevent damage to control valves. |
| 4. Relief valve discharge piping | 12. Boiler circulator | 26. External drain/blowdown valve, when used |
| 5. DHW circulator | 13. Zone valves, typical | 33. Strainer, recommended |
| 6. Isolation valves | 20. Make-up water supply | |
| 7. System circulator | 21. Primary/secondary connection; tees no more than eight pipe diameters apart | |
| 8. Diaphragm or bladder type expansion tank | | |

ZONE VALVE Zoning - Variable Primary Flow

IMPORTANT

Refer to [page 23](#) for general zone valve zoning information for all applications before installation.

This configuration is for applications that use a variable flow system pump. Figure 15 shows the variable primary flow with DHW as zone. Figure 16 shows the variable primary flow with optional DHW piping.

Install a system circulator (supplied by installer) capable of delivering the necessary variable flow and head as shown on this page.

The flow/check valve shown on the boiler outlet in Figure 16 prevents gravity circulation in the boiler loop during DHW heating.

An optional bypass with a differential pressure valve or pressure reducing valve may be used between the near boiler supply and return piping in high flow systems. If the bypass is used, ensure the system supply temperature sensor is placed *after* the bypass.

A flow switch is recommended if system flow could drop below the minimum flow specified in [Table 5, page 21](#). Installer must provide a tee for the flow switch and attach it to the boiler return pipe.

Figure 15 Variable primary flow, DHW as zone

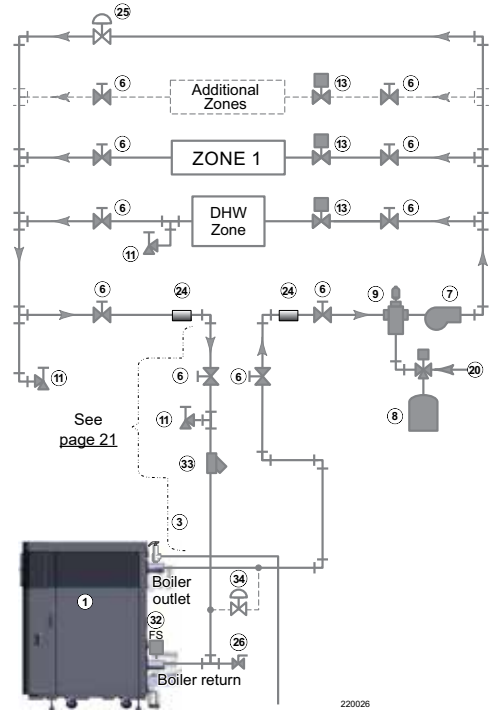
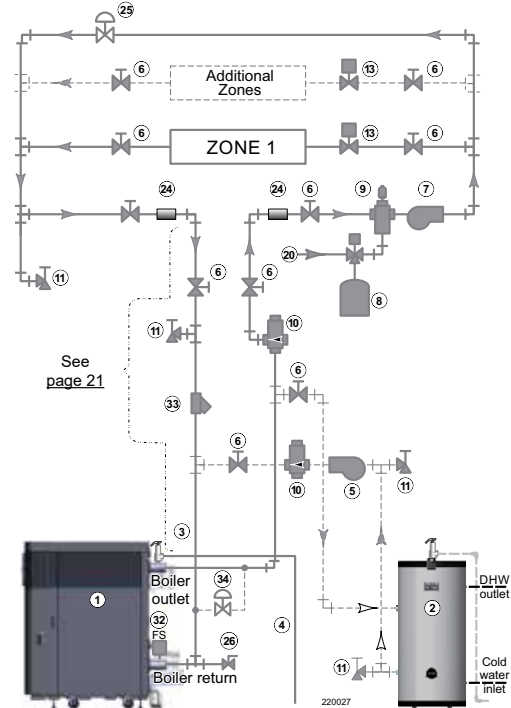

Figure 16 Variable primary flow, optional DHW piping



Legend – Figure 15 and Figure 16

1. SVF boiler	11. Purge/drain valves	25. Bypass pressure regulator; for use in systems using high-head pumps that require a regulator to prevent damage to control valves.
2. Indirect water heater (DHW), if used	12. Boiler circulator	26. External drain/blowdown valve, when used
3. Boiler relief valve	13. Zone valves, typical	32. Flow switch, by others
4. Relief valve discharge piping	20. Make-up water supply	33. Strainer, recommended
5. DHW circulator	21. Primary/secondary connection; tees no more than eight pipe diameters apart	34. Bypass pressure regulator or pressure reducing valve; for use in high flow systems to prevent excessive flow in the heat exchanger.
6. Isolation valves	23. DHW secondary connector piping; no more than eight pipe diameters apart	
7. System circulator	24. System supply and return immersion sensors; at least six pipe diameters (but no more than 3 ft.) from connection tees.	
8. Diaphragm or bladder type expansion tank		
9. Air separator		
10. Flow/check valves		

Install Water Piping, continued

ZONE VALVE Zoning - Circulator Zoning, Primary/Secondary

IMPORTANT

Refer to [page 23](#) for general zone valve zoning information for all applications before installation.

This configuration is for circulator-zoned systems using a boiler loop connected as a secondary circuit off a primary system loop.

Install a separate circulator (supplied by installer) for each zone capable of delivering the proper flow and head as shown in Figure 17.

The flow/check valve shown on the boiler outlet piping prevents gravity circulation in the boiler loop during DHW heating.

ZONE VALVE Zoning - Radiant Heating, Primary/Secondary

The SVF boiler is ideal for use in radiant heating. The unique heat exchanger design allows the boiler to work well even in condensing mode. There is no need to regulate boiler return water temperature in radiant heating applications.

The primary/secondary piping shown in Figure 18 ensures the boiler loop will have sufficient flow. The piping also avoids applying the high head of the boiler circulator to the zone valves. Apply this configuration for typical radiant heating applications.

Size the system piping and circulators to provide the flow and pressure drop needed. The flow/check valve shown on the boiler outlet piping prevents gravity circulation in the boiler loop during DHW heating.

Figure 17 Circulator zoning with optional DHW piping

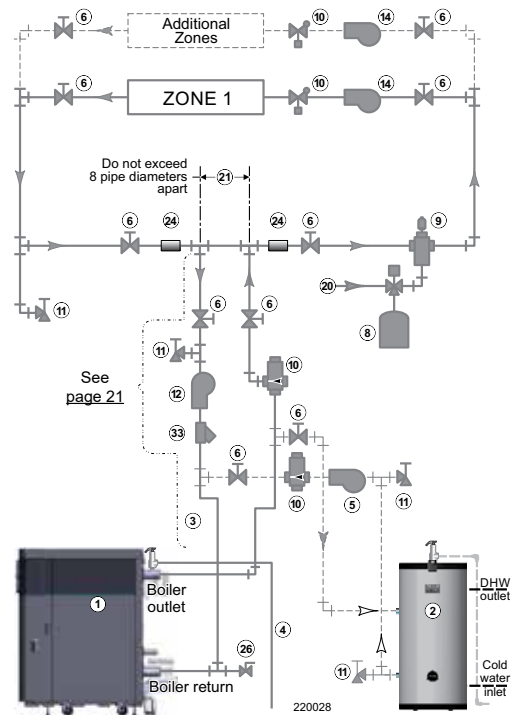
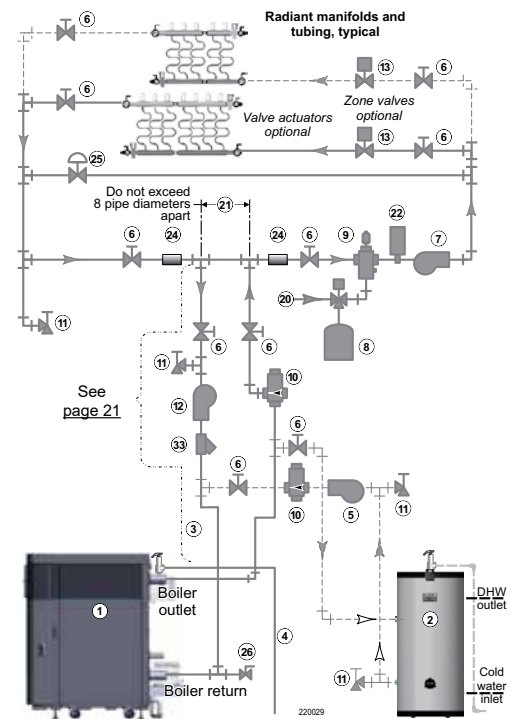

Figure 18 Radiant heating system with optional DHW



Legend – Figure 17 and Figure 18

1. SVF boiler	11. Purge/drain valves	24. System supply and return immersion sensors; at least six pipe diameters (but no more than 3 ft.) from boiler connection tees.
2. Indirect water heater (DHW), if used	12. Boiler circulator	25. Bypass pressure regulator; for use in systems using high-head pumps that require a regulator to prevent damage to control valves.
3. Boiler relief valve	13. Zone valves, typical	26. External drain/blowdown valve, when used
4. Relief valve discharge piping	14. Zone pumps, typical	33. Strainer, recommended
5. DHW circulator	20. Make-up water supply	
6. Isolation valves	21. Primary/secondary connection; tees no more than eight pipe diameters apart	
7. System circulator	22. Optional high limit temperature control; set to protect radiant heating	
8. Diaphragm or bladder type expansion tank		
9. Air separator		
10. Flow/check valves		

ZONE VALVE Zoning - Water Chiller Systems, Primary/Secondary

IMPORTANT

Refer to [page 23](#) for general zone valve zoning information for all applications before installation.

This configuration is for applications using a chilled water system. The chiller must be piped in parallel with the boiler. Use appropriate valves to prevent chilled medium from entering the boiler.

The space heating system can be zones with circulators if a separate circulator is supplied for the chilled water loop. Install a separate circulator for each zone.

The flow/check valve shown on the boiler outlet piping prevents gravity circulation in the boiler loop during DHW heating.

Chilled medium, if used, is piped in parallel with heating boiler as shown in Figure 19. Use appropriate valves to prevent chilled medium from entering the boiler.

NOTICE

If the boiler is connected to heating coils located in air handling units where they can be exposed to refrigerated air, use flow control valves or other automatic means to prevent gravity circulation during cooling cycle.

NOTICE

If antifreeze is used in the system, consider the effects of antifreeze on circulator sizing and DHW performance. Some local codes may require double-wall DHW heat exchanger design. Use only the antifreeze listed on [page 131](#) for use with this boiler.

Figure 19 Chilled water system with optional DHW piping

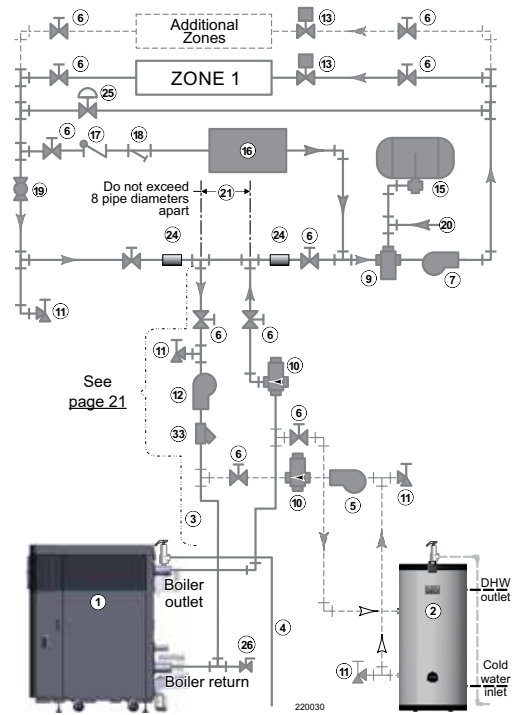

Legend – Figure 19

1. SVF boiler	12. Boiler circulator	21. Primary/secondary connection; tees no more than eight pipe diameters apart
2. Indirect water heater (DHW), if used	13. Zone valves, typical	24. System supply and return immersion sensors; at least six pipe diameters (but no more than 3 ft.) from boiler connection tees.
3. Boiler relief valve	15. Closed-type expansion tank	25. Bypass pressure regulator; for use in systems using high-head pumps that require a regulator to prevent damage to control valves.
4. Relief valve discharge piping	16. Water chiller	26. External drain/blowdown valve, when used
5. DHW circulator	17. Check valve	33. Strainer, recommended
6. Isolation valves	18. Strainer	
7. System circulator	19. Balancing valve	
9. Air separator	20. Make-up water supply	
10. Flow/check valves	21. Primary/secondary connection; tees no more than eight pipe diameters apart	
11. Purge/drain valves		

Commonwealth of Massachusetts Installations

Commonwealth of Massachusetts — When the boiler is installed within the Commonwealth of Massachusetts, the boiler must be installed by a licensed plumber or gas fitter. Read and comply with the instructions below.

1. **REQUIREMENTS:** For all sidewall horizontally-vented gas-fueled equipment installed in every dwelling, building or structure used in whole or in part for residential purposes, including those owned or operated by the Commonwealth and where the side wall exhaust vent termination is less than 7 feet above finished grade in the area of the venting, including but not limited to decks and porches, the following requirements shall be satisfied:
 - a. **INSTALLATION OF CARBON MONOXIDE DETECTORS.**
At the time of installation of the side wall horizontal vented gas fueled equipment, the installing plumber or gas fitter shall observe that a hard wired carbon monoxide detector with an alarm and battery back-up is installed on the floor level where the gas equipment is to be installed. In addition, the installing plumber or gas fitter shall observe that a battery operated or hard wired carbon monoxide detector with an alarm is installed on each additional level of the dwelling, building or structure served by the side wall horizontal vented gas fueled equipment. It shall be the responsibility of the property owner to secure the services of qualified licensed professionals for the installation of hard wired carbon monoxide detectors.
 - In the event that the side wall horizontally vented gas fueled equipment is installed in a crawl space or an attic, the hard wired carbon monoxide detector with alarm and battery back-up may be installed on the next adjacent floor level.
 - In the event that the requirements of this subdivision can not be met at the time of completion of installation, the owner shall have a period of thirty (30) days to comply with the above requirements; provided, however, that during said thirty (30) day period, a battery operated carbon monoxide detector with an alarm shall be installed.
 - b. **APPROVED CARBON MONOXIDE DETECTORS.** Each carbon monoxide detector as required in accordance with the above provisions shall comply with NFPA 720 and be ANSI/UL 2034 listed and IAS certified.
 - c. **SIGNAGE.** A metal or plastic identification plate shall be permanently mounted to the exterior of the building at a minimum height of 8 feet above grade directly in line with the exhaust vent terminal for the horizontally vented gas fueled heating appliance or equipment. The sign shall read, in print size no less than one-half (1/2) inch in size, "GAS VENT DIRECTLY BELOW. KEEP CLEAR OF ALL OBSTRUCTIONS."
 - d. **INSPECTION.** The state or local gas inspector of the side wall horizontally vented gas fueled equipment shall not approve the installation unless, upon inspection, the inspector observes carbon monoxide detectors and signage installed in accordance with the provisions of 248 CMR 5.08(2)(a) 1 through 4.
2. **EXEMPTIONS:** The following equipment is exempt from 248 CMR 5.08(2)(a)1 through 4:
 - a. The equipment listed in Chapter 10 entitled "Equipment Not Required To Be Vented" in the most current edition of NFPA 54 as adopted by the Board; and
 - b. Product Approved side wall horizontally vented gas fueled equipment installed in a room or structure separate from the dwelling, building or structure used in whole or in part for residential purposes.
3. **MANUFACTURER REQUIREMENTS — GAS EQUIPMENT VENTING SYSTEM PROVIDED.**
When the manufacturer of Product Approved side wall horizontally vented gas equipment provides a venting system design or venting system components with the equipment, the instructions provided by the manufacturer for installation of the equipment and the venting system shall include:
 - a. Detailed instructions for the installation of the venting system design or the venting system components; and
 - b. A complete parts list for the venting system design or venting system.
4. **MANUFACTURER REQUIREMENTS — GAS EQUIPMENT VENTING SYSTEM NOT PROVIDED.**
When the manufacturer of a Product Approved side wall horizontally vented gas fueled equipment does not provide the parts for venting the flue gases, but identifies "special venting systems", the following requirements shall be satisfied by the manufacturer:
 - a. The referenced "special venting system" instructions shall be included with the appliance or equipment installation instructions; and
 - b. The "special venting systems" shall be Product Approved by the Board, and the instructions for that system shall include a parts list and detailed installation instructions.
5. **PLASTIC VENTING SYSTEMS.**
The only plastic piping which may be used for venting appliances shall be:
 - a. Allowed by the appliance manufacturer.
 - b. Listed to a national/international standard for plastic venting systems.
 - c. Product-accepted for that purpose by the board.
6. **INSTALLATION INSTRUCTIONS.**
A copy of all installation instructions for all Product Approved side wall horizontally vented gas fueled equipment, all venting instructions, all parts lists for venting instructions, and/or all venting design instructions shall remain with the appliance or equipment at the completion of the installation.

Venting and Combustion Air — General

Code Compliance

Venting and combustion air piping installations must provide provisions in accordance with “Air for Combustion and Ventilation,” of the National Fuel Gas Code – ANSI Z223.1/NFPA 54, latest edition, or sections 8.2-8.4 of the Natural Gas and Propane Installation Code – CAN/CSA B149.1, and applicable local building codes.

⚠ DANGER

DO NOT common vent boilers with other boilers or appliances. Each boiler must have its own vent. Inspect finished vent and air piping thoroughly to ensure all are airtight and comply with instructions in this manual and applicable codes. Verify that all air openings are correctly sized, unobstructed, and free of airborne contaminants. Failure to provide a properly installed vent and air system will result in severe personal injury or death.

⚠ WARNING

Do not cover nonmetallic vent pipe with thermal insulation. Failure to comply can result in severe personal injury, death, or substantial property damage.

⚠ WARNING

Provide a vent manufacturer’s bird screen at each termination. Purchase bird screens from the vent or air piping supplier. Failure to comply can result in severe personal injury, death, or substantial property damage.

⚠ WARNING

Use sweep elbows for all vent and air piping. DO NOT use short-radius elbows for vent or air piping. Failure to comply can result in severe personal injury, death, or substantial property damage.

Venting Methods

There are two venting methods available. Follow the instructions on the following pages for the method used.

Method 1: Direct Exhaust

Combustion air is taken from the inside. Air piping is not connected to the air inlet.

Combustion air must be supplied through openings into the boiler room. Follow the instructions in this manual and comply with all applicable codes. Combustion air must not be exposed to any of the contaminants listed in [Table 7, page 30](#). Ensure the air and boiler will not contain contaminated air.

Where the SVF boiler shares a space with other appliances, the combustion air openings must be sized to handle the combined requirements of all appliances in the space.

Method 2: Direct Vent

Combustion air is piped to the boiler from the outside. Follow the instructions in this manual and comply with all applicable codes. Ensure the air inlet is not likely to draw in contaminated air. Do not terminate air piping in locations that can allow contamination of combustion air. Refer to [Table 7, page 30](#) for a list of contaminants and sources.

Combustion air can be piped individually for each boiler, or it can be manifolded as shown in [Figure 25, page 40](#). Combustion and ventilation openings may also be required in boiler room walls per instructions in this manual and applicable codes.

Vent and Air Piping

Use only the materials listed in this manual for vent and air pipe and fittings. Refer to [page 33](#) for information and hazards. See [Figure 22, page 36](#) for maximum lengths and reductions required for fittings.

Boiler Categories

The SVF boilers are approved for Category II and Category IV ratings. The following pages of this manual will specify which category applies to the venting information given.

Category II: The boiler is setup with a negative pressure vent and is likely to condense in the vent. This category requires a direct exhaust venting method.

Category IV: The boiler is setup with a positive pressure vent and is likely to condense in the vent. This category can use either direct exhaust or direct vent methods.

Venting and Combustion Air — General, continued

Using a Chimney

⚠WARNING

A chimney must only be used as a chase for vent and air piping and must meet all requirements as listed below. Failure to comply can result in severe personal injury, death, or substantial property damage.

A masonry chimney can only be used as a pipe chase for vent and air pipes. No other appliance or fireplace can be connected to the chimney.

- The vent and air piping must be installed as instructed in this manual. All joints must be sealed.
- The chimney must be straight with no offsets. The vent and air piping materials must comply with this instruction manual.
- The chimney must be fitted with a sealed access opening through which the interior of the chimney can be inspected.
- The chimney and liner must be inspected at least once annually.

Combustion Air Contamination

Provide combustion air openings or air inlet piping as described in this manual. See Table 7 for products and areas that may cause contaminated combustion air.

Table 7 Corrosive contaminants and sources

Products to avoid
Spray cans containing chloro/fluorocarbons
Permanent wave solutions
Chlorinated waxes and cleaners
Chlorine-based swimming pool chemicals
Calcium chloride used for thawing
Sodium chloride used for water softening
Refrigerant leaks
Paint or varnish removers
Hydrochloric acid and muriatic acid
Cements and glues
Anti-static fabric softeners used in clothes dryers
Chlorine-type bleaches, detergents, and cleaning solvents
Adhesives used to fasten building products and other similar products
Excessive dust and dirt

Areas likely to have contaminants
Laundry and dry cleaning areas and establishments
Swimming pools
Metal fabrication plants
Beauty shops
Refrigeration repair shops
Photo processing plants
Auto body shops
Plastic manufacturing plants
Furniture refinishing areas and establishments
New building construction
Remodeling areas
Garages with workshops

Vent and Air Adapters

Vent connections are sized for DuraVent Fas-N-Seal®, DuraVent PolyPro®, PVC, and CPVC venting. Installers must provide the correct PVC/CPVC adapters where necessary. See Table 8 for a list of adapters and part numbers.

PVC Piping

If using PVC for piping, CPVC pipe must be used on the first 10 linear ft. of the exhaust of a boiler. PVC can only be used after 10 linear ft. of CPVC. All fittings within the first 10 ft. must be CPVC. See Figure 20 for additional details.

⚠ WARNING

DO NOT use PVC on the first 10 ft. of boiler exhaust piping. Failure to comply can result in severe personal injury, death, or substantial property damage.

Table 8 Vent and air adapter part numbers

SVF Boiler Models 500/600			
Supplier / Manufacturer	Description	Mechanical Locking Collar	Vent Adapter Part Number
M&G Simpson-DuraVent PolyPro®	4" polypropylene pipe	810004128	No adapter required
M&G Simpson-DuraVent Fas-N-Seal®	4" AL29-4C SS	—	No adapter required
Heat Fab, Inc. Saf-T-Vent®	4" AL29-4C SS	—	9401PVC
Z-Flex, Inc. Z-Vent®	4" AL29-4C SS	—	2SVSPVC04
Centrotherm	4" InnoFlue	IADHC0404	ISAAL0404
Metal-Fab, Inc. CORR/GUARD	4" AL29-4C SS	—	4CGPVCA

Figure 20 PVC venting requirements

Exhaust ONLY after 10 linear ft., the pipe and fittings can then be transitioned from CPVC to PVC.

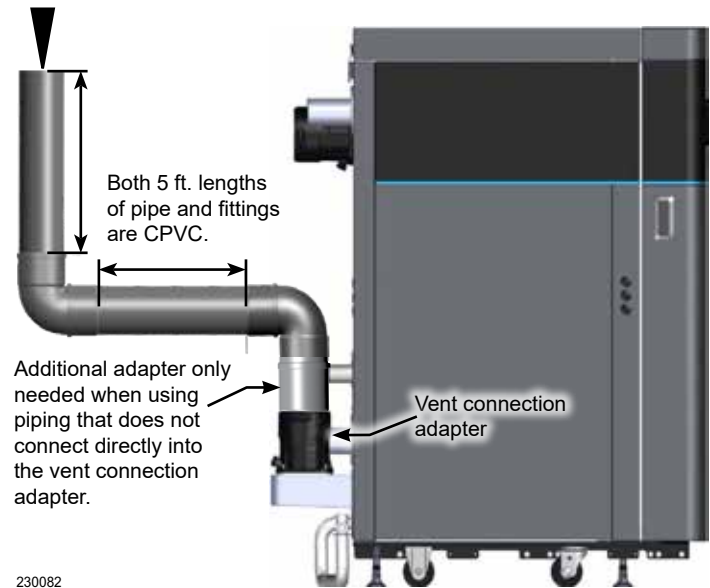

Venting and Combustion Air Options

Existing Vent System

⚠ DANGER

DO NOT install the SVF boiler into a common vent with any other appliance. This will cause flue gas spillage or appliance malfunction, resulting in severe personal injury, death, or substantial property damage.

⚠ WARNING

Follow all venting and piping instructions. Failure to follow all instructions can cause flue gas spillage and carbon monoxide emissions, which can result in severe personal injury or death.

When replacing an existing boiler with an SVF boiler, do not use the existing common vent. The SVF boiler requires its own vent and air piping as specified in this manual. If using a Category II system setup, see additional venting requirements on pages 34-35.

Removal of the previous boiler may cause an issue for the appliances that remain on the old common vent as the vent may be too large. The following test is intended to check for proper operation of the appliances remaining on the old common vent system.

Existing Vent System Test Procedure

Perform this test when removing a boiler from the common venting system. The following steps shall be followed with each appliance remaining connected to the common venting system. Test each appliance separately while in operation. Ensure all other appliances connected to the common vent are not in operation.

1. Seal any unused openings in the common venting system before proceeding with the test.
2. Visually inspect the venting system for proper size and horizontal pitch. Ensure there is no blockage, restriction, leakage, corrosion, or other deficiency that could cause an unsafe condition.
3. Close all building doors and windows as practical. Close all doors between the location of the appliances connected to the common venting system and other spaces of the building.

4. Turn on the clothes dryer and any other appliance not connected to the common venting system. Turn on all exhaust fans, except for a summer exhaust fan, and operate at maximum speed. Exhaust fans include range hoods and bathroom fans. Close fireplace dampers.
5. Place the appliance being inspected into operation. Follow the lighting instructions. Adjust the thermostat so the appliance will operate continuously.
6. Test for spillage at the draft hood relief opening after five minutes of main burner operation. Use the flame of a match or candle, or smoke from a cigarette, cigar, or pipe.
7. After it has been determined that each appliance remaining connected to the common venting system properly vents when tested as outlined here, return doors, windows, exhaust fans, fireplace dampers, and any other gas-burning appliance to their previous conditions of use.

Correct any improper operation of the common venting system so the installation conforms with the National Fuel Gas Code – ANSI Z223.1/NFPA 54, latest edition. Adhere to the National Gas and Propane Installation Code – CAN/CSA B149.1 for Canada.

When resizing any portion of the common venting system, approach the minimum size as determined using the appropriate tables in part 11 of the National Fuel Gas Code – ANSI Z223.1/NFPA 54, and Natural Gas and Propane Installation Code – CAN/CSA B149.1.

Vent and Air Piping Materials

Use only the materials listed in Table 9 for vent and air piping. Ensure that all materials used meet local codes. See [Table 8, page 31](#) for adapter part numbers.

Every PP vent and air piping joint must include a locking collar. See [Table 8, page 31](#) for required lock collar part numbers. DO NOT use alternative locking collars.

All PVC and CPVC joints should be permanently joined using the suitable primer and cement for the vent material.

⚠WARNING

DO NOT use cellular core PVC (ASTM F891), cellular core CPVC, Radel® (polyphenylsulfone) pipe, or any other material not listed in Table 9. Failure to comply can result in severe personal injury, death, or substantial property damage.

⚠WARNING

Failure to supply locking collars and seal the joints could cause vent and air piping leakage, which can result in severe personal injury, death, or substantial property damage.

⚠WARNING

DO NOT mix piping from different pipe manufacturers unless using adapters specifically designed for that purpose by the manufacturer. Failure to comply can result in severe personal injury, death, or substantial property damage.

⚠WARNING

DO NOT cover non-metallic vent pipe and fittings with thermal insulation. Failure to comply can result in severe personal injury, death, or substantial property damage.

Table 9 Vent and air piping materials

Items	Material	Supplier / Manufacturer	United States	Canada
Vent or air pipe fittings	Polypropylene	M&G Simpson-DuraVent - PolyPro	Certified for Category II & IV and direct vent appliance venting	Plastic vent pipe must be certified to ULC S636 if required by local codes
		Centrotherm Eco Systems - InnoFlue Single-wall -Requires adapter by others-		
	AL29-4C stainless steel	M&G Simpson-DuraVent - Fas-N-Seal	Certified for Category II & IV and direct vent appliance venting	Certified for Category II & IV and direct vent appliance venting
		Heat Fab, Inc. - Saf-T Vent -Requires adapter by others-		
		Metal-Fab, Inc. - Corr/Guard -Requires adapter by others-		
	PVC Schedule 40 See Vent and Air Adapters for additional requirements when using PVC on the exhaust.	Z-Flex, Inc. - Z-Vent -Requires adapter by others-	ANSI/ASTM D1785	Plastic vent pipe must be certified to ULC S636 if required by local jurisdiction. Air pipe can be any of those listed at left if acceptable by local codes.
PVC-DWV Schedule 40 See Vent and Air Adapters for additional requirements when using PVC on the exhaust.		ANSI/ASTM D2665		
CPVC Schedule 40		ANSI/ASTM F441		
Primer and Cement	PVC	ANSI/ASTM D2564 (cement) ANSI/ASTM F656 (primer)	ULC S636 rated Primers and Cements	
	CPVC	ANSI/ASTM F493 (cement) Primer that is approved for CPVC.		
	CPVC to PVC transition	Use only Primer and Cement suitable for joining CPVC and PVC pipe.		



Venting and Combustion Air Options, continued

Category II Requirements

In addition to the SVF boilers Category IV rating (positive pressure, likely to condense), SVF boilers are also approved for Category II (negative pressure, likely to condense).

The vent system for a Category II SVF boiler is considered a designed and engineered vent system. This system should be designed by a professional while using accepted engineering practices in accordance to local authority having jurisdiction. The Category II venting option requirements are as follows.

- Vertical vent termination only.
- Must not be installed into an existing common vent system with other appliances.
- Combustion air from the boiler room. See Direct Exhaust Combustion Air opening requirements in [Figure 23, page 38](#).
- The vent shall consist of a 3.5 ft. length piece of 4" diameter straight pipe directly after the vent or air adapter, and before any diameter or direction changes in the vent. After at least 3.5 ft. of piping, installer can use a bushing up to an 6" diameter. See [Figure 21](#) for an example. See [Table 10](#) for boiler-specific vent data.
- The vent system should be designed so that the pressure in the vertical vent pipe immediately following the boiler is between the ranges provided in [Table 10](#) during all operating conditions (e.g., High fire, Low Fire).
- Flue gas temperature should not exceed 210°F. The boiler will start to reduce the firing rate at a flue temperature of 200°F, and it will shut down once it exceeds 210°F. The flue gas temperature standard is within 20°F and 30°F of the return water temperature of the boiler. If there is the potential for a wide variation in return water temperatures, the lowest possible temperature should be used for any calculations.
- The Stack/Vent Flow Rate for each individual boiler model is listed in [Table 10](#). This flow rate is based on the unit running at 9% CO₂ and the maximum flue gas temperature of 200°F. The values can vary depending on the location of the installation and operating conditions.

Figure 21 Category II venting



Table 10 Rating and vent data

Boiler Model	Input	Stack/ Vent flow rate	Negative pressure maintained at vent connection of the boiler	Connection/ Minimum vent diameter required for Category II*
	Btuh	Scfm	Inches W.C.	
SVF 500	500,000	105	-0.001 to -0.100	6"
SVF 600	600,000	125	-0.001 to -0.100	6"

*The SVF boiler vent or air connection is sized for 4" DuraVent Fas-N-Seal, DuraVent PolyPro, PVC, and CPVC venting. Installer must provide the correct adapters or reducers needed to connect to other approved vent manufacturer's products. See [Table 8, page 31](#) for a list of adapters.

- A carbon monoxide detector is required in the boiler room for SVF boilers installed in a Category II configuration. The carbon monoxide detector must be wired in the same electrical circuit as the boiler. Check your local codes for any additional requirements of carbon monoxide detectors.

Category II Requirements, continued

⚠ WARNING

Install a Category II boiler system per all instructions in this manual. Improper Installation of a Category II vent system that results in positive pressure in the vent system can cause flue gas spillage and carbon monoxide, which can result in severe personal injury or death.

In applications where the venting system cannot maintain the required negative pressure on the boiler outlet via natural draft, WM Technologies recommends the use of a variable speed chimney fan or power venter to ensure that the appropriate negative pressure range is kept for Category II venting. Due to the higher efficiency of the SVF boiler, the exhaust gas temperatures are lower, resulting in less draft when using a chimney fan or power venter.

A flow proving switch should also be wired into the closure switch on the J18 terminal across ports 2 and 3 of the boiler. The use of this device should be considered in any engineered vent system in accordance to local authority having jurisdiction.

WM Technologies recommends the use of a double acting barometric damper or modulating damper to ensure the appropriate negative pressure range is kept for Category II venting. The use of this device should be considered in any engineered vent system in accordance to local authority having jurisdiction.

When using a damper of any kind, it is recommended to use a thermal spill switch to detect any exhaust flow into the boiler room. Verify the temperature range on the thermal spill switch is adequate for the flue gas temperature from the SVF boiler. The use and set-point of this shall be determined by the system engineer in accordance to local authority having jurisdiction.

Code Compliance:

Venting and combustion air piping installations must provide provisions for combustion and ventilation air in accordance with the section, "Venting of Equipment" of the National Fuel Gas Code – ANSI Z223.1/NFPA 54, latest edition, section "Venting Systems and Air Supply for Appliances" of the Natural Gas and Propane Installation Code – CAN/CSA B149.1, or applicable provisions of the local building codes.

⚠ WARNING

Follow all applicable national and local codes for installations. Failure to comply with the codes can result in severe personal injury, death, or substantial property damage.

Venting and Combustion Air Options, continued



Vent and Air Terminations for Category IV

The figure below lists the acceptable vent and air pipe terminations for Category IV as described in this manual.

The SVF boiler vent or air connection is sized for 4" DuraVent Fas-N-Seal, DuraVent PolyPro, PVC, and CPVC. The installer must provide the correct adapters/reducers needed to connect to other approved vent manufacturer's products.

The air inlet adapter is installed on the back of the boiler as shown in [Figure 81, page 133](#).

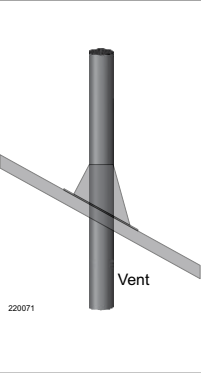
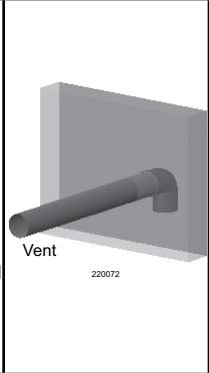
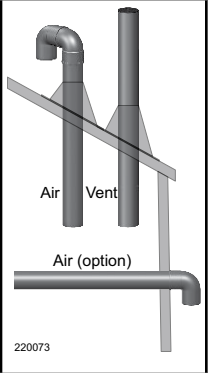
Figure 22 SVF boiler Category IV venting and air piping - options and piping limits

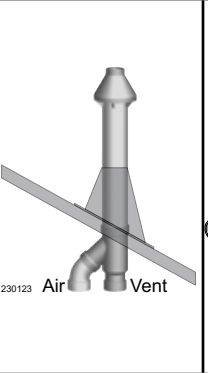
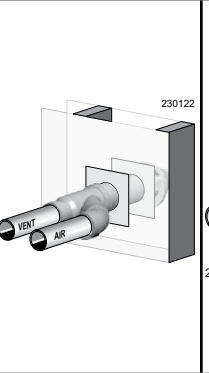
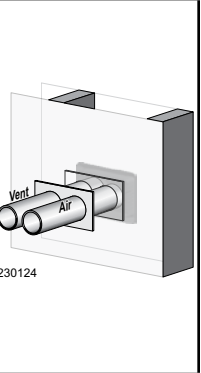
Use only the pipe materials listed in Table 9, page 33						
The information below is for SVF boiler models 500/600 with a 4" pipe size						
Vertical Direct Exhaust	Sidewall Direct Exhaust	Vertical Direct Vent (vertical or sidewall air)	Sidewall Direct Vent (vent and air out sidewall)	Vertical PVC or PP Concentric	Sidewall PVC Concentric	Sidewall PVC Vent and Air Plate
						
See page 41	See page 43	See page 46	See page 49	See page 52	See page 55	See page 58
Thickness of wall or roof vent penetration (all): Max: 18" Min: 0"						
Length, equivalent feet (all): Max: 100 ft. Min: 10 ft. (see information below)						
Note: For Category IV installations, ensure the flue venting system is designed to maintain a slightly positive exhaust pressure which MUST not exceed 1.9"W.C.						
NOTICE If the total number of elbows used in the vent and air piping and terminations is more than two elbows in the vent and one elbow in the air piping, reduce the maximum lengths above by the following lengths for each additional elbow (whether 45° or 90°). Boilers will derate as vent and air pipe length increases. See Table 28, page 142 for derate per piping length.						
SS	4" vent or air piping: See the manufacturer's recommendations for equivalent vent length per elbow.					
PP	• Centrotherm	• 4" - 87° elbow = 8'	• 4" - 45° elbow = 3'			
	• Duravent	• 4" - 90° elbow = 12'	• 4" - 45° elbow = 5'			
PVC	4" vent or air piping: Reduce the maximum allowable length by 7ft for each additional 90° elbow used and 5 ft for each additional 45° elbow used."					
NOTICE If the pipe manufacturer's equivalent lengths for elbows are longer than the values listed above, use the manufacturer's value for length reduction per elbow.						

Room Air Openings

Combustion Air Provision — Direct Exhaust

The SVF commercial boiler can use inside air if no contaminants are present in the boiler space. If contaminants are likely to be present, install the boiler as a direct vent appliance. Use the appropriate vent instructions in this manual.

The boiler room must be fitted with combustion air openings large enough to provide air for all appliances in the room. Use the following information to size the openings. Ensure the installation complies with all applicable codes and standards.

Combustion Air Provision — Direct Vent

For direct vent installations, combustion air must be ducted directly from outside to the boiler air inlet fitting. The boiler room will still require air openings for ventilation and for combustion air for other appliances.

Sizing Combustion Air Openings

Air openings provide ventilation to prevent overheating of the boiler controls and boiler space. Air is also needed for other appliances located in the same space.

1. Direct Exhaust – Use the information in [Figure 23, page 38](#) for air openings.
2. Direct Vent – Use the information in [Figure 24, page 39](#) for air openings.

⚠ WARNING

Air openings must be sized to handle all appliances and air movers, such as exhaust fans, using the air supply. Failure to comply can result in severe personal injury, death, or substantial property damage.

The sizing given in [Figure 23, page 38](#) and [Figure 24, page 39](#) is based on the National Fuel Gas Code – ANSI Z223.1/NFPA 54, latest edition. The sizing allows adequate air openings for gravity-vented gas appliances (Category I) in addition to the needs for the SVF boiler, provided the boiler room is not subjected to negative pressure due to exhaust fans or other mechanical ventilation devices.

The SVF commercial boiler is rated Category IV and has varying requirements for combustion and ventilation air, reflected by the special sizing instructions given in this manual. Refer to the National Fuel Gas Code for dealing with other conditions.

Free area and louvers:

The free area of openings means the area after reduction for any installed louvers or grilles. Be sure to consider this reduction when sizing the air opening.

Special Considerations

Tight construction: The National Fuel Gas Code – ANSI Z223.1/NFPA 54, latest edition, defines unusually tight construction where all of the following is true:

1. Walls and ceilings exposed to the outside atmosphere have a continuous water vapor retarder with a rating of 1 perm or less with openings fitted with gaskets.
2. Weather-stripping has been added on windows and doors that are capable of being opened.
3. Caulking or sealants are applied to areas such as joints around windows and door frames, between sole plates and floors, between wall-ceiling joints, between wall panels, at penetrations for plumbing, electrical, and gas lines, and in other openings.

For buildings with such construction, provide air openings into the building from outside. Size the openings per the appropriate condition in [Figure 23, page 38](#) if appliances are to use inside air for combustion and ventilation.

Exhaust fans and movers: The appliance space must never be under a negative pressure unless all appliances are installed as direct vent. Always provide air openings sized to the dimensions required for the firing rate of all appliances, with the ability to handle the air movement rate of the exhaust fans or air movers using air from the building or space.

The damper/louver control can also provide 120V to operate a damper, and can provide input for a closure switch to allow the damper to prove it is in the open position.

Room Air Openings, continued

Figure 23 Minimum combustion air openings for DIRECT EXHAUST applications

<p>Air openings The required air opening sizes below are FREE AREA, after reduction for louver obstruction. See the important below for large spaces.</p>	<p>SVF boiler WITH other appliances in the same room</p>	<p>SVF boiler WITHOUT other appliances in the same room</p>
	<p>Two openings, each at least: 1 square inch per 1,000 Btuh of all appliances in the room, but not less than 100 in².</p>	<p>Two openings, each at least: 1 square inch per 1,000 Btuh of all appliances in the room, but not less than 100 in².</p>
	<p>Two openings, each at least: 1 square inch per 2,000 Btuh of all appliances in the room -OR- One opening* at least: 1 square inch per 3,000 Btuh of all appliances in the room</p>	<p>Two openings, each at least: 1 square inch per 2,000 Btuh of all appliances in the room -OR- One opening* at least: 1 square inch per 3,000 Btuh of all appliances in the room</p>
	<p>Two openings, each at least: 1 square inch per 4,000 Btuh of all appliances in the room -OR- One opening* at least: 1 square inch per 3,000 Btuh of all appliances in the room</p>	<p>Two openings, each at least: 1 square inch per 4,000 Btuh of all appliances in the room -OR- One opening* at least: 1 square inch per 3,000 Btuh of all appliances in the room</p>
	<p>Two openings, each at least: 1 square inch per 2,000 Btuh of all appliances in the room -OR- One opening* at least: 1 square inch per 3,000 Btuh of all appliances in the room</p>	<p>Two openings, each at least: 1 square inch per 2,000 Btuh of all appliances in the room -OR- One opening* at least: 1 square inch per 3,000 Btuh of all appliances in the room</p>
<p>* Requirements for using the single air opening option</p>	<p>A single combustion air opening can be used for cases b, c, or d above, sized as listed, provided that the following are met:</p> <ul style="list-style-type: none"> • The single opening must communicate directly to open air outside of the building or to a space that communicates directly to the outside of the building. • The top of the opening must be within 12" of the ceiling. • The free area of the opening must be at least equal to the sum of the areas of all equipment vent connectors in the space. 	
<p>IMPORTANT A special exception exists for large spaces. See the information to the right.</p>	<p>No combustion air openings are needed when the boiler and other appliances are installed in a space with a volume no less than 50 cubic ft. per 1,000 Btuh of all appliances in the space. The building must NOT be of tight construction.</p> <p>Calculation: Take the total inputs of all appliances in MBH (1,000s Btuh) and multiply by 50. The space volume must be equal to or greater than the total of this calculation. [Total appliances input in MBH x 50] ≥ space volume</p> <p>Example: For a total input of 1500 MBH (1,500,000 Btuh), the minimum space volume necessary would be 1500 x 50 = 75,000 cubic ft.</p>	

Figure 24 Minimum combustion air openings for DIRECT VENT applications

<p>Air openings The required air opening sizes below are FREE AREA, after reduction for louver obstruction. See the important below for large spaces.</p>	<p>SVF boiler WITH other appliances in the same room</p>	<p>SVF boiler WITHOUT other appliances in the same room</p>
	<p>Two openings, each at least: 1 square inch per 1,000 Btuh of all appliances in the room, but not less than 100 in².</p>	
	<p>Two openings, each at least: 1 square inch per 2,000 Btuh of all appliances in the room -OR- One opening* at least: 1 square inch per 3,000 Btuh of all appliances in the room</p>	<p>No openings are required if the boiler installation provides at least the recommended service clearances shown on page 11</p>
	<p>Two openings, each at least: 1 square inch per 2,000 Btuh of all appliances in the room -OR- One opening* at least: 1 square inch per 3,000 Btuh of all appliances in the room</p>	<p>If the space is smaller, provide one opening to a room with at least 1 square inch per 3,000 Btuh of boiler input</p>
	<p>Two openings, each at least: 1 square inch per 2,000 Btuh of all appliances in the room -OR- One opening* at least: 1 square inch per 3,000 Btuh of all appliances in the room</p>	
<p>* Requirements for using the single air opening option</p>	<p>A single combustion air opening can be used for cases b, c, or d above, sized as listed, provided that the following are met:</p> <ul style="list-style-type: none"> • The single opening must communicate directly to open air outside of the building or to a space that communicates directly to the outside of the building. • The top of the opening must be within 12" of the ceiling. • The free area of the opening must be at least equal to the sum of the areas of all equipment vent connectors in the space. 	
<p>IMPORTANT A special exception exists for large spaces. See the information to the right.</p>	<p>No combustion air openings are needed when the boiler and other appliances are installed in a space with a volume no less than 50 cubic ft. per 1,000 Btuh of all appliances in the space. The building must NOT be of tight construction.</p> <p>Calculation: Take the total inputs of all appliances in MBH (1,000s Btuh) and multiply by 50. The space volume must be equal to or greater than the total of this calculation. [Total appliances input in MBH x 50] ≥ space volume</p> <p>Example: For a total input of 1500 MBH (1,500,000 Btuh), the minimum space volume necessary would be 1500 x 50 = 75,000 cubic ft.</p>	

Room Air Openings, continued

Combustion Air Manifold Option – Category IV Only

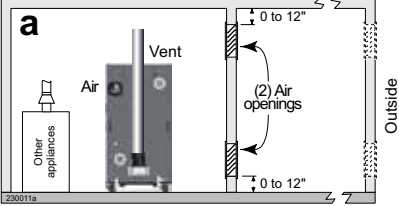
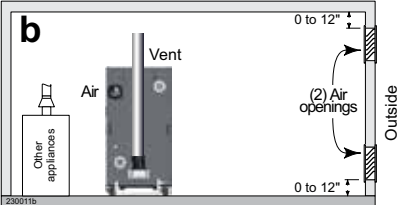
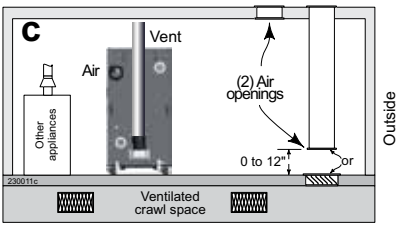
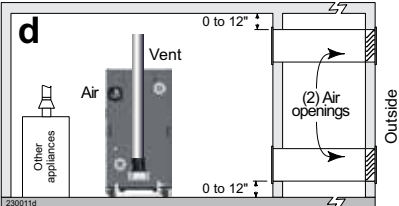
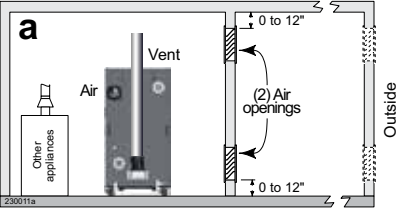
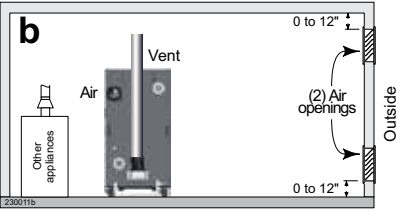
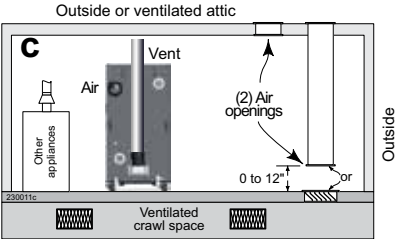
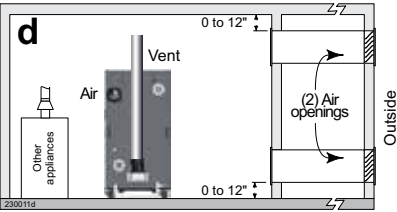
Multiple Category IV SVF boilers can use a common combustion air manifold. Size the duct to provide at least one square inch per 2,000 Btuh total input of connected boilers. Provide a minimum clearance to adjacent vents and grade or snow line as shown in Figure 25.

Provide minimum free area in duct, adjusted for louver restriction, of one square inch per 2,000 Btuh total boiler input. Calculate by dividing the total MBH by two. Example: For an MBS system with total input of 3,000 MBH (3,000,000 Btuh), minimum free area for a combined air duct would be $3,000 \div 2 = 1500$ square inches.

⚠ WARNING

DO NOT use combined Category IV vent piping; only air inlet piping can be combined. Flue gas leakage and boiler component damage can occur if vent piping is combined. Failure to comply can result in severe personal injury, death, or substantial property damage.

Figure 25 Manifolded combustion air option - DIRECT VENT only

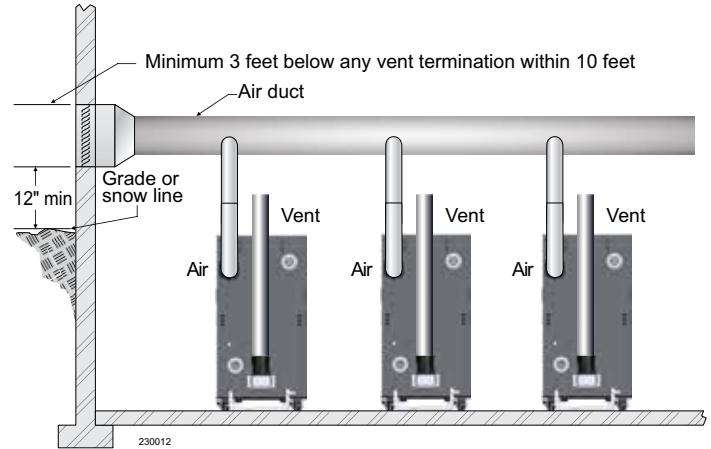

DIRECT EXHAUST — Vertical Termination (Cat. II and IV)

Vertical Termination Location

The vent termination must be installed as shown in Figure 26. The termination placement must comply with clearances and limitations shown in [Figure 27](#), page 43.

NOTICE

A bird screen must be added to the inlet adapter to prevent large debris from entering the boiler cabinet.

1. Install the termination in a location where damage from foreign objects and buildup of leaves or sediment is unlikely.
2. Ensure proper clearance above grade or snow line. Keep vents and air area clear of accumulating snow.
3. Install the boiler in a location that allows proper routing of all vent piping from the boiler vent connection to the selected vertical location.

WARNING

Locate the termination such that the total vent piping from the boiler to the termination will not exceed the maximum length given in [Figure 22](#), page 36 for Category IV venting. Failure to comply can result in severe personal injury, death, or substantial property damage.

Multiple Vent Terminations

When terminating multiple SVF boilers, terminate each vent connection as described in this manual.

For U.S. installations, place wall penetrations to obtain minimum clearances shown in Figure 26.

For Canadian installations, provide clearances required by Natural Gas and Propane Installation Code – CAN/CSA B149.1. Use a ULC S636 compliant vent kit.

IMPORTANT

Read and follow all instructions in this manual. Do not proceed with vent installation until you have read pages 29-43. Comply with all vent system manufacturer's instructions.

Figure 26 Vertical direct exhaust termination

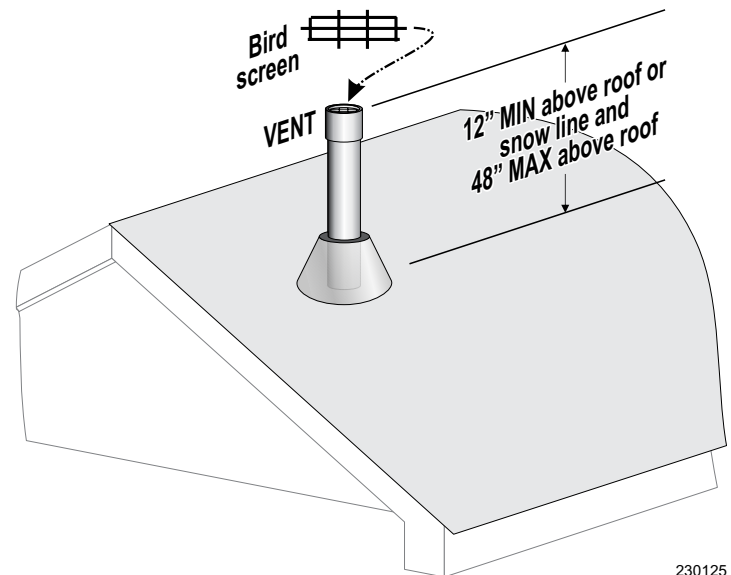

230125

DIRECT EXHAUST — Vertical Termination (Cat. II and IV), continued**Vent Piping Installation****⚠WARNING**

Use only the vent materials and kits listed in [Table 9, page 33](#). Failure to comply can result in severe personal injury, death, or substantial property damage.

⚠WARNING

Every joint on polypropylene vent piping must include a locking collar. Failure to supply locking collars could cause vent or air piping leakage, which can result in severe personal injury or death.

⚠WARNING

Use sweep elbows for all vent and air piping. DO NOT use short-radius elbows for vent or air piping. Failure to comply can result in severe personal injury, death, or substantial property damage.

See [Figure 22, page 36](#) for maximum lengths and reductions required for fittings.

1. Install a vent adapter if needed. Follow instructions from the vent manufacturer.
2. Install a reducer from a vent manufacturer if needed to adapt to the vent size.
3. Slope vent piping toward the boiler a minimum of 1/4" per foot in horizontal runs or larger per vent pipe manufacturer's instructions.
4. Support piping independently of the boiler. Install pipe supports every 5 ft. on both the horizontal and vertical runs. Install a hanger support within 6" of any upturn in the piping.

Vent Termination Installation

1. Vent pipe penetration:
 - a. Cut a hole for the vent pipe.
 - b. For combustible construction, size the vent pipe hole at least 3/8" larger than the vent pipe diameter. Size larger if specified by the vent manufacturer.
 - c. For noncombustible construction, size the opening per vent manufacturer's instructions.
 - d. Insert a corrosion-resistant metal thimble in the vent pipe hole.
 - e. Follow all local codes for isolation of the vent pipe when passing through floors, ceilings, and roofs.
2. Provide flashing and sealing boots sized for the vent pipe.
3. Use a coupling or open-end pipe termination. Follow the guidelines from the vent manufacturer for vertical terminations.
4. Install a bird screen from the vent manufacturer in the open end of the termination.
5. Maintain the required dimensions of the finished termination piping as shown in [Figure 26, page 41](#). Follow the vent or air pipe manufacturer's instructions for proper protection and support of the piping.

⚠WARNING

Do not exceed the maximum length of the outside vent piping shown in [Figure 26, page 41](#). Excessive length exposed to the outside can cause freezing of condensate in the vent pipe, or vent and air piping failure, which can result in severe personal injury, death, or substantial property damage.

DIRECT EXHAUST — Sidewall Termination (Category IV)

Sidewall Termination Location

⚠ WARNING

Follow all location requirements in this section. Failure to comply can result in severe personal injury, death, or substantial property damage.

- The minimum distance from adjacent public walkways, adjacent buildings, windows that can open, and building openings shall not be less than the values specified in the National Fuel Gas Code – ANSI Z223.1/NFPA 54, latest edition, or the National Gas and Propane Installation code – CAN/CSA B149.1.

- Vent and air terminations must be installed at least 12" (0.31m) above grade and snow line.
- Consideration should be given to avoid possible damage caused by vent plumes and condensate when choosing a venting configuration and location.
- Maintain a minimum clearance of 4 ft. (1.22 m) horizontally from electrical meters, gas meters, regulators, and relief equipment. Do not install above or below meters, regulators, or relief equipment.

Figure 27 Direct exhaust installation requirements for termination location

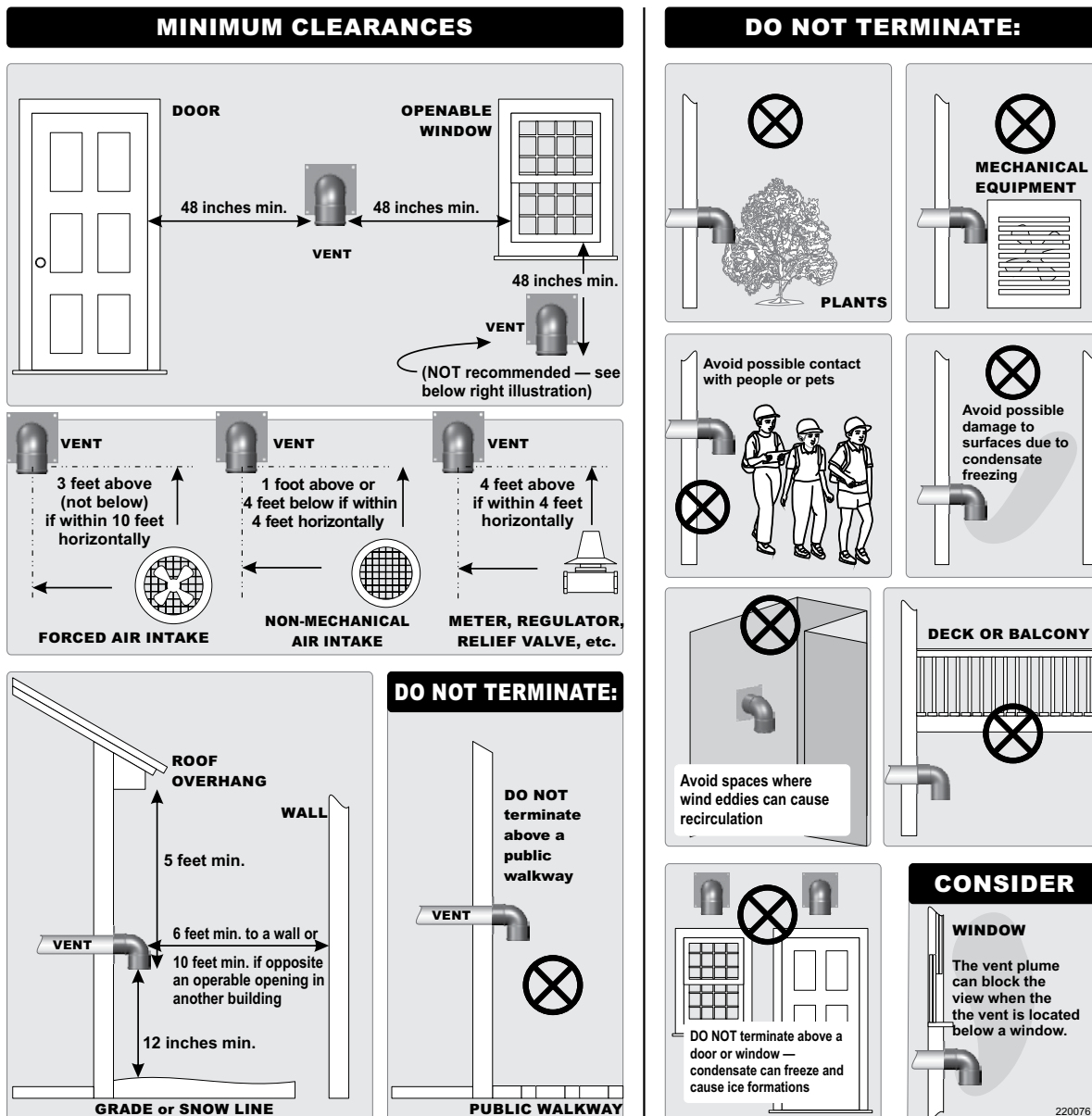

DIRECT EXHAUST — Sidewall Termination (Category IV), continued

Determine Termination Location

The vent termination must be installed as shown in Figure 28 and Figure 30, page 45. The termination placement must comply with clearances and limitations shown in Figure 27, page 43.

1. Install the termination in a location where damage from foreign objects and buildup of leaves or sediment is unlikely.
2. Ensure proper clearance above grade or snow line. Keep vents and air area clear of accumulating snow.
3. Install the boiler in a location that allows proper routing of all vent piping from the boiler vent connection to the selected sidewall location.

⚠WARNING

Locate the termination such that the total vent piping from the boiler to the termination will not exceed the maximum length given in Figure 22, page 36 for Category IV venting. Failure to comply can result in severe personal injury, death, or substantial property damage.

IMPORTANT

Read and follow all instructions in this manual. Do not proceed with vent installation until you have read pages 29-43. Comply with all vent system manufacturer's instructions.

Multiple Vent Terminations

When terminating multiple SVF boilers, terminate each vent connection as described in this manual. See Figure 29, page 45 for a typical layout.

For U.S. installations, place wall penetrations to obtain minimum clearances shown in Figure 28.

For Canadian installations, provide clearances required by Natural Gas and Propane Installation Code – CAN/CSA B149.1. Use a ULC S636-compliant vent kit.

Vent Piping Installation

⚠WARNING

Use only the materials and kits in Table 9, page 33. Failure to comply can result in severe personal injury, death, or substantial property damage.

Figure 28 Sidewall direct exhaust termination

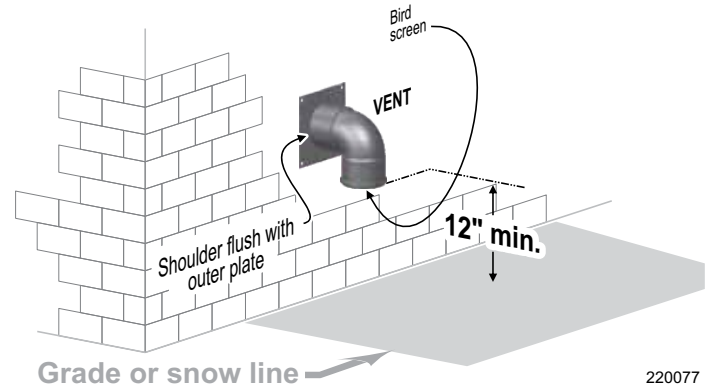

⚠WARNING

Every joint on polypropylene vent piping must include a locking collar. Failure to supply locking collars could cause vent or air piping leakage, which can result in severe personal injury or death.

⚠WARNING

Use sweep elbows for all vent and air piping. DO NOT use short-radius elbows for vent or air piping. Failure to comply can result in severe personal injury, death, or substantial property damage.

See Figure 22, page 36 for maximum lengths and reductions required for fittings.

1. Install a vent adapter if needed. Follow instructions from the vent manufacturer.
2. Install a reducer from a vent manufacturer if needed to adapt to the vent size.
3. Slope vent piping toward the boiler a minimum of 1/4" per foot in horizontal runs or larger per vent pipe manufacturer's instructions.
4. Support piping independently of the boiler. Install pipe supports every 5 ft. on both the horizontal and vertical runs. Install a hanger support within 6" of any upturn in the piping.

Vent Termination Installation

Maintain the required dimensions of the finished termination piping as shown in Figure 27, page 43.

1. Vent pipe penetration
 - a. Cut a hole for the vent pipe
 - b. For combustible construction, size the vent pipe hole at least 3/8" larger than the vent pipe diameter. Size larger if specified by the vent manufacturer.
 - c. For noncombustible construction, size the opening per vent manufacturer's instructions.
 - d. Insert a corrosion-resistant metal thimble in the vent pipe hole as shown in Figure 30.
 - e. Follow all local codes for isolation of vent pipe when passing through floors, ceilings, and roofs.
2. Provide and install corrosion-resistant metal stop plates. See Figure 30, item 3.
 - a. The hole size in the stop plates must be just larger than the vent pipe diameter.
 - b. Obtain stop plates only from the vent pipe manufacturer.
3. Insert the last length of vent pipe from the outside. The shoulder of the vent pipe female end must rest against the outer stop plate as shown. The plate must prevent the vent from being pushed inward.
4. Insert the termination elbow into the vent pipe end.
5. Install a bird screen from the vent manufacturer in the open end of the termination.
6. Seal exterior openings thoroughly with exterior caulk.
7. See Figure 29 for multiple boiler terminations.

⚠ WARNING

Do not exceed the maximum length of the outside vent piping shown in Figure 26, page 41. Excessive length exposed to the outside can cause freezing of condensate in the vent pipe, or vent and air piping failure. Follow vent or air pipe manufacturer's instructions for proper protection and support of the piping. Failure to comply can result in severe personal injury, death, or substantial property damage.

Figure 29 Multiple boiler direct exhaust sidewall terminations

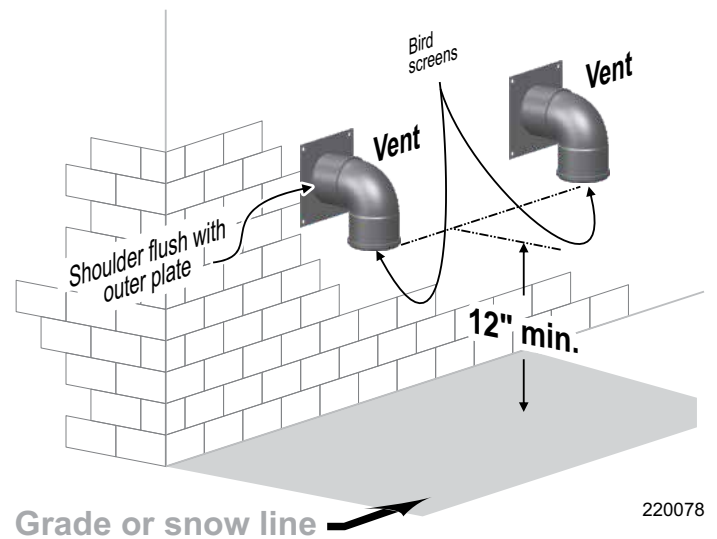
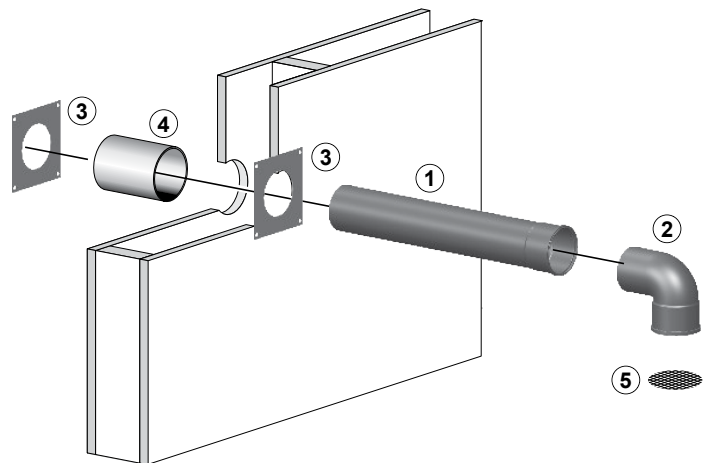

Figure 30 Sidewall termination assembly for direct exhaust installations



- | | |
|--|--|
| 1. Insert vent piping from the outside until the female end shoulder rests against the outside stop plate. | 3. Vent manufacturer's sidewall stop plates (hole must be just larger than the vent diameter). |
| 2. Use a down-turned 90-degree elbow for termination. | 4. Corrosion-resistant thimble, by installer |
| | 5. Bird screen, by installer |

DIRECT VENT — Vertical Termination (Category IV)

Vertical Termination Location

The vent and air terminations must be installed as shown in Figure 31. The air termination can be through either the roof or a sidewall as shown. The termination placement must comply with clearances and limitations shown on the following pages.

1. Install the termination in a location where damage from foreign objects and buildup of leaves or sediment is unlikely.
2. Ensure proper clearance above grade or snow line. Keep vents and air area clear of accumulating snow.
3. Install the boiler in a location that allows proper routing of all vent piping from the boiler vent connection to the selected sidewall location.

WARNING

Locate the termination such that the total vent piping from the boiler to the termination will not exceed the maximum length given in [Figure 22, page 36](#) for Category IV venting. Failure to comply can result in severe personal injury, death, or substantial property damage.

IMPORTANT

Read and follow all instructions in this manual. Do not proceed with vent installation until you have read [pages 29-40, & 49](#). Comply with all vent system manufacturer's instructions.

Multiple Vent Terminations

When terminating multiple SVF boilers, terminate each vent connection as described in this manual. See [Figure 38, page 50](#) for typical sidewall air termination layouts.

For U.S. installations, place roof penetrations to obtain a minimum clearance of 12" between edge of air inlet elbow and adjacent vent pipe of another boiler as shown in [Figure 33, page 47](#).

For Canadian installations, provide clearances required by Natural Gas and Propane Installation Code – CAN/CSA B149.1. Use a ULC S636-compliant vent kit.

Figure 31 Vertical direct vent terminations

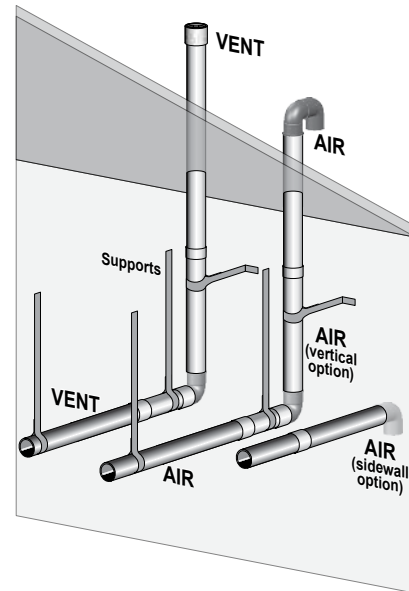

Vent Piping Installation

WARNING

Use only vent materials listed in [Table 9, page 33](#). Failure to comply can result in severe personal injury, death, or substantial property damage.

WARNING

Every joint on polypropylene vent piping must include a locking collar. Failure to supply locking collars could cause vent or air piping leakage, which can result in severe personal injury or death.

WARNING

Use sweep elbows for all vent and air piping. DO NOT use short-radius elbows for vent or air piping. Failure to comply can result in severe personal injury, death, or substantial property damage.

1. Install a vent adapter if needed. Follow instructions from the vent manufacturer.
2. Install a reducer from a vent manufacturer if needed to adapt to the vent size.
3. Slope vent piping toward the boiler a minimum of 1/4" per foot in horizontal runs or larger per vent pipe manufacturer's instructions.
4. Support piping independently of the boiler. Install pipe supports every 5 ft. on both the horizontal and vertical runs. Install a hanger support within 6" of any upturn in the piping.

Vent and Air Termination Installation

Maintain the required dimensions of the finished termination piping as shown in the figures in this section.

⚠ WARNING

Terminate all vent pipes the same height and all air pipes at the same height. Failure to comply can result in severe personal injury, death, or substantial property damage.

1. Air pipe penetration:
 - a. Cut a hole for the air pipe, sized per the manufacturer's instructions.
2. Vent pipe penetration
 - a. Cut a hole for the vent pipe
 - b. For combustible construction, size the vent pipe hole at least 3/8" larger than the vent pipe diameter. Size larger if specified by the vent manufacturer.
 - c. For noncombustible construction, size the opening per vent manufacturer's instructions.
 - d. Insert a corrosion-resistant metal thimble in the vent pipe hole.
 - e. Follow all local codes for isolation of vent pipe when passing through floors, ceilings, and roofs.
3. Vertical vent termination, vertical air termination:
 - a. Provide flashing and sealing boots sized for the vent pipe.
 - b. Use a coupling or open-end pipe termination. Follow the guidelines from the vent manufacturer for vertical terminations.
 - c. Install a bird screen from the vent or air manufacturer in the open end of the terminations.

(continued on the next page)

Figure 32 Vertical vent & air terminations

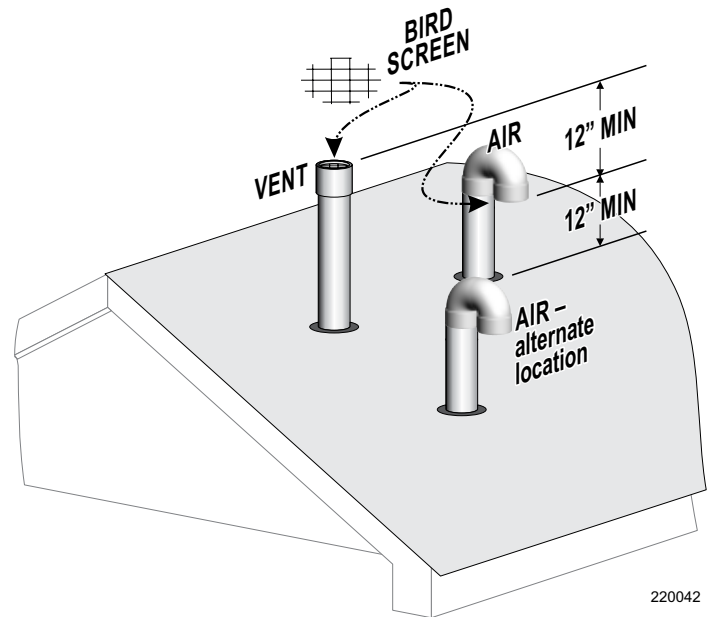
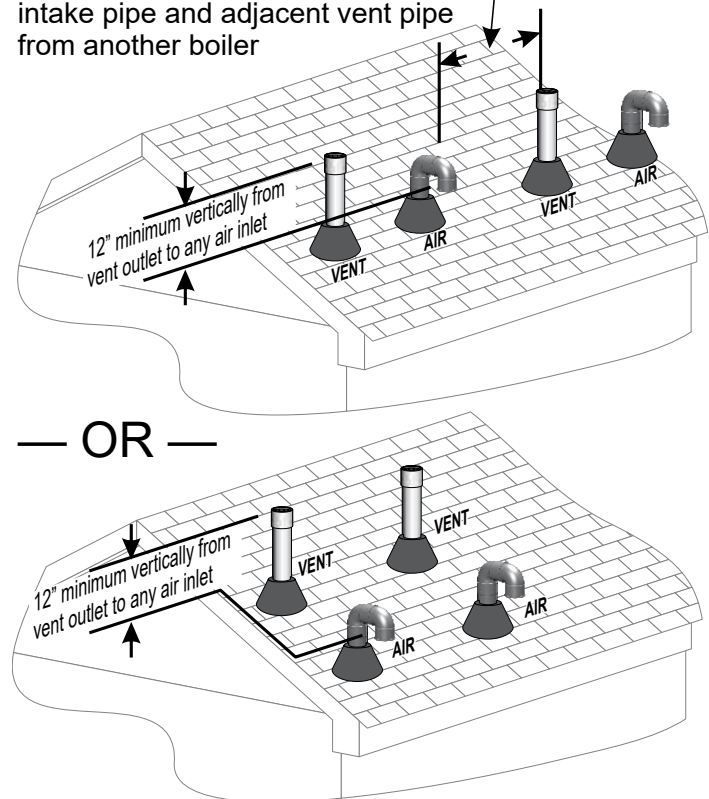

Figure 33 Vertical vent & air piping - termination location for multiple boilers

12" minimum between edge of air intake pipe and adjacent vent pipe from another boiler



DIRECT VENT — Vertical Termination (Category IV), continued

Vent and Air Termination Installation, cont.

4. Vertical vent termination with sidewall air termination as shown in Figure 34:
 - a. Provide and install corrosion-resistant metal stop plates. See Figure 35, item 3.
 - b. The hole size in the stop plates must be just larger than the vent pipe diameter.
 - c. Obtain stop plates only from the vent pipe manufacturer.
 - d. Insert the last length of vent and air pipe from the outside. The shoulders of the vent and air pipe female ends must rest against the outer stop plates as shown. The plates must prevent the vent or air pipe from being pushed inward.
 - e. Attach the termination elbow into the air pipe end.
 - f. Install a bird screen from the vent manufacturer in the open end of the termination.
 - g. Seal exterior openings thoroughly with exterior caulk.

WARNING

For multiple boiler applications, space flue vents a minimum 6" apart from other flue vents, and air terminations a minimum 6" apart from other air terminations. Flue vents must maintain a 12" horizontal distance from air terminations. Failure to comply can result in severe personal injury, death, or substantial property damage.

Figure 34 Vertical vent with sidewall air - termination locations

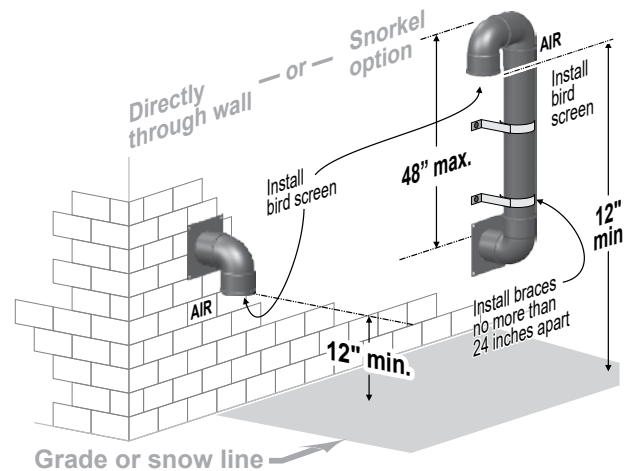
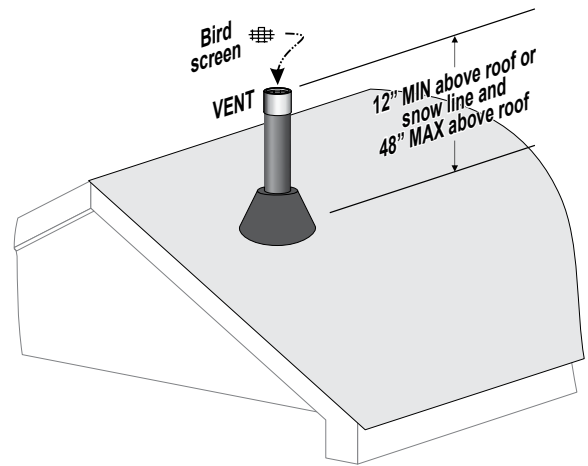
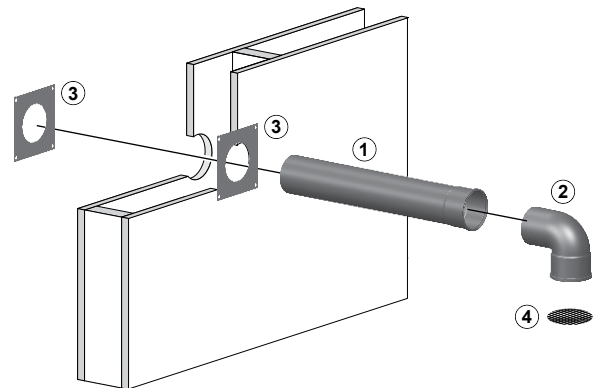

Figure 35 Vertical vent with sidewall air - sidewall air termination assembly



- | | |
|---|---|
| 1. Air piping must extend through wall enough for complete engagement of the air termination elbow. | 3. Sidewall termination plates - hole must be just larger than the air pipe diameter. |
| 2. Air termination elbow - down-turned 90-degree. | 4. Bird screen, by installer. |

DIRECT VENT — Sidewall Separate Pipes (Category IV)

Sidewall Termination Location

⚠ WARNING

Follow all location requirements in this section. Failure to comply can result in severe personal injury, death, or substantial property damage.

- The minimum distance from adjacent public walkways, adjacent buildings, windows that can open, and building openings shall not be less than the values specified in the National Fuel Gas Code – ANSI Z223.1/NFPA 54, latest edition, or the National Gas and Propane Installation code – CAN/CSA B149.1.

- Vent and air terminations must be installed at least 12" (0.31m) above grade and snow line.
- Consideration should be given to avoid possible damage caused by vent plumes and condensate when choosing a venting configuration and location.
- Maintain a minimum clearance of 4 ft. (1.22 m) horizontally from electrical meters, gas meters, regulators, and relief equipment. Do not install above or below meters, regulators, or relief equipment.

Figure 36 Direct Vent Installations - Requirements for termination location

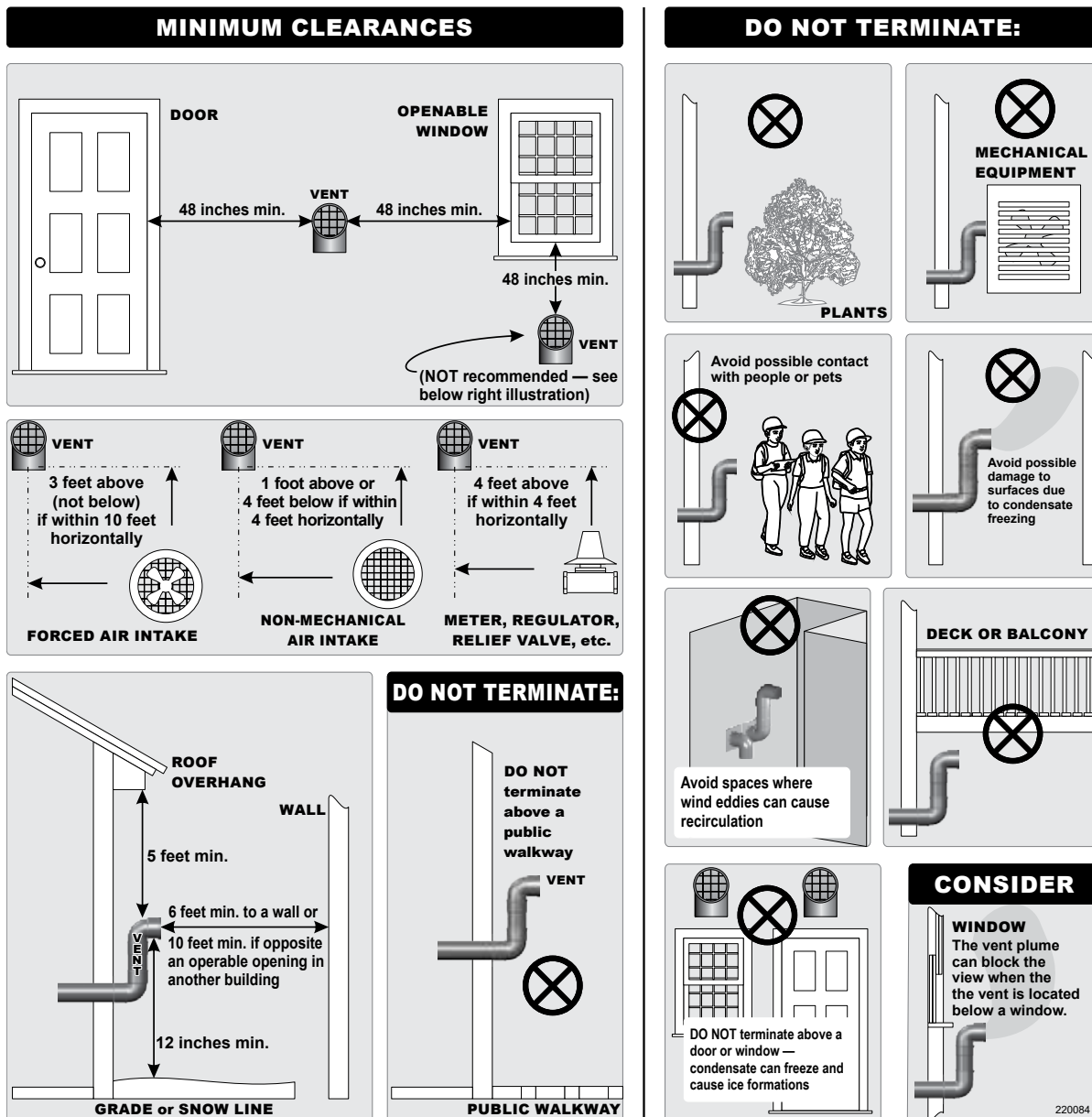

DIRECT VENT — Sidewall Separate Pipes (Category IV), continued

Determine Termination Location

The vent termination must be installed as shown in Figure 37 and Figure 39, page 51. The termination placement must comply with clearances and limitations shown in Figure 36, page 49.

1. Install the termination in a location where damage from foreign objects and buildup of leaves or sediment is unlikely.
2. Ensure proper clearance above grade or snow line. Keep vents and air area clear of accumulating snow.
3. Install the boiler in a location that allows proper routing of all vent piping from the boiler vent connection to the selected sidewall location.

WARNING

Locate the termination such that the total vent piping from the boiler to the termination will not exceed the maximum length given in Figure 22, page 36 for Category IV venting. Failure to comply can result in severe personal injury, death, or substantial property damage.

IMPORTANT

Read and follow all instructions in this manual. Do not proceed with vent installation until you have read pages 29-40 & 49. Comply with all vent system manufacturer's instructions.

Multiple Vent Terminations

When terminating multiple SVF boilers, terminate each vent connection as described in this manual. See Figure 38 for typical layout.

For U.S. installations, place wall penetrations to obtain minimum clearances shown in Figure 37 and Figure 38.

In Canada, provide clearances required by Natural Gas and Propane Installation Code – CAN/CSA B149.1. Use a ULC S636-compliant vent kit.

Figure 37 Sidewall direct vent terminations – separate pipes

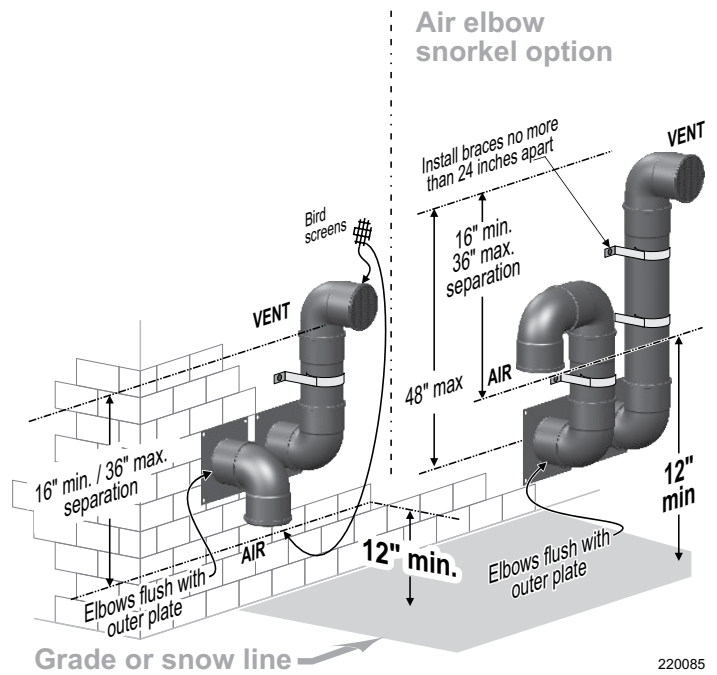
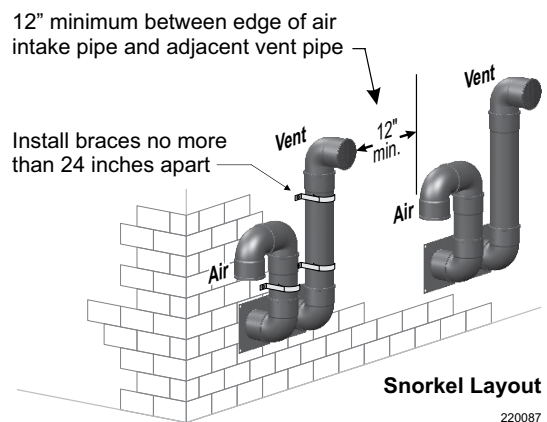
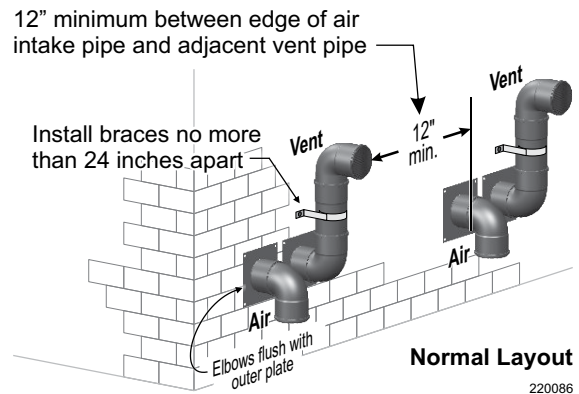

Figure 38 Multiple terminations, separate pipes – clearance from vent of one to air inlet of the next



Vent Piping Installation

⚠ WARNING

Use only the vent materials and kits listed in [Table 9, page 33](#). Failure to comply can result in severe personal injury, death, or substantial property damage.

⚠ WARNING

Every joint on polypropylene vent piping must include a locking collar. Failure to supply locking collars can cause vent or air piping leakage, which can result in severe personal injury, death, or substantial property damage.

⚠ WARNING

Use sweep elbows for all vent and air piping. DO NOT use short-radius elbows for vent or air piping. Failure to comply can result in severe personal injury, death, or substantial property damage.

1. Install a vent adapter if needed. Follow instructions from the vent manufacturer.
2. Install a reducer from a vent manufacturer if needed to adapt to the vent size.
3. Slope vent piping toward the boiler a minimum of 1/4" per foot in horizontal runs or larger per vent pipe manufacturer's instructions.
4. Support piping independently of the boiler. Install pipe supports every 5 ft. on both the horizontal and vertical runs. Install a hanger support within 6" of any upturn in the piping.

Vent Termination Installation

Maintain the required dimensions of the finished termination piping as shown in [Figure 36, page 49](#).

1. Cut a hole for the air pipe, sized per the air pipe manufacturer's instructions.
2. Vent pipe penetration:
 - a. Cut a hole for the vent pipe
 - b. For combustible construction, size the vent pipe hole at least 3/8" larger than the vent pipe diameter. Size larger if specified by the vent manufacturer.
 - c. For noncombustible construction, size the opening per vent manufacturer's instructions.
 - d. Insert a corrosion-resistant metal thimble in the vent pipe hole as shown in [Figure 39](#).
 - e. Follow all local codes for isolation of vent pipe when passing through floors, ceilings, and roofs.

Figure 39 Sidewall assembly, separate pipes – direct vent

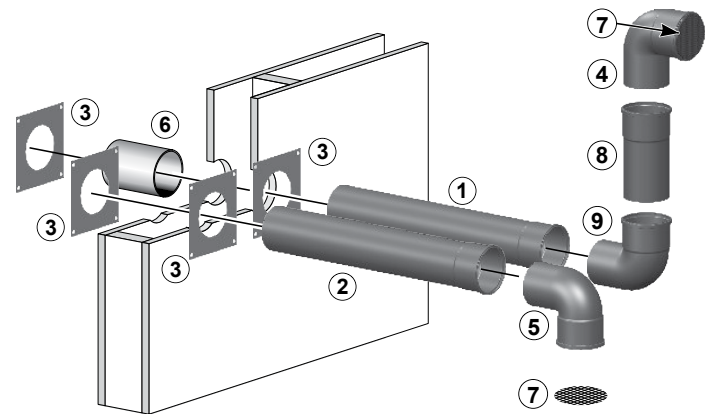

- | | |
|--|---|
| 1. Insert vent piping from the outside until the female end shoulder rests against the outside stop plate. | 4. Vent termination elbow - outward-facing 90-degree. |
| 2. Insert air piping from the outside until the female end shoulder rests against the outside stop plate. | 5. Air termination elbow - down-turned 90-degree. |
| 3. Sidewall termination plates | 6. Corrosion-resistant thimble, by installer. |
| | 7. Bird screen, by installer. |
| | 8. Vent length |
| | 9. Elbow |

3. Provide and install corrosion-resistant metal stop plates. See [Figure 39](#), item 3.
 - a. The hole size in the stop plates must be just larger than the vent pipe diameter.
 - b. Obtain stop plates only from the vent pipe manufacturer.
4. Insert the last lengths of vent and air pipe from the outside. The shoulders of the vent and air pipe female ends must rest against the outer stop plates as shown. The plates must prevent the vent or air pipe from being pushed inward.
5. Individual external vent and air pipes having a total length of up to 4 feet (each) do not require an insulated enclosure to be installed around the piping. The vent and air pipes must be secured with braces. All clearances and lengths must be maintained. Space braces no further than 24" apart.
6. Individual external vent and air pipes having a total length greater than 4 feet (each) must have an insulated enclosure installed around the vent and air pipes to reduce the risk of condensate freezing inside of the exposed piping. The vent and air terminations must exit through the enclosure while maintaining all required clearances. See [Figure 37, page 50](#).
7. Attach the exterior piping and termination elbows.
8. Install a bird screen from the vent manufacturer in the open end of the termination.
9. Seal exterior openings thoroughly with exterior caulk.

DIRECT VENT — Vertical Concentric (Category IV)

Determine Termination Location

The concentric termination kit must be purchased separately (see [page 131](#)). The concentric vent and air inlet assembly must terminate as shown in [Figure 42](#), [page 53](#). The termination must comply with clearances and limitations shown in [Figure 36](#), [page 49](#).

⚠ WARNING

Locate the termination such that the total vent piping from the boiler to the termination will not exceed the maximum length given in [Figure 22](#), [page 36](#) for Category IV venting. Failure to comply can result in severe personal injury, death, or substantial property damage.

IMPORTANT

Read and follow all instructions in this manual. Do not proceed with installation until you have read [pages 29-40 & 49](#). Comply with all vent system manufacturer's instructions.

1. This termination requires a 45-degree elbow that is not supplied with the termination kit. The maximum vent and air inlet pipe lengths include allowance for this elbow.
2. Install the termination in a location where damage from foreign objects and buildup of leaves or sediment is unlikely.
3. For Canadian installations, follow the requirements of the Natural Gas and Propane Installation Code, CAN/CSA B149.1 or B149.2. Use a ULC S636 compliant vent kit.

Multiple Vent and Air Inlet Terminations

⚠ WARNING

All vent and air inlet pipes must terminate at the same height. Failure to comply can result in severe personal injury, death, or substantial property damage.

1. When terminating multiple SVF boilers, install the concentric vent and air inlet termination assemblies as described in this manual.
2. Place roof penetrations to obtain a minimum clearance of 12" between edges of adjacent vent pipes of other boilers. See [Figure 41](#), [page 53](#).

Figure 40 Concentric vertical installation

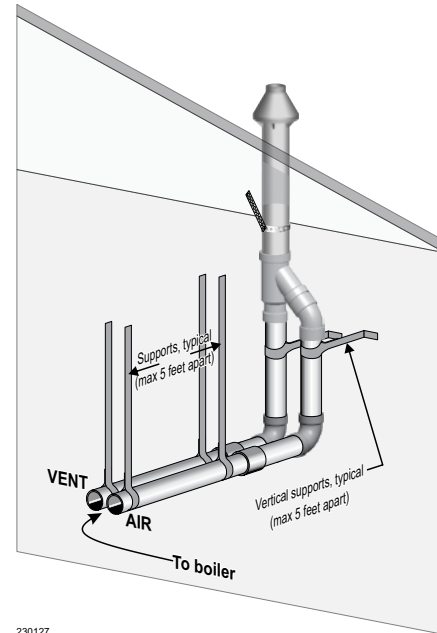

3. The air inlet of a boiler is part of a direct vent connection. It is not classified as a forced air intake with regard to spacing from adjacent boiler vents.

Concentric Piping Termination Installation

1. Prepare the roof penetrations.
 - a. Cut a clearance hole to clear the termination outside diameter as prescribed in the concentric termination kit instructions.
 - b. Insert a corrosion resistant metal thimble in the vent pipe hole.
 - c. Follow all local codes for isolation of vent pipe when passing through floors, ceilings and roofs.
 - d. Provide flashing and sealing boots sized for the concentric termination outside diameter.
2. Assemble the vent termination as described for concentric terminations, on [page 54](#).
3. Mount the termination as in [Figure 42](#), [page 53](#).
 - a. When inserting the partially-assembled termination kit through the roof penetration, wrap plastic or other protection over the end of the exposed assembly to prevent debris from entering the pipes.
 - b. If air passages become blocked, the boiler will not operate. Once the rain cap has been cemented to the assembly, there is no way to correct blockages, and the assembly must be replaced.

Concentric Piping Termination Installation, cont.

4. Support the concentric vent/air termination at the roof penetration as shown in Figure 42, or per concentric kit instructions.
 - a. The supports/bracing used must support the termination assembly to prevent vertical slippage or sideways movement.
 - b. The clamps used on the outside of the termination pipe must not cut into the pipe or contain sharp edges that could cause a crack to form.

⚠ WARNING

The vent and air piping must be securely supported, and must not rest its weight on the boiler fittings. Do not drill or screw into either the vent or air inlet pipe. Failure to properly support the vent and air piping could cause vent piping damage, which can result in severe personal injury, death or substantial property damage.

⚠ WARNING

Do not connect any other appliance to the vent pipe or multiple boilers to a common vent pipe. Failure to comply can result in severe personal injury, death, or substantial property damage.

5. After the assembly has been positioned in the opening and all supports have been attached, install a bird screen and rain cap. Refer to [Figure 43, page 54](#)
 - a. Place the bird screen on the end of the inner pipe as shown, or per the concentric kit instructions for polypropylene kits.
 - b. Cement the rain cap in place as shown.

Vent Piping Installation

⚠ WARNING

Every joint on polypropylene vent piping must include a locking collar. Failure to supply locking collars can cause vent or air piping leakage, which can result in severe personal injury, death, or substantial property damage.

⚠ WARNING

Use sweep elbows for all vent and air piping. DO NOT use short-radius elbows for vent or air piping. Failure to comply can result in severe personal injury, death, or substantial property damage.

Figure 41 Concentric vertical termination – single or multiple boilers

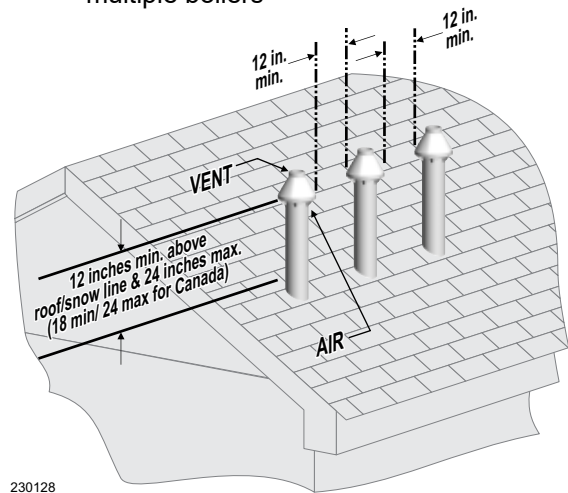
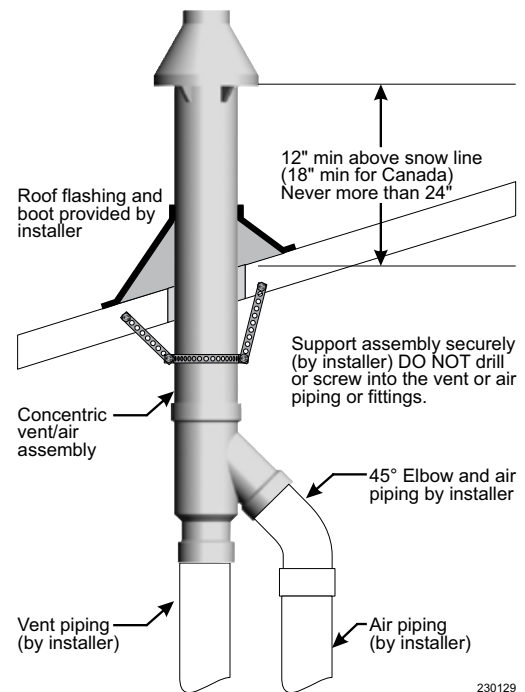

Figure 42 Concentric termination supports



1. The termination must be assembled and installed before piping from the boiler to the termination. See the previous section and kit for instructions.
2. Install a vent adapter or reducer if needed. Follow instructions from the vent manufacturer.
3. Install vent and air piping between the boiler and the concentric termination. Slope vent piping toward the boiler a minimum of 1/4" per foot in horizontal runs, or larger slopes per vent manufacturer's instructions.
4. Support piping independently of the boiler. Install pipe supports every 5 ft. on both the horizontal and vertical runs. Install a hanger support within 6" of any upturn in the piping.

Concentric Termination, Typical

Assembling Concentric Terminations

Follow all instructions provided with the concentric termination kit. The following are general guidelines for information only.

1. The typical assembly of a concentric termination assembly is shown in Figure 43. See the kit instructions for details of polypropylene kits.

⚠WARNING

DO NOT install the rain cap and bird screen until the assembly has been inserted through the roof or sidewall, and all supports have been installed. Cover the end of the assembly with plastic before inserting through the penetration to prevent debris from blocking the air passages. Failure to comply can result in severe personal injury, death, or substantial property damage.

2. Prepare the bird screen (item 4). Cut the bird screen to size if required. If the bird screen must be trimmed, cut the bird screen to fit the outside diameter of the PVC inner pipe supplied with the termination kit.
3. Partially assemble the vent termination kit in the sequence shown in Figure 43, or per the concentric kit instructions.
4. If necessary, the lengths of the inner and outer pipes can be shortened for a shorter finished assembly. Ensure the pipes connect correctly at both ends.

⚠WARNING

Follow all instructions in this manual for concentric termination assemblies. Failure to properly assemble the concentric termination can cause flue gas recirculation, which can result in severe personal injury or death.

Figure 43 Concentric termination assembly

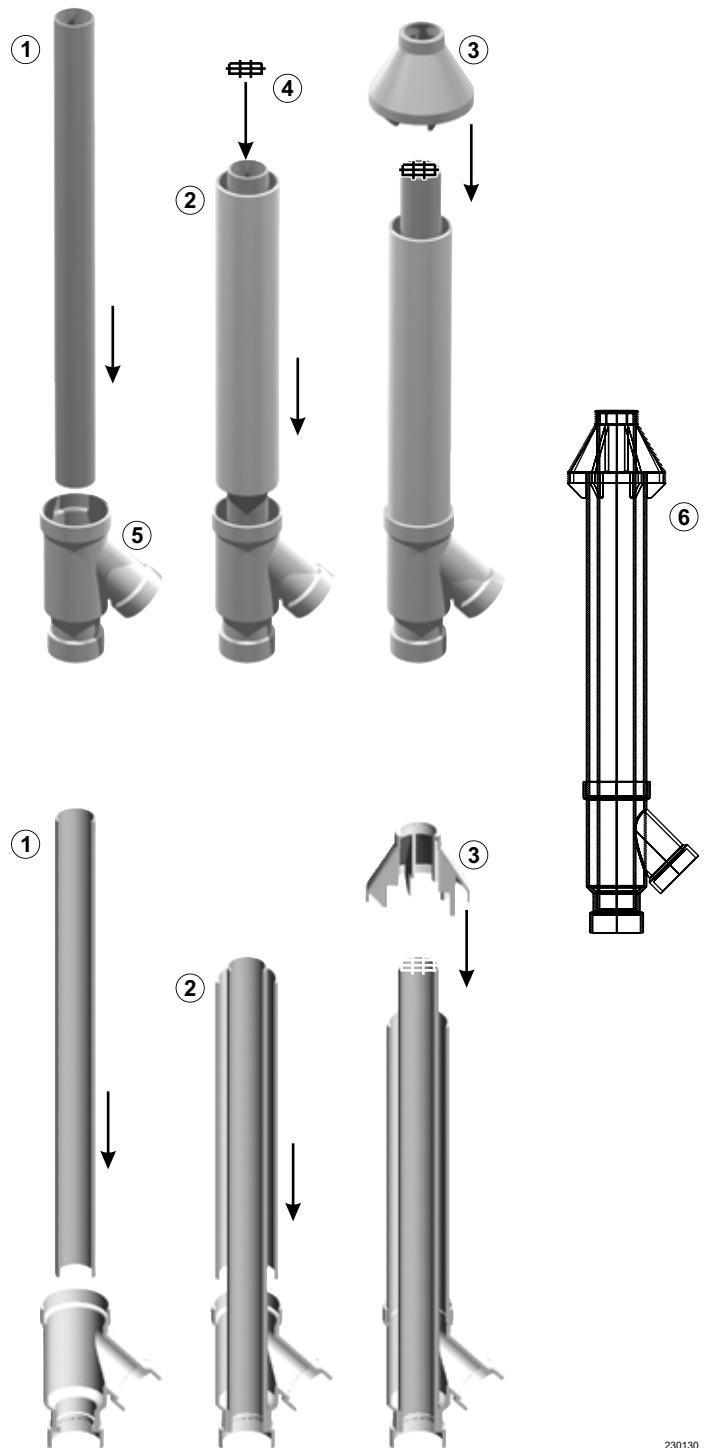

- | | |
|-------------------------------|----------------------|
| 1. Inner PVC pipe (vent) | 4. Bird screen |
| 2. Outer PVC pipe (air inlet) | 5. Y-fitting |
| 3. Rain cap | 6. Finished assembly |

230130

DIRECT VENT — Sidewall Concentric (Category IV)

Determine Termination Location

The concentric termination kit (purchased separately) must be installed as shown in Figure 44 and Figure 46, page 56. The termination placement must comply with clearances and limitations shown in Figure 36, page 49.

WARNING

Locate the termination such that the total vent piping from the boiler to the termination will not exceed the maximum length given in Figure 22, page 36 for Category IV venting. Failure to comply can result in severe personal injury, death, or substantial property damage.

IMPORTANT

Read and follow all instructions in this manual. Do not proceed with installation until you have read pages 29-40 & 49. Comply with all vent system manufacturer's instructions.

1. This termination requires a 45-degree elbow that is not supplied with the termination kit. The maximum vent and air pipe lengths include allowance for this elbow.
2. Install the termination in a location where damage from foreign objects and buildup of leaves or sediment is unlikely.
3. Ensure proper clearance above grade or snow line. Keep vents and air area clear of accumulating snow.
4. Install the boiler in a location that allows proper routing of all vent piping from the boiler vent connection to the selected sidewall location.

Multiple Vent and Air Inlet Terminations

When terminating multiple SVF boilers, terminate each concentric termination as described in this manual. See Figure 45 for typical layout.

WARNING

All vent and air inlet pipes must terminate at the same height. Failure to comply can result in severe personal injury, death, or substantial property damage.

Figure 44 Sidewall direct vent terminations – concentric

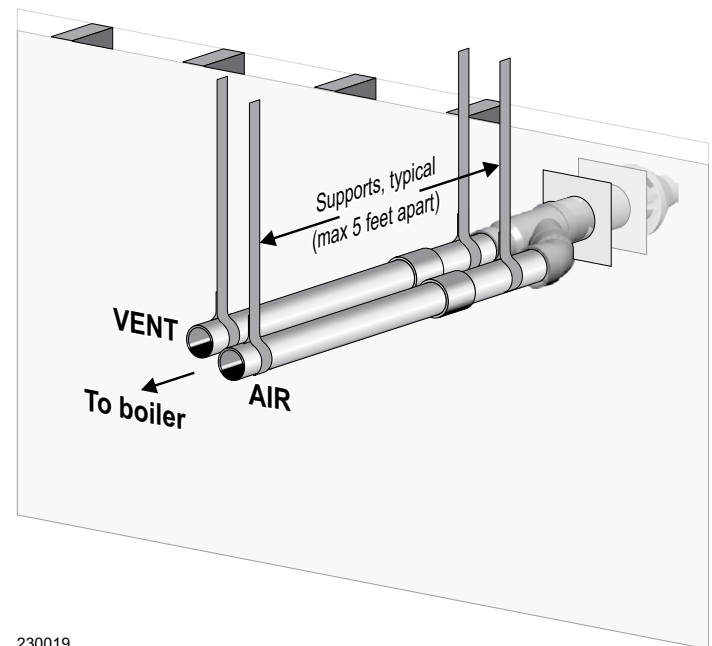

230019

Figure 45 Multiple terminations, concentric – clearance from vent of one to air inlet of the next

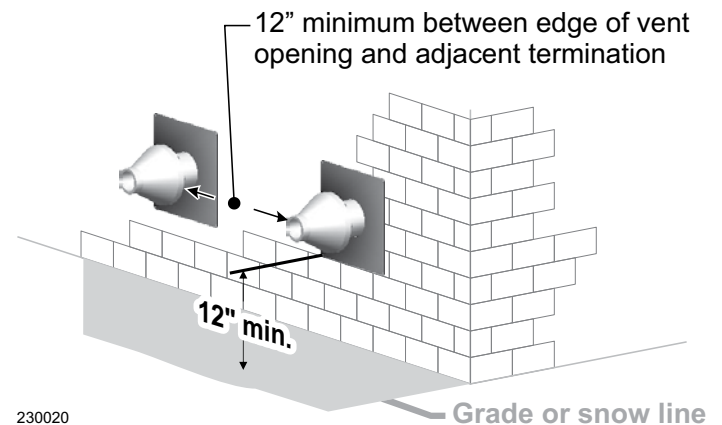

230020

- For U.S. installations, place wall penetrations to obtain minimum clearances shown in Figure 45 and Figure 36, page 49.
- In Canada, provide clearances required by the Installation Code – CAN/CSA B149.1 or B149.2. Use a ULC S636-compliant vent kit.
- The air inlet of a boiler is part of a direct vent connection. It is not classified as a forced air intake with regard to spacing from adjacent boiler vents.

DIRECT VENT — Sidewall Concentric (Category IV), continued

Concentric Piping Termination Installation

⚠WARNING

Use only the vent materials and kits listed in Table 9, page 33. Failure to comply can result in severe personal injury, death, or substantial property damage.

1. Assemble the vent termination as described for concentric terminations on page 54.
2. Using a thimble with a 4-1/2" hole is the preferred method for wall penetration.
 - a. If not using a thimble, carefully use a hole saw to cut a hole no larger than 4-3/4" in diameter through the wall. The finished hole must provide a solid stop for the rain cap ribs. See the inset in Figure 46.
 - b. Ensure the wall material is strong enough to prevent the rain cap from being pushed inward if struck or pushed from the outside.
3. Secure the termination in place so the rain cap abuts the outside wall or outer thimble plate as shown in Figure 46.
4. Before beginning vent and air piping from the boiler to the concentric termination, mount and secure the concentric termination as shown in Figure 46.
 - a. When inserting the partially-assembled termination kit through the wall penetration, wrap plastic or other protection over the end of the exposed assembly to prevent debris from entering the pipes.
 - b. If air passages become blocked, the boiler will not operate. Once the rain cap has been cemented to the assembly, there is no way to correct blockages, and the assembly must be replaced.

⚠WARNING

Do not alter the concentric termination assembly. The assembly must be replaced if it needs to be removed and cleaned. Altering the assembly could cause toxic flue product emissions, which can result in severe personal injury or death.

Figure 46 Concentric sidewall vent assembly supports

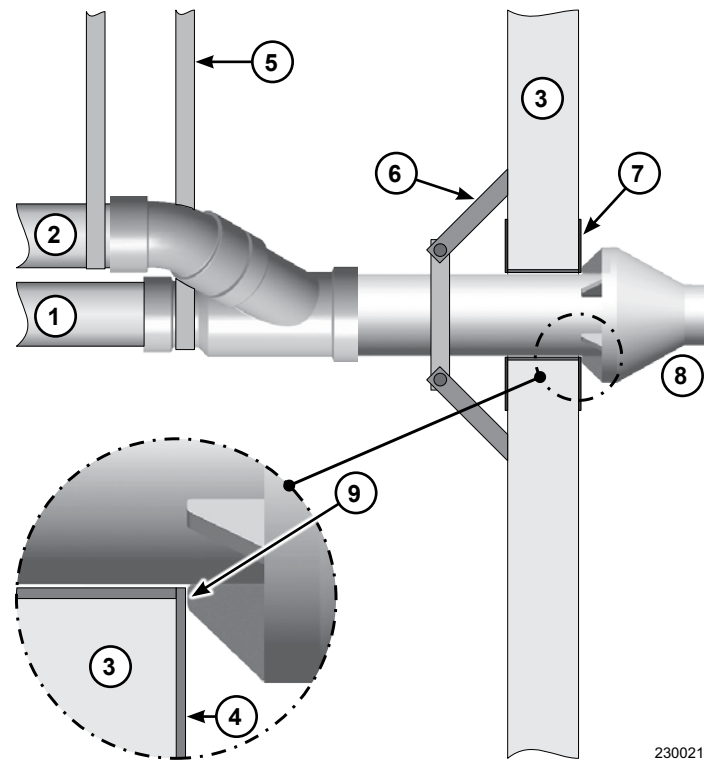

230021

1. Vent pipe	6. Wall brace (by installer), or see vent pipe manufacturer instructions.
2. Air pipe	7. Thimble (by installer)
3. Wall	8. Rain cap
4. Outer thimble plate	9. Rain cap ribs must abut the outer thimble plate or wall opening.
5. Supports at every 5 feet, or per vent pipe manufacturer instructions.	

Concentric Piping Termination Installation, cont.

5. The supports and bracing used must support the termination assembly to prevent slippage or movement. See instructions provided with the concentric kit for details.

⚠WARNING

The vent and air piping must be securely supported, and must not rest its weight on the boiler fittings. Failure to properly support the vent and air piping could cause vent piping damage, which can result in severe personal injury, death or substantial property damage.

6. The clamps used on the outside of the termination pipe must not cut into the pipe or contain sharp edges that could cause a crack to form.
7. Maintain the required dimensions of the finished termination piping as shown in [Figure 36, page 49](#).
8. After the assembly has been positioned in the opening and all supports have been attached, install a bird screen and rain cap. Refer to [Figure 43, page 54](#)
 - a. Place the bird screen on the end of the inner pipe as shown, or per the concentric kit instructions for polypropylene kits.
 - b. Cement the rain cap in place as shown.
9. Seal exterior openings thoroughly with exterior caulk.

Vent Piping Installation

⚠WARNING

Every joint on polypropylene vent piping must include a locking collar. Failure to supply locking collars can cause vent or air piping leakage, which can result in severe personal injury, death, or substantial property damage.

⚠WARNING

Use sweep elbows for all vent and air piping. DO NOT use short-radius elbows for vent or air piping. Failure to comply can result in severe personal injury, death, or substantial property damage.

See [Figure 22, page 36](#) for maximum length reductions required.

1. The concentric termination must be assembled and installed before piping from the boiler to the termination. See the previous section and the kit for instructions.
2. Install a vent adapter or reducer if needed. Follow instructions from the vent manufacturer.
3. Install vent and air piping between the boiler and the concentric vent or air termination. Slope vent piping toward the boiler a minimum of 1/4" per foot in horizontal runs, or larger slopes per vent pipe manufacturer's instructions.
4. Support piping independently of the boiler. Install pipe supports every 5 ft. on both the horizontal and vertical runs. Install a hanger support within 6" of any upturn in the piping.

DIRECT VENT — Sidewall Vent and Air Plate (Category IV)

Determine Termination Location

The vent and air plates must be installed as shown in [Figure 50, page 60](#). The termination placement must comply with clearances and limitations shown in [Figure 36, page 49](#).

1. Install the termination in a location where damage from foreign objects and buildup of leaves or sediment is unlikely.
2. Ensure proper clearance above grade or snow line. Keep vents and air area clear of accumulating snow.
3. Install the boiler in a location that allows proper routing of all vent piping from the boiler vent connection to the selected sidewall location.

WARNING

Locate the termination such that the total vent piping from the boiler to the termination will not exceed the maximum length given in [Figure 22, page 36](#) for Category IV venting. Failure to comply can result in severe personal injury, death, or substantial property damage.

IMPORTANT

Read and follow all instructions in this manual. Do not proceed with vent installation until you have read [pages 29-40 & 49](#). Comply with all vent system manufacturer's instructions.

Multiple Vent Terminations

When terminating multiple SVF boilers, terminate each vent and air connection as described in this manual. See [Figure 48](#) for adjacent termination clearances.

WARNING

All vent and air inlet pipes must terminate at the same height to prevent severe personal injury, death, or substantial property damage.

WARNING

For terminations of other appliances, provide at least the clearance shown. The installation for other appliances must also comply with this manual. Failure to comply can result in severe personal injury, death, or substantial property damage.

Figure 47 Sidewall direct vent terminations – vent and air plate

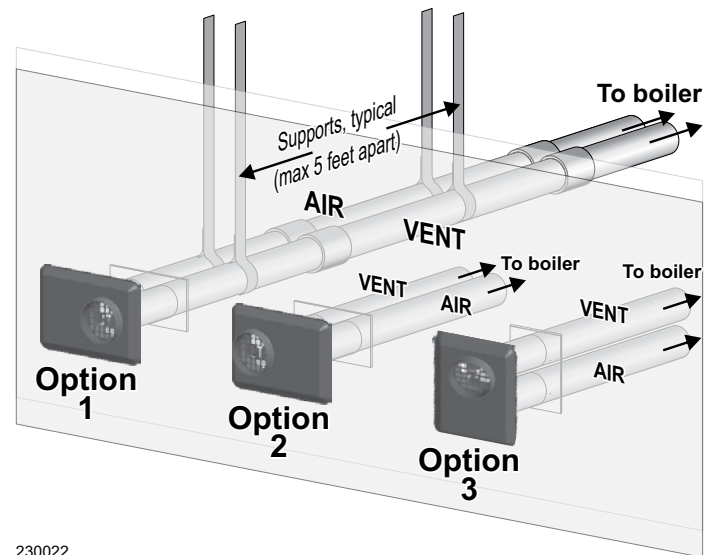

230022

Figure 48 Adjacent terminations, vent and air plates – clearance from air inlet to exhaust

12" minimum between edge of vent opening and adjacent termination

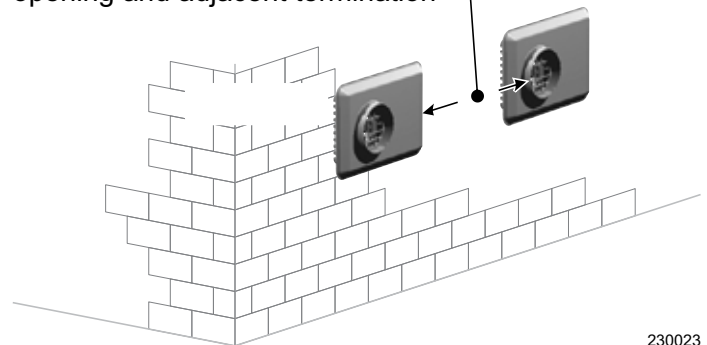

230023

- For U.S. installations, place wall penetrations to obtain minimum clearances shown in [Figure 48](#) and [Figure 36, page 49](#).
- In Canada, provide clearances required by the Installation Code – CAN/CSA B149.1 or B149.2. Use a ULC S636-compliant vent kit.
- The air inlet of a boiler is part of a direct vent connection. It is not classified as a forced air intake with regard to spacing from adjacent boiler vents.

Vent and Air Plate Installation

⚠ WARNING

For the Weil-McLain plate, the template must be level to ensure the flue and air pipe will be side-to-side, as shown in Figure 49. Failure to comply can result in severe personal injury, death, or substantial property damage.

IMPORTANT

The inside and outside cover plates are stamped to identify the exhaust (vent) and intake (air) openings. Make sure to orient the plates correctly.

IMPORTANT

Vent and air pipes and the W-M vent and air plate can be oriented in any of the configurations shown in Figure 47, page 58.

Figure 49 Wall hole preparation (inside view) – use provided template

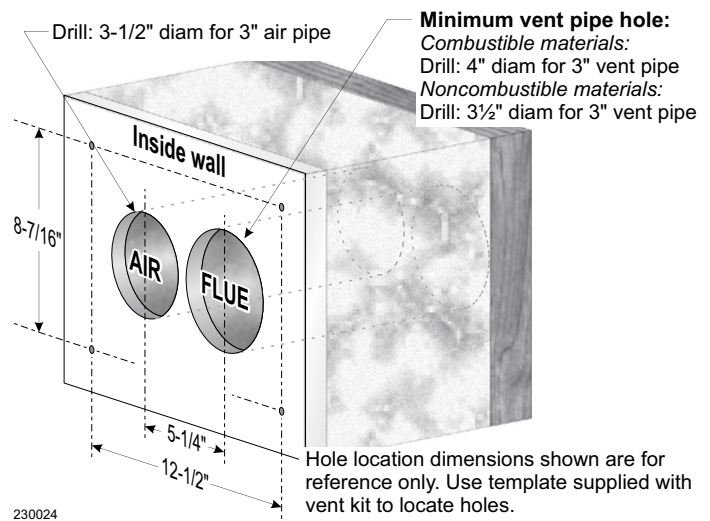

1. Inside wall
2. Drill: 3-1/2" diameter for 3" air pipe; locate using provided template.
3. For combustible materials: drill 4" diameter for 3" vent pipe
For noncombustible materials: drill 3-1/2" diameter for 3" vent pipe
Locate opening using provided template.
4. Drill mounting screw holes using provided template.

1. Locate the termination opening and avoid obstructions. Use the template supplied with the termination kit.
 - a. Place the template on the outside building surface at the penetration location.
 - b. Make sure there are no obstructions that might prevent proper placement of the termination.
 - c. Use the template to mark the locations for the four mounting holes, flue pipe, and air pipe. Level the template with a level.
 - d. Cut holes in the wall as shown in Figure 49, using the location marks made with the template. For best results, use a small-diameter, long drill bit to drill centering holes for the flue and air pipe openings. Then drill the large openings from both the inside and outside.
 - e. The flue pipe and air pipe may be run through a rectangular cutout (as marked on the template) in lieu of two separate holes if desired.
2. Drill holes for the screws or plastic anchors to secure the outside plate. Install the outside plate and mount the termination on the plate (temporarily).
 - a. Cut the flue pipe so the extension through the wall will cause the vent pipe to fully extend into the termination socket.
 - b. Cut the air pipe so the extension through the wall will press the air pipe against the stops inside the termination.
 - c. Temporarily slide the flue and air pipes through the openings. Slide the inside wall plate over the two pipes and into position on the inside wall.
 - d. Position the inside plate so the flue pipe and air pipe slope downward slightly toward the boiler (1/4" per foot).
 - e. Mark the four mounting holes for the plate.
 - f. Remove the vent and air pipe, drill the four mounting holes, and mount the inside plate.

DIRECT VENT — Sidewall Vent and Air Plate (Category IV), continued

Vent and Air Plate Installation, continued

3. Test fit the vent/air termination on the vent pipe. Make sure the vent pipe fully penetrates the termination socket and the air pipe butts against the interior stops.
4. Apply silicon RTV sealant to the interior of the vent termination and slide onto vent pipe. Rotate slightly to spread the silicon to ensure a tight seal around the vent pipe.
5. Secure the termination in place using the four (4) #10 x 1/2" sheet metal screws and lock washers. See Figure 50.
6. Seal exterior openings thoroughly with exterior caulk.

Vent Piping Installation

⚠WARNING

Use only the vent materials and kits listed in Table 9, page 33. Failure to comply can result in severe personal injury, death, or substantial property damage.

⚠WARNING

Every joint on polypropylene vent piping must include a locking collar. Failure to supply locking collars can cause vent or air piping leakage, which can result in severe personal injury, death, or substantial property damage.

⚠WARNING

Use sweep elbows for all vent and air piping. DO NOT use short-radius elbows for vent or air piping. Failure to comply can result in severe personal injury, death, or substantial property damage.

See [Figure 22, page 36](#) for maximum length reductions required.

1. Prepare the sidewall penetrations and secure the sidewall plates. See the previous section for instructions.
2. The plate termination must be installed before piping from the boiler to the termination. See [page 59](#) for instructions.
3. Install a vent adapter or reducer if needed. Follow instructions from the vent manufacturer.

Figure 50 Plate termination assembly (inside view)

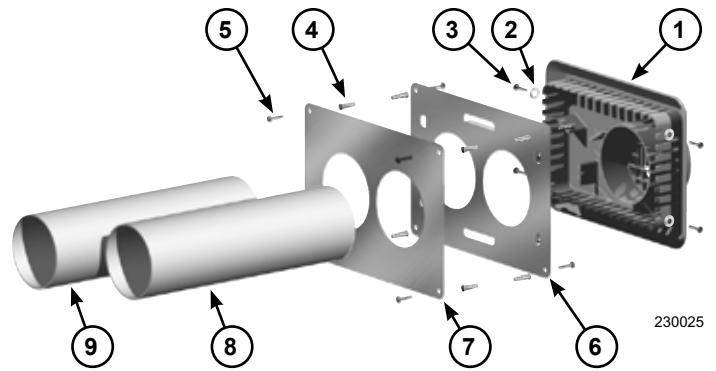

1. Vent termination, 3"	6. Outer mounting plate
2. Lock washer, #10 (4)	7. Inner mounting plate
3. Sheet metal screw, #10 x 1/2" (4)	8. Vent pipe – abut to screen in termination
4. Plastic wall anchor (8)	9. Air pipe – abut to stops in the termination
5. Sheet metal screw, #10 x 1-1/4" (8)	

4. Install vent and air piping between the boiler and the vent/air termination plate. Slope vent piping toward the boiler a minimum of 1/4" per foot in horizontal runs or larger per vent pipe manufacturer's instructions.
5. Support piping independently of the boiler. Install pipe supports every 5 ft. on both the horizontal and vertical runs. Install a hanger support within 6" of any upturn in the piping.

Install Condensate Components

Condensate Trap Installation

⚠ WARNING

The condensate trap must be in a vertical orientation and not wedged against the ground or any other object. If the trap is installed incorrectly, flue gas could leave through the condensate drain, which can result in severe personal injury or death.

1. Slide the end of the plastic condensate trap onto the drain on the back side of the boiler.
2. Tighten a hose clamp to secure the condensate trap to the drain pipe.
3. Secure the condensate bracket to the boiler base.
4. Slide the PVC tee through the bracket.
5. Ensure the second hose clamp is loosely installed over the right side of the trap. Slide the trap over the tee and up to the bracket. Slide the hose clamp up to the bracket and tighten.

Condensate Line Connection

1. Use 3/4" PVC or CPVC pipe to route condensate to a drain or condensate pump.
2. If installing a condensate pump, select one approved for use with condensing boilers and furnaces. The pump should have an over-flow switch to prevent property damage from spillage. Provide an external power source for the pump.
3. Minimum recommended condensate pump capacity in gallons per hour per boiler:
 - SVF 500, 10 GPH
 - SVF 600, 10 GPH
4. When sizing condensate pumps, make sure to include the total load of all SVF boilers connected.

NOTICE

The condensate line must remain unobstructed, allowing free flow of condensate. If condensate freezes or the line is obstructed, condensate can back up into the boiler, leading to boiler lockout.

IMPORTANT

Condensate from the boiler will be slightly acidic, typically 3.2 to 4.5 pH. Install a neutralizing filter if required by local codes. See the Parts section starting on [page 131](#) for a Weil-McLain condensate neutralizer kit.

Figure 51 Condensate trap assembly components

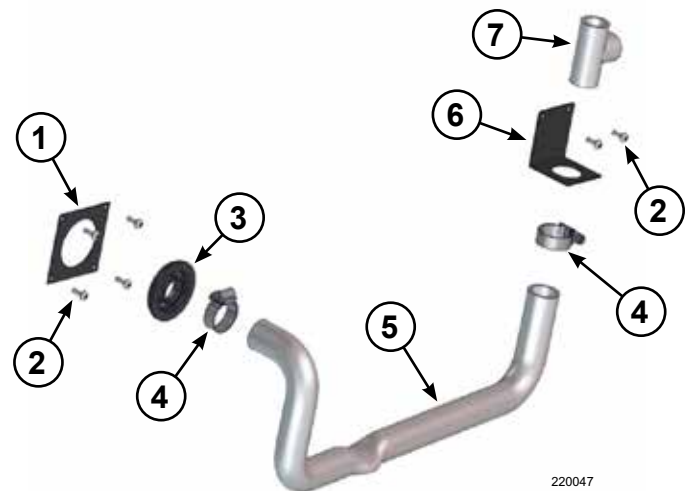

- | | |
|--------------------------|-----------------------|
| 1. Condensate Line Panel | 5. Condensate Trap |
| 2. #10 Torx Screw | 6. Condensate Bracket |
| 3. 3/4" Grommet | 7. 1/2" PVC Tee |
| 4. Hose Clamp | |

Figure 52 Condensate trap assembly, installed



NOTICE

Use materials approved by the authority having jurisdiction. In the absence of other authority, PVC and CPVC pipe must comply with ASTM D1785, F441, or D2665. Cement and primer must comply with ASTM D2564 or F493. For Canada, use CSA or ULC certified PVC or CPVC pipe, fittings, and cement.

Gas Piping

Gas Supply Piping Connection

⚠WARNING

Use two wrenches when tightening gas piping at the boiler. Use one wrench to prevent the boiler gas line connection from turning. Failure to prevent the boiler gas connection pipe from turning could damage gas line components, which can result in severe personal injury, death, or substantial property damage.

1. Connect the gas supply piping to the boiler. See Figure 53.
 - a. Install a union for servicing when required.
 - b. Install a manual gas shut-off valve in the gas supply piping within 6 ft. of the boiler.
 - c. In Canada, the manual gas shut-off valve must be identified by the installer.
2. Support gas piping with hangers or other devices. Do not support the piping by the boiler or boiler accessories.
3. Use pipe dope compatible with propane gases as natural gas may contain some propane. Apply pipe dope sparingly only to male threads of pipe joints so that it does not block gas flow.

⚠WARNING

Apply pipe dope as detailed in this section. Failure to apply pipe dope properly can result in severe personal injury, death, or substantial property damage.

⚠WARNING

SVF boilers are shipped ready to fire natural gas ONLY. The propane conversion kit must be installed if the boiler will be connected to propane. See [page 16](#) for instructions. Failure to comply can result in severe personal injury, death, or substantial property damage.

4. If any factory installed gas connections are altered during installation, make sure to check for leaks before operation. See [page 63](#) for more information on checking for leaks.

Figure 53 Gas supply piping connection (fittings and gas valve supplied by installer)



5. If inlet pressure can exceed 14" W.C. at any time:
 - a. Install a 100% lock up gas pressure regulator as defined by ANSI Z21.80 in the gas supply line. Lock up regulators can have pressure spikes of 5" W.C. or 150% of setting, whichever is greater.
 - b. Adjust the lock up regulator for inlet pressure below 10" W.C. with the boiler at minimum input rate. This setting provides a cushion below the setting of the high gas pressure switch.
 - c. Gas pressure can be adjusted higher or lower as needed.

⚠WARNING

A lock up regulator must be installed as detailed if inlet pressure can exceed 14" W.C. Failure to comply can result in severe personal injury, death, or substantial property damage.

230109

Check Natural or LP Gas Supply Pressure

1. Purge all air from the gas supply piping.
2. Check the boiler and its gas connection for leaks before placing the boiler in operation.
 - a. Close manual main shut-off valve during any pressure testing at less than 14" W.C.
 - b. Disconnect the boiler gas connection from the gas supply piping during any pressure testing greater than 14" W.C.

WARNING

DO NOT check for gas leaks with an open flame; Gas leaks can result in an explosive atmosphere Use a soapy water bubble test to check for gas leaks. Failure to follow these instructions can result in severe personal injury, death, or substantial property damage.

3. Connect a manometer or pressure gauge to the tapping on the gas line elbow by the gas valve. See Figure 54.
4. Verify minimum gas pressure when all gas appliances are in operation. The pressure at the gas valve test port is as follows:
 - a. Minimum gas pressure required with gas flowing is 3.5" W.C. Verify during boiler startup while boiler is at high fire.
 - b. Maximum gas pressure is certified to 14" W.C., whether the boiler is running or turned off. See [page 62](#) for installation of a 100% lock up regulator as necessary

Gas Train Diagram

Figure 55 Gas train diagram

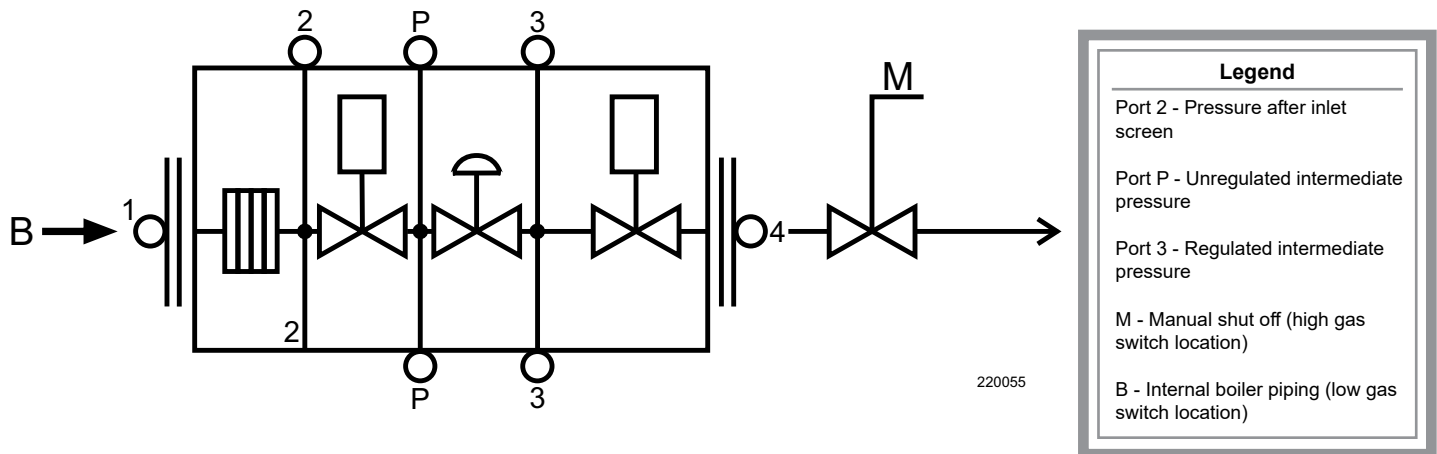
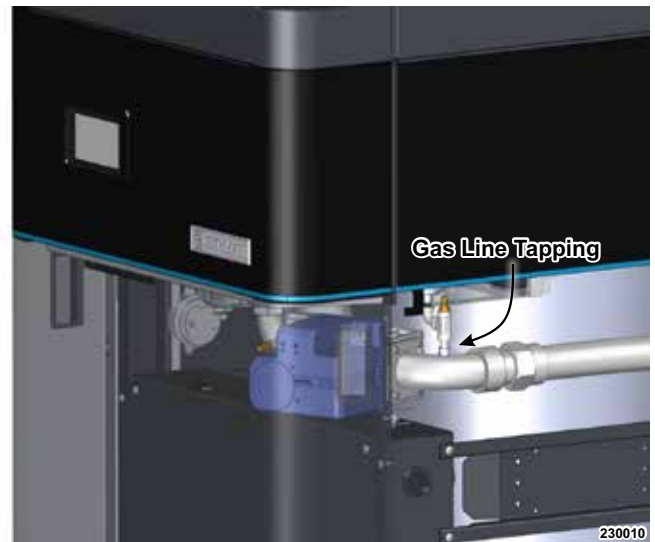

Figure 54 Gas line tapping



Gas Piping, continued

Pipe Sizing for Natural Gas

1. Size gas supply piping from meter outlet to the entrance of the boiler in accordance with Table 11 and Table 12.
2. Divide the total input in Btuh of all connected appliances by 1,000 to obtain approximate cubic feet per hour of natural gas.
 - a. Pipe lengths in Table 11 are equivalent lengths of straight pipe. Use Table 12 to determine equivalent length of fittings. Add the total straight pipe with the equivalent lengths of the fittings to determine the gas pipe total length.
 - b. Table 11 is only for natural gas with specific gravity 0.60, with a pressure drop through the gas piping of 0.30" W.C.
3. Gas pipe must be properly sized with a 100% lock up gas pressure regulator in the gas supply line.
4. For additional gas pipe sizing information, refer to ANSI Z223.1/NFPA 54, latest edition. In Canada, refer to the National Gas and Propane Installation Code – CAN/CSA B149.1.

Pipe Sizing for Propane Gas

Ensure the boiler is converted to propane per instructions on [page 16](#). Contact the gas supplier to size pipes, tanks, and 100% lock up gas pressure regulators. Gas pipe must be properly sized with a 100% lock up gas pressure regulator in the gas supply line. An undersized gas pipe feeding the boiler can cause issues.

Multiple Boiler Applications - Manifolder Gas Supply Lines

1. Size the gas supply piping as instructed above.
2. Provide a manual shutoff gas valve, union, and sediment trap (minimum 3" below tee) at each boiler as shown in [Figure 53, page 62](#).
3. Ensure the piping is large enough to meet the minimum pressure requirement at each boiler as specified on [page 63](#).

Table 11 Pipe capacity for natural gas

Gas Pipe Total Length (ft.)	Gas Supply Pipe Capacity (cubic feet per hour) @ 0.30" W.C. pressure drop (cubic feet per hour, 0.60 specific gravity)			
	2"	2.5"	3"	4"
10	3050	4800	8500	17500
20	2100	3300	5900	12000
30	1650	2700	4700	9700
40	1450	2300	4100	8300
50	1270	2000	3600	7400
70	1050	1700	3000	6200
100	870	1400	2500	5100
150	710	1130	2000	4100

Table 12 Equivalent lengths for gas line fittings

Pipe Size	Equivalent Length (ft.)	
	90° Elbow	Tee
2"	5.17	10.30
2.5"	6.16	12.30
3"	7.67	15.30
4"	10.10	20.20

Gas Pressure Switches

SVF boilers are equipped with high and low gas pressure switches. A fault will occur if either switch is activated and will need to be reset at the control.

1. The low gas pressure switch will automatically reset after control reset.
2. After control reset, the high gas pressure switch will need to be manually reset. A red light will be illuminated on the switch, indicating a need for manual reset.

The control will show the same gas pressure fault regardless of which switch is activated. If no light is illuminated on the high gas pressure switch, the low gas pressure switch caused the fault.

High gas pressure switch: 1" W.C.

Low gas pressure switch: 2" W.C.

SECTION 3

Electrical

This section is intended to provide wiring and zoning instructions for qualified installers and service contractors.

Section Contents

Electrical – General.	65
Field Wiring.	66
Zoning with the Control.	80

Electrical – General

⚠ WARNING

Turn off electrical power supply at the service entrance panel before making any electrical connections. Failure to turn off the electrical power can cause electric shock, which can result in severe personal injury or death.

NOTICE

Do not use 24V from a transformer to power any external devices that are not listed in this manual.

The installation must comply with the National Electrical Code and any other national, state, provincial, or local codes and regulations. In Canada, comply with Canadian Electrical Code, Part 1 – CSA C22.1, and any other local codes.

⚠ WARNING

Wiring errors can cause improper and dangerous operation. Label all wires to ensure proper connection. Never jumper (bypass) any device except for momentary testing. Failure to comply can result in severe personal injury, death, or substantial property damage.

Wiring must be N.E.C. Class 1. If original wiring supplied with the boiler must be replaced, use only type 105°C wire or equivalent. The boiler must be electrically grounded as required by the National Electrical Code – ANSI/NFPA 70, latest edition, or the Canadian Electrical Code, Part 1 – CSA C22.1.

The boiler must be electrically bonded to ground when installed in accordance with the requirements of the authority having jurisdiction. In the absence of such requirements, comply with the requirements in the National Electrical Code – ANSI/NFPA 70, latest edition, or the Canadian Electrical Code, Part 1 – CSA C22.1.

Seal all electrical entrances. Use a sealed strain relief, or a strain relief sealed with duct seal putty or silicone. Sealing the entrances prevents the boiler from drawing air from inside the boiler room; this is particularly important if the boiler is located in the same room as other gas appliances.

⚠ WARNING

All electrical entrances must be sealed. Unsealed entrances can draw air from inside the room, which can result in severe personal injury, death, or substantial property damage.

Power Requirements

- The SVF 500/600 boilers are manufactured for 120 Vac, 60 Hz electrical service.
- The total operating amperage of the boiler is dictated by the boiler max draw (6A) plus 2.2A per circulator. Maximum total draw is 17 amps. Boiler total draw cannot exceed 80% of the breaker amperage. Size the external disconnect accordingly.
- Before starting the boiler, ensure the proper electrical service is connected to the boiler.
- An external electrical disconnect and overload protection (not supplied with the boiler) **are required**.
- The installed conduit must not block any of the boiler's openings, and it must allow space to open the front door.



Field Wiring

Terminal Connections

All low voltage field wiring is made directly to the corresponding terminal blocks on the circuit board.

Low voltage, 24 Vac terminals are on the right side and right bottom of the circuit board.

Line voltage, pump, and AUX, 120 Vac, terminal strips are inside the control tray on the left side of the boiler.

Wiring Overview

See details on the following pages for the wiring connections outlined below.

1. Required wiring connections:
 - a. 120 Vac power to the boiler.
 - b. 120 Vac power out to the boiler circulator.
 - c. System supply and return temperature sensors.
2. Connections as needed by systems:
 - a. Thermostat, end switch, or other inputs for call for heat.
 - b. System zone circulators, valves, relays, and other similar connections.
 - c. System circulator, when required.
 - d. Outdoor Temperature Sensor (ODT).
3. Optional wiring connections:
 - a. External limits, proof-of-closure interlocks (combustion air damper, flow switch, etc.), 0–10 Vdc for target or modulation control, remote alarm, additional heat demand contact, communication cables for building management system interface (Modbus sold separately), multi-boiler wiring, isolation/bypass valves, and a variable speed pump.

Wire Entrances

⚠ WARNING

A strain relief must be used through jacket knockouts. Failure to comply can result in severe personal injury, death, or substantial property damage.

Wire entrance knockouts are provided on the right, back, and left of the boiler cabinet.

See the figures on [page 67](#) for knockout locations.

1. Line voltage – three knockouts on the left of the cabinet, and three knockouts on the back (Line In, Outputs 1, 2, 3, 4).
2. Low voltage – three knockouts on the right of the cabinet and three knockouts on the back. Use one of these six knockouts for BMS communication wiring.
3. Seal all electrical entrances. Use a sealed strain relief, or a strain relief sealed with duct seal putty or silicone.

⚠ WARNING

All electrical entrances must be sealed to prevent the boiler from drawing air from inside the boiler room. Failure to seal entrances can result in severe personal injury, death, or substantial property damage.

Wire Routing in the Cabinet

1. Line voltage: (120 Vac in, circulator outputs)
 - a. Line voltage should be wired from the left side electrical entrances going into the control tray.
 - b. Strip end of wire no more than 1/4" to avoid exposing uninsulated wire.
 - c. It is recommended to install an On/Off service switch in a junction box mounted near the boiler. Installation must meet all National and local electrical codes.
2. Low voltage:
 - a. Mount low voltage wire grommet(s) to desired low voltage knockout(s).
 - b. Thermostat, aquastat, limit devices, system sensors, 0-10 Vdc input/output, and outdoor temperature sensor wire pairs should be routed through the grommets and knockouts.
 - c. Wires should be connected directly into the corresponding terminal block.
 - d. Bundle all wires together with provided wire ties. Loop wire tie with bundled wires through wire tie mount and secure mount to control bracket in bottom right mounting hole.
 - e. After wires and connectors are attached to the control terminal blocks, make sure wires are properly sealed in the cabinet electrical entrances.

Figure 56 Boiler front knockouts

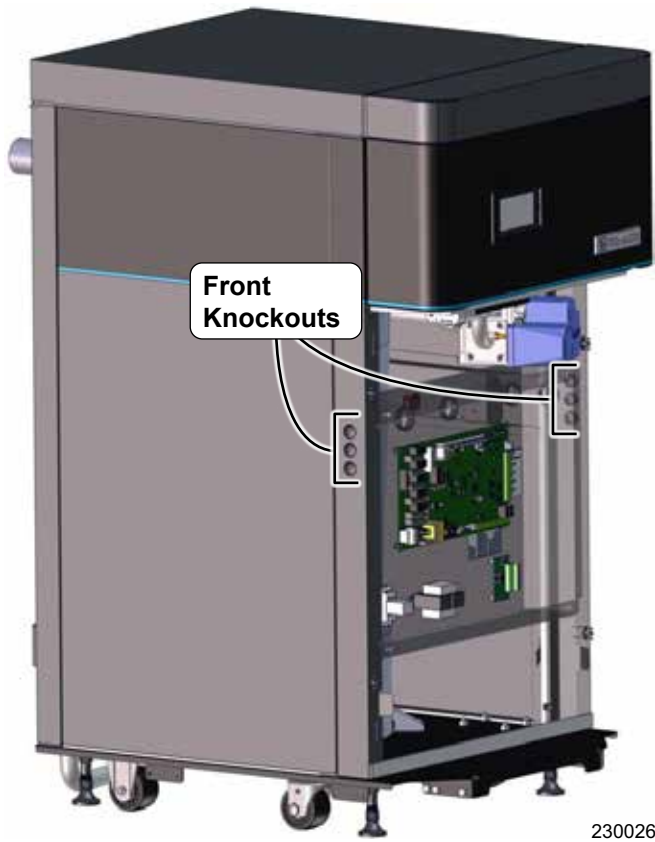

Figure 57 Boiler back knockouts



3

Field Wiring, continued

Schematic Diagram

Figure 58 Schematic wiring diagram for SVF 500/600 boilers (continued on the next page)

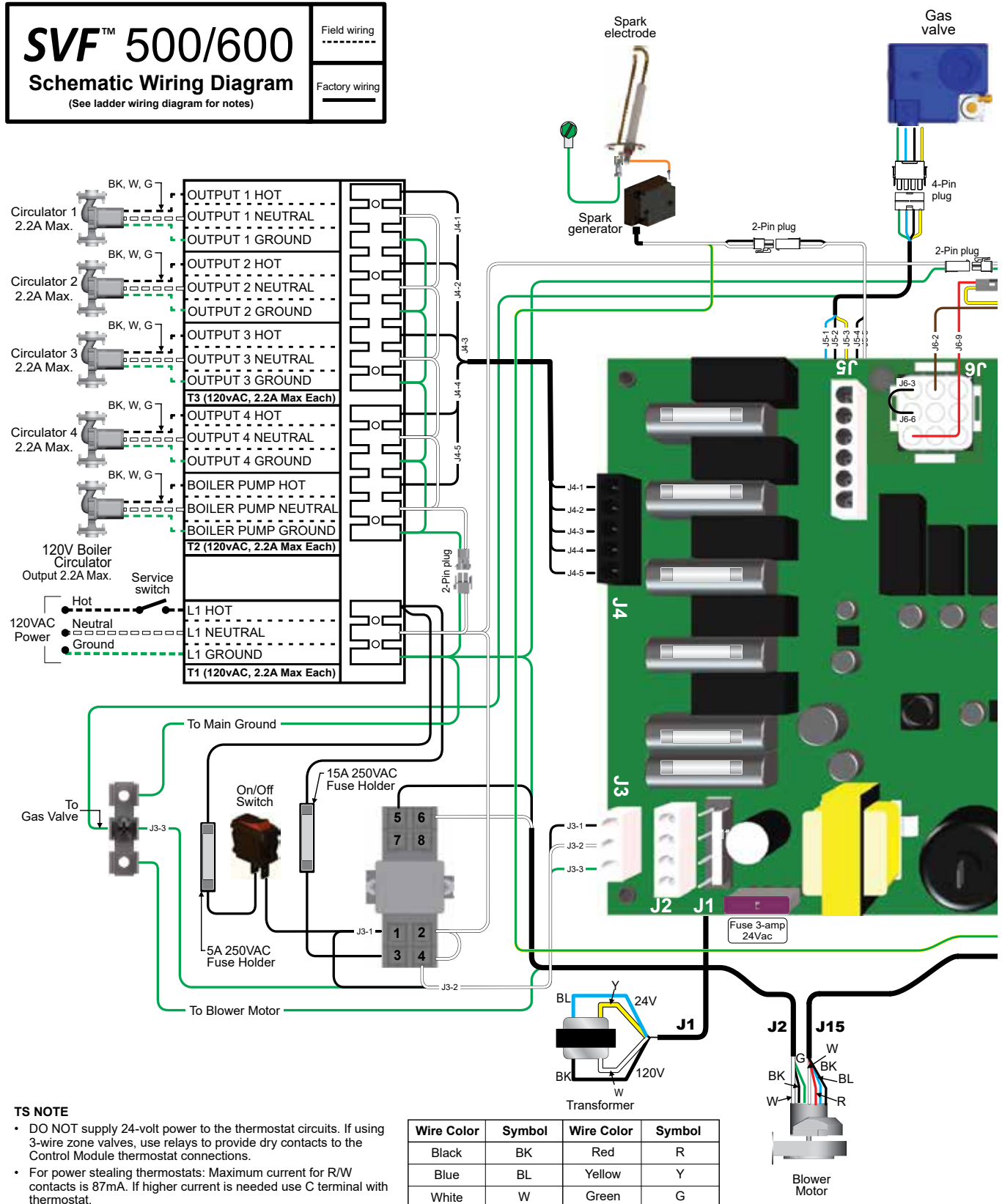

3



Schematic Diagram, continued

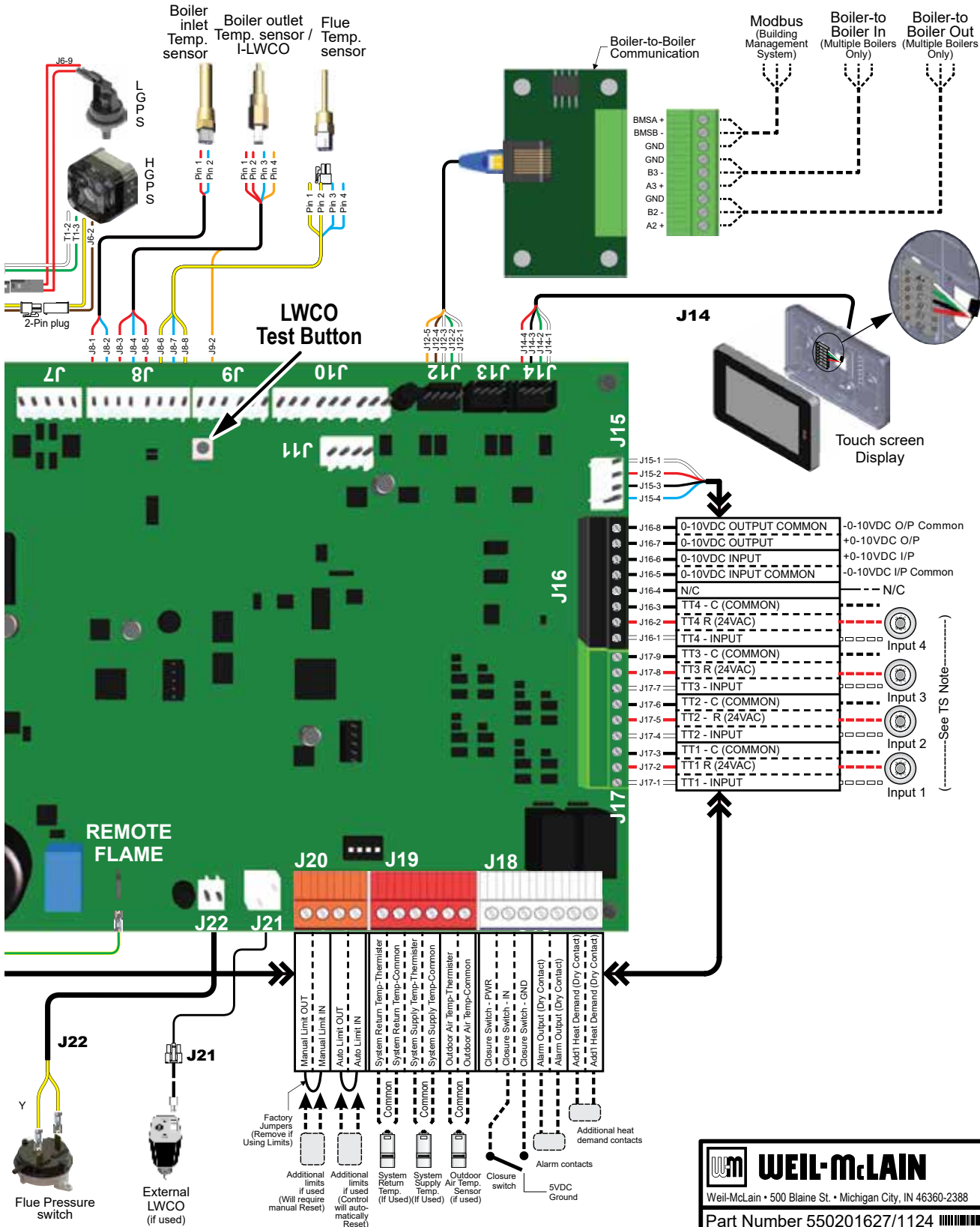

WEIL-McLAIN
 Weil-McLain • 500 Blaine St. • Michigan City, IN 46360-2388
 Part Number 550201627/1124



3

Field Wiring, continued

Ladder Diagram

Figure 59 Ladder wiring diagram for SVF 500/600 boilers (continued on the next page)

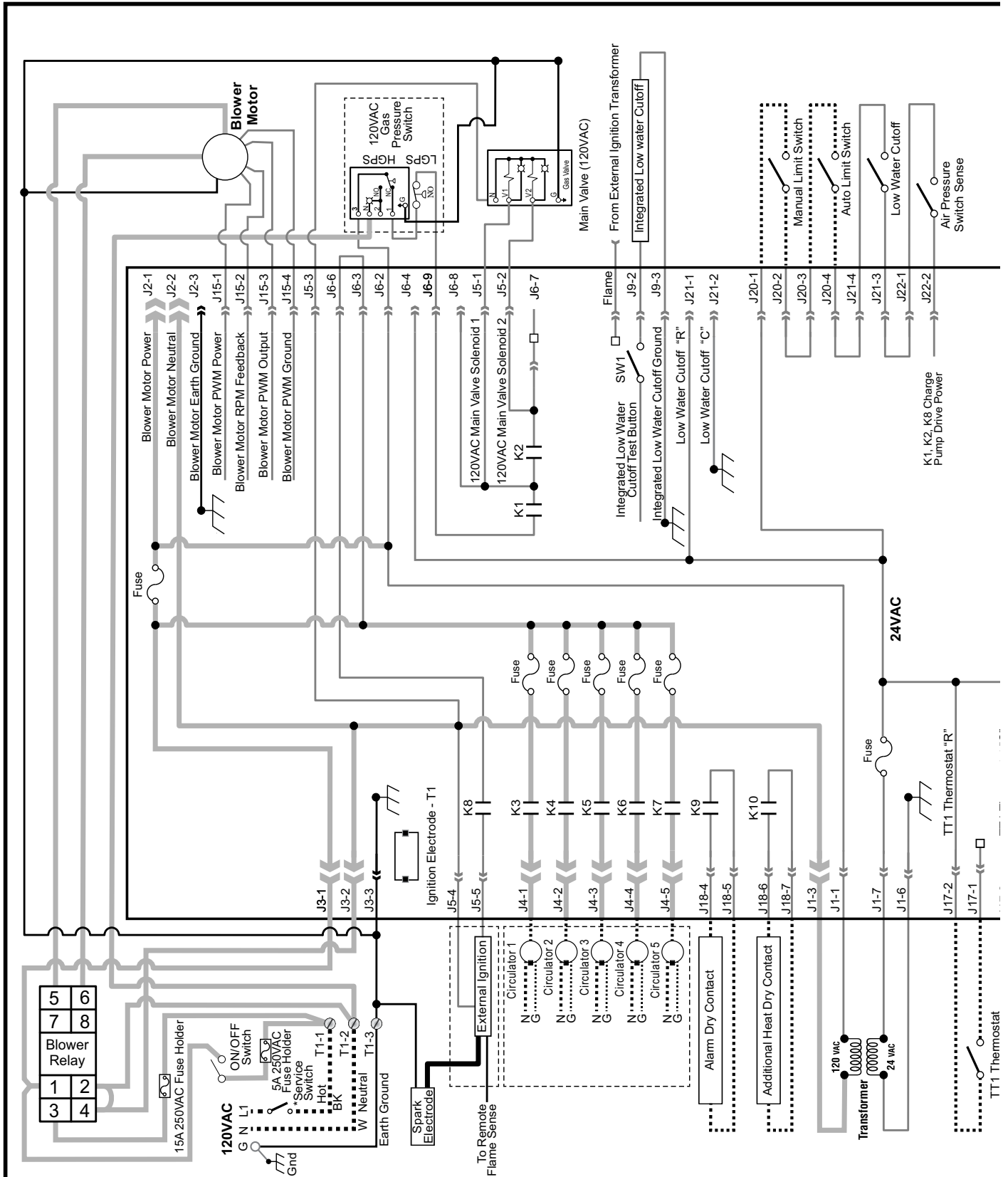

Ladder Diagram, continued

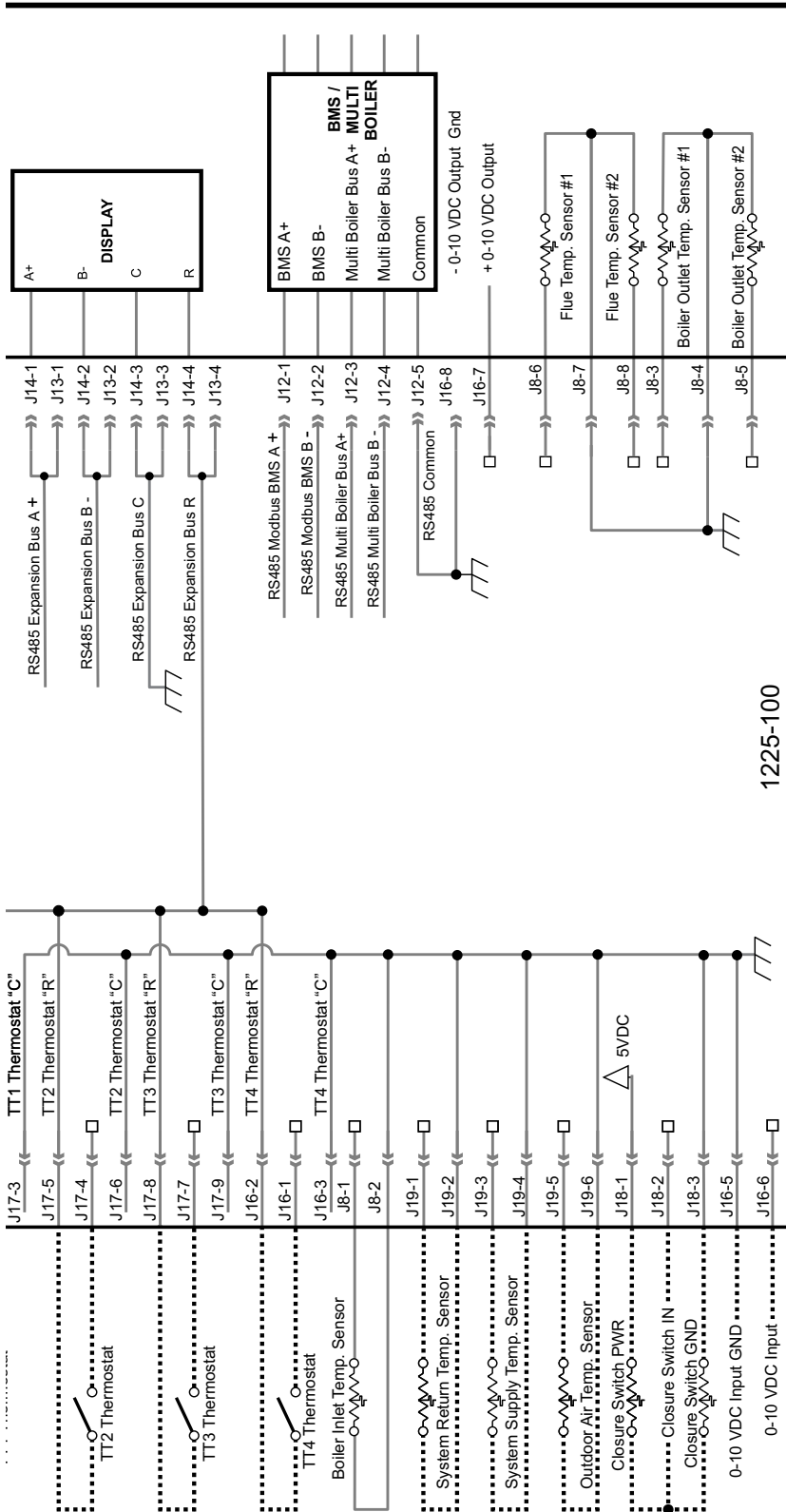

SVF™ 500/600

Ladder Wiring Diagram



Electrical shock hazard — can cause severe injury or death. Disconnect power before installing or servicing.

NOTICE

- All contacts shown without power applied.
- * Items not provided.

NOTES (for Schematic and Ladder Diagrams)

1. All wiring must be installed in accordance with:
U.S.A. — NEC ANSI/NFPA 70 - latest edition and any other national, state, or local code requirements.
Canada — CSA C22.1 C.E.C. Part 1 and any other national, provincial, or local code requirements.
2. Connect additional limits (if used) between terminals J20-1 and J20-2 if the boiler circuit board is to manual reset on limit action. Connect between terminals J20-3 and J20-4 for automatic reset. Remove jumper across terminals used.
3. If any of the original wire as supplied with the appliance must be replaced, use minimum 105° C wire or equivalent. Exceptions: Ignition lead wire, ignition ground wire, and flame sense wire must be replaced only with Weil-McLain parts.
4. Thermostat anticipator setting (single zone) — set anticipator for 0.1 amps.
5. For multiple zoning, use either zone valves or circulators. Refer to the component manufacturer's instructions and the manual for application and wiring suggestions.
6. Refer to control component instructions packed with the boiler for application information.
7. To field wire a non-powered (isolated contact) low water cutoff, clip the factory jumper in the factory-installed Molex plug, strip the wires, and connect to the low water cutoff limit terminals.

Legend for ladder wiring diagram only

- 120VAC field wiring
- Low voltage field wiring
- Field ground connectors
- 120VAC factory wiring
- Low voltage factory wiring
- High voltage spark ignition wiring
- Ground connectors



Weil-McLain • 500 Blaine St. • Michigan City, IN 46360-2388

Part Number 550201629/0523



Field Wiring, continued

Terminal Block Wiring

A. 120 Vac Power Supply — REQUIRED

Terminal Strip T1

1. Provide and install a properly-sized, fused disconnect or service switch as required by applicable codes.
2. Use the table at the right to determine the total load.
3. Connect properly sized 120 Vac power wiring to the boiler line voltage terminal block T1.
4. If possible, provide a surge suppressor in the supply power line. This will reduce the possibilities of control damage due to line surges.

⚠ WARNING

Wire ground to this terminal to provide boiler grounding. Failure to properly ground the boiler can result in severe personal injury, death, or substantial property damage.

Determine Total Load	
Boiler	<u>6</u> amps
120V Boiler Pump (2.2 amps max)	_____ amps
Output 1 (2.2 amps max)	_____ amps
Output 2 (2.2 amps max)	_____ amps
Output 3 (2.2 amps max)	_____ amps
Output 4 (2.2 amps max)	_____ amps
TOTAL	_____ amps

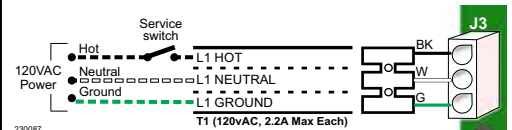

B. 120 Vac Outputs 1, 2, 3, and 4 – As needed for systems

Terminal Strips T2 and T3

- Output 1: T2 – 4, 5, & 6
- Output 2: T2 – 7, 8, & 9
- Output 3: T3 – 10, 11, & 12
- Output 4: T3 – 13, 14, & 15

1. Maximum load: 2.2 amps. Use a relay if circulator load is higher.

⚠ WARNING

The maximum allowable current for each circulator is 2.2 amps at 120 Vac. For circulators with higher amp ratings, install a circulator relay or starter. Connect only the 120 Vac coil to the circulator terminals. Failure to comply can result in severe injury, death, or substantial property damage.

2. These four outputs can provide 120 Vac to the following:
 - a. A zone circulator.
 - b. A system circulator.
 - c. A DHW circulator (used to circulate through an indirect tank).
 - d. An auxiliary item that may be energized during an input call, such as an air damper.
3. When using inputs and outputs for heat or indirect DHW demands, each input (Input 1, Input 2, Input 3, and Input 4) controls its respective 120 Vac output (Output 1, Output 2, Output 3, and Output 4). Outputs are energized only when BOTH conditions below are met:
 - a. The corresponding input indicates a call for heat or indirect DHW with contact closure.
 - b. The PRIORITY assigned to the Input/Output pair is ACTIVE. The zone may call, but the pump does not activate unless the boiler is currently running on that system and priority.
4. When using the inputs/outputs for the AUX PUMP/OUTPUT function, the output is controlled by selectable conditions set up in the control.
 - a. Use the AUX PUMP/OUTPUT function for devices such as system pumps, combustion air dampers, and other auxiliary equipment to activate when the selected condition is met.
 - b. See the Advanced manual (part number 550-100-207) for more information on the setup and selection of operating conditions.

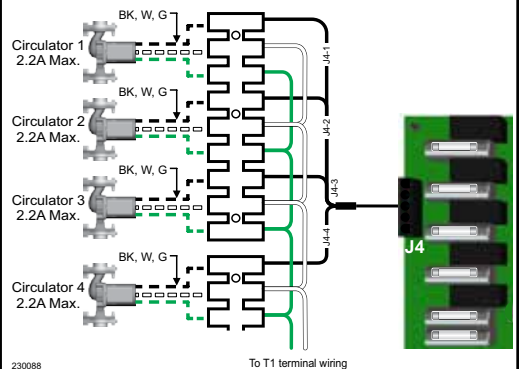

IMPORTANT

For Priority Indirect DHW Application: The DHW aquastat can be connected to any one of the four input and output pairs. The selected input should be assigned to PRIORITY 1 during the Wizard setup or manually in the System Settings menu.

NOTICE

Output circuits are 120 Vac. If an output is to operate a low voltage circuit or must be an isolated contact, use an isolation relay.

C. Inputs 1, 2, 3, and 4 – As needed for systems

Connector J17 (Inputs 1, 2, and 3) and Connector J16 (Input 4, 0-10 Vdc Input, 0-10 Vdc Output)

- Input 1: Connector J17 – 1, 2 & 3 (common)
- Input 2: Connector J17 – 4, 5 & 6 (common)
- Input 3: Connector J17 – 7, 8 & 9 (common)
- Input 4: Connector J16 – 1, 2 & 3 (common)

1. These four inputs on each boiler can indicate a call for heat to the control by means of a dry contact closure (thermostat, aquastat, or switch).
2. The control provides inputs for up to four demands and up to three priorities.

NOTICE

DO NOT supply 24-volt power to the thermostat circuits (Input 1, Input 2, Input 3 and Input 4) or attempt to supply 24 volts for any other application. For thermostats that require a continuous 24-volt power source, connect the common wire (“C”). Do NOT exceed 120mA total amp draw at 24 Vac per thermostat.

IMPORTANT

For Priority Indirect DHW Application: The DHW aquastat can be connected to any one of the four input and output pairs. The selected input should be assigned to PRIORITY 1 during the Wizard setup or manually in the System Settings menu.

3. If using a thermostat anticipator, setting must be set to 0.1 amps.
4. The default control setting uses each input (Input 1, Input 2, Input 3 and input 4) to control its respective 120 Vac output (Output 1, Output 2, Output 3 and Output 4).
5. An input can be assigned to an AUX PUMP/OUTPUT function to operate a system pump or interlock with a combustion air damper. Inputs assigned for this function cannot be used for heat demand operation.
6. Inputs can also be assigned to Primary Valve Control. This disables the input and assigns it's output to activate a bypass or isolation valve.
7. See the Advanced manual for more information on the setup and selection of operating conditions.

TT or end switch inputs (INPUTS 1, 2, 3, 4) with External 0-10 Vdc Inputs

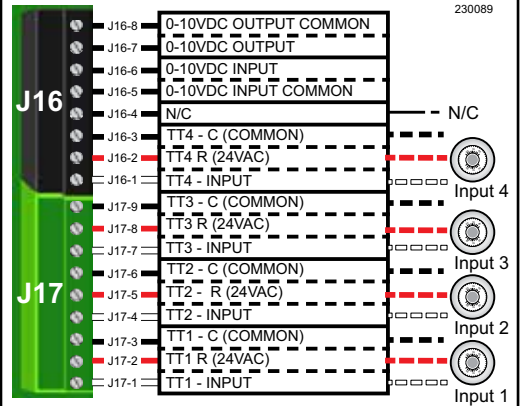

NOTICE

If using 3-wire zone valves, use relays to provide dry contacts to the Control thermostat connections. The zone valve end switches of 3-wire valves carry 24 Vac from the valve.

IMPORTANT

Use of 0–10 Vdc input for modulation disables Input 2 T/T input from creating calls for heat. See Section L on page 77 for instructions.

D. System Supply and Return Temperature Sensors – Required

Connector J19

1. Two (2) immersion temperature sensors are shipped with each boiler Install one to the system supply piping and the other to the system return piping See SVF™ boiler manual replacement parts section for available replacement immersion sensors or strap on sensors.
2. Locate the supply sensor at least six pipe diameters, but no further than 3 feet, downstream from the boiler connection to the main to ensure adequate mixing.
3. Return sensor – wire between J19 #1 and #2.
4. Supply sensor – wire between J19 #3 and #4.
5. Thermostat wire can be used to connect these sensors.
6. The Control compares the system return temperature with the system supply temperature.
7. For more information on single and multiple boiler installations, see the Advanced manual.

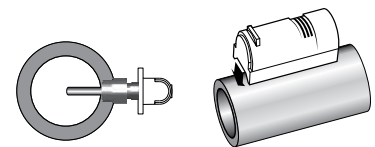

1/2" NPT-4" long Immersion sensors standard. Optional strap on sensors available in Replacement Part section.

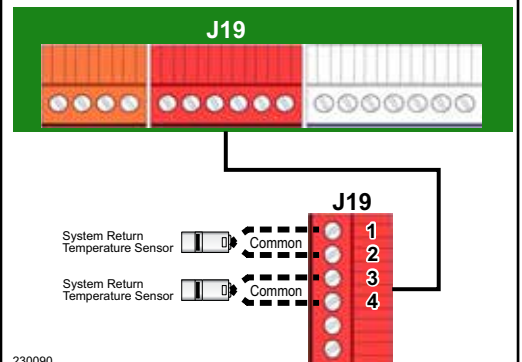

Field Wiring, continued

Terminal Block Wiring, continued

E. Outdoor Temperature (ODT) Sensor – *Optional*

Connector J19

1. The control provides programmable options if using an ODT sensor. This sensor is supplied with the boiler.
2. Mount the ODT sensor on an exterior wall, shielded from direct sunlight and flow of heat or cooling from other sources.
3. The wire outlet on the sensor must be oriented DOWN to prevent water entry.
4. Connect the sensor leads to the terminal shown at right and in [Figure 58](#), page 68. Thermostat wire can be used to connect the sensor.

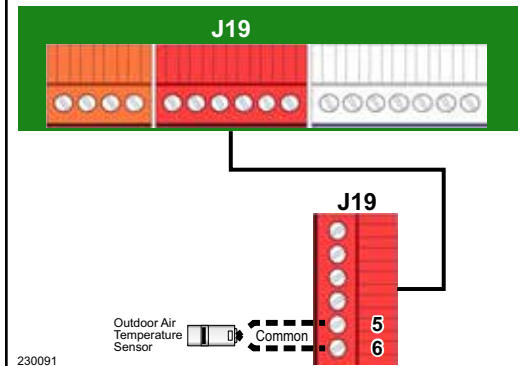

F. External Limits – *Optional*

To cause MANUAL reset: Connector J20 #1 & #2

IMPORTANT

The control will lock out when a limit in its manual reset circuit opens (J20 pins 1 & 2). The control activates its alarm terminals and shuts the boiler down. An operator (user or technician) must manually reset the control to restart the boiler.

- Remove the factory-installed jumper, and connect isolated contacts of external limits across J20 pins 1 and 2. The control will enter manual reset lockout when the limit circuit opens.
- To clear the lockout, the manual limit must be closed. After manual limit is closed, the control must be manually reset on the display. If the user resets the control while the manual limit is still open, the control will remain in lockout, and will create a new instance of the fault.

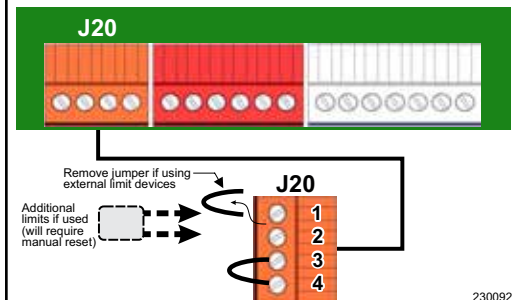

To cause AUTOMATIC reset: Connector J20 #3 & #4

IMPORTANT

The control will reset automatically after circuit is interrupted.

- Remove factory-installed jumper, and connect isolated contacts of external limits across J20 pins 3 and 4. The control will shut down the boiler on limit opening, then automatically restart 150 seconds after the limit closes.

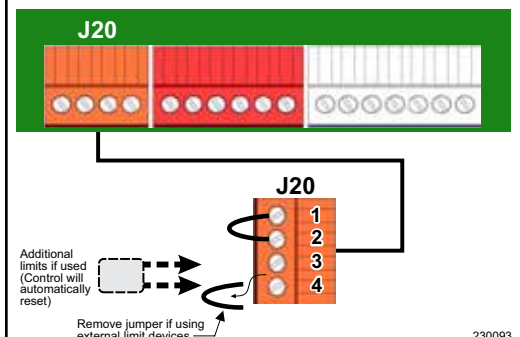

G. Low Water Cut-off (LWCO) – Discrete and Integrated

Connectors J9 and J21

1. An LWCO is integrated in the Boiler Out sensor and connects to J9. See image at right and [page 19](#).
2. A second LWCO can be used in conjunction with the integrated one. See the Miscellaneous Parts section on [page 131](#) for the recommended Weil-McLain part number. Other LWCOs may be used as long as the device uses an isolated contact. This device can be spliced into the jumper installed in J21.

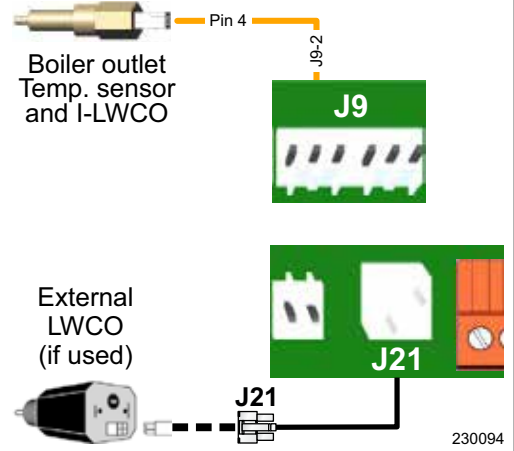

H. Alarm Contacts – Optional

Connectors J18 #4 and #5

1. The control's alarm dry contact (J18, terminals 4 and 5) closes when the boiler enters manual lockout only.
2. Connect these terminals for remote alarm notification.
3. Contact electrical ratings: 24 Vac or less; 0.5 amp or less.

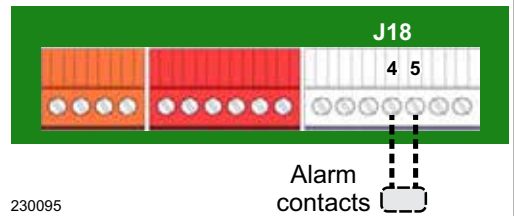

I. Additional Heat Demand Contacts – Optional

Terminal Block J18 #6 and #7

1. The circuit board can be set to activate another heat source using additional heat demand dry contacts through terminal block J18 pins 6 & 7.
2. Connect these terminals to call for heat from the other heat source.
3. Contact electrical ratings: 24 Vac or less; 0.5 amp or less.
4. Set the control to activate the heat demand contacts as needed.
5. For additional heat demand, refer to the Advanced manual for more information.

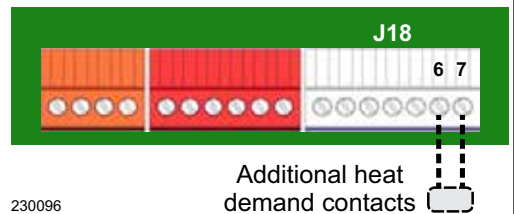

Field Wiring, continued

Terminal Block Wiring, continued

J. Closure Switch – Recommended

Jumper on Connector J18

IMPORTANT

The devices used must provide electrically isolated contacts because the J18 jumper circuit carries 5 Vdc.

- A flow switch or combustion air damper (CAD) interlock can be configured by removing the jumper on connector J18 and wiring components as shown.
- No control settings are required when using a flow switch.
- Recommended configuration of the control for a CAD interlock:
 - Assign INPUT 3 as a AUX PUMP/OUTPUT function.
 - For the AUX PUMP/OUTPUT operating mode, select Local or System Damper for use with CAD Interlock. This ensures the damper will be activated any time the boiler is called on to fire.
 - OUTPUT 3 will provide 120 Vac to the damper motor. Use an isolation relay if damper motor requires another voltage or more than 2.2 amp if using 120 Vac.
 - For multi-boiler wiring of CAD interlock while using a combined system damper installation, wire all Closure Switch inputs in series with the endpoint devices and each boiler's closure switch input.

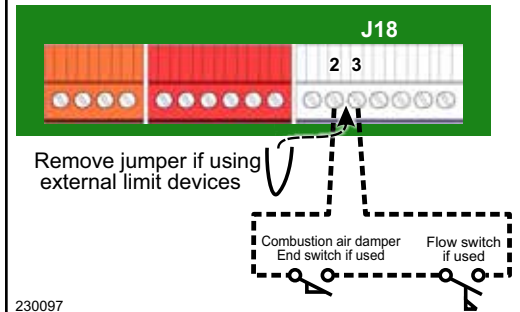

K. 0-10 Vdc Remote Target Input – Optional

Connector J16 #5 and #6

IMPORTANT

The 0–10 Vdc signal replaces the Outdoor Temp sensor as the target temperature modifier (TARGET ADJUST setting). The control does not directly control the target.

- Remote target using 0–10 Vdc input requires a 0–10 Vdc input signal at J16-5/6 as shown at right. The input positive connection must be at J16 terminal 6 and the common connection at terminal 5.
- The illustration at the right shows how to connect TT or end switch contacts at INPUT 1, INPUT 2, INPUT 3 and INPUT 4.
 - If a Heat or Indirect DHW demand is required: Connect the demand's dry contact to an unused input on the control, and its pump/valve to the respective output. Assign and setup a priority to the input using the Wizard or manually through the contractor menu.
 - Apply a dry contact heat demand to one of the inputs to initiate a call for heat.
- The 0–10 Vdc signal is used to adjust the supply target temperature through the TARGET ADJUST setting. Set TARGET ADJUST during the Wizard, or set manually in the Priority Settings menu for the desired priority.
- Many options are available for configuring the control. The following is a suggested setup that uses factory default settings as much as possible.
 - Use PRIORITY 1 for the Indirect DHW heating system when used. This priority's default values are set for Indirect DHW, direct-piped to the boiler. Verify that settings are suitable for the application, and change if needed.
 - Use PRIORITY 2 for the heating systems. The factory default settings for PRIORITY 2 or 3 make either priority a good choice for space heating applications. Set PRIORITY 2 and 3 values to the following:
 - Set TARGET ADJUST value to 0–10V.
 - Set VOLTS FOR MAX TARGET at the voltage that will call for the highest target temperature. Set MAX TARGET TEMP at this temperature.
 - Set VOLTS FOR MIN TARGET at the voltage that will call for the lowest target temperature. Set MIN TARGET TEMP at this temperature.
 - For voltages between VOLTS FOR MAX and VOLTS FOR MIN, the target temperature will range proportionately between MAX TARGET TEMP and MIN TARGET TEMP.

TT or end switch inputs
(INPUTS 1, 2, 3, 4)
with External 0-10 Vdc Inputs

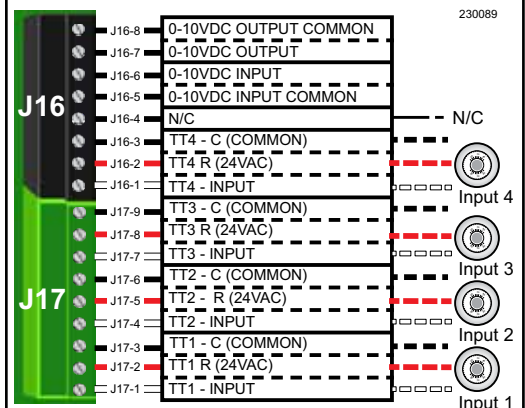

L. 0-10 Vdc Remote Modulation Input – Optional

Connector J16 #5 and #6

IMPORTANT

The control can be configured to use either 0–10 Vdc for target operation (see previous section) or modulation, but not both.

1. The illustration on the right shows how to connect TT or end switch contacts at INPUT 3 and INPUT 4 for other uses.
2. Note that using 0–10 Vdc input replaces INPUT 2 for generating a heat demand. Do NOT wire any input to INPUT 2.
3. Remote modulation requires a 0–10 Vdc input signal at J16-5/6 as shown.
 - a. The 0–10 Vdc input positive connection must be at Terminal 6 and common connection at Terminal 5.
4. Control setup:
 - a. Many options are available for configuring the control. The following is a suggested setup that uses factory default settings as much as possible.
 - b. If Indirect DHW is required, use PRIORITY 2 to minimize setup steps.
 - › Connect the DHW aquastat to INPUT 3 or INPUT 4 and assign the input used to PRIORITY 2.
 - › Verify that control settings are suitable for the application, change if necessary.
 - c. Use PRIORITY 3 for the system to be remote modulated.
 - › Assign INPUT 2 to the priority chosen. Accept all defaults for INPUT 2. No changes should be necessary during the Wizard.
 - › After the Wizard has been completed, go to SYSTEM SETTINGS.
 - › Input Usage menu for INPUT 2. Change SOURCE to 0–10V (default setting is TT1). See the Advanced manual for System Settings menu information.
5. Operation:
 - a. The boiler comes on at 0.9 Vdc and turns off at 0.5 Vdc. 1 Vdc = 10% input. 10 Vdc = 100% input. These voltage settings are not adjustable.
 - b. OUTPUT 2 (120 Vac) is activated and deactivated as the heat demand is turned on and off.

TT or end switch inputs
(INPUTS 1, 3, 4)
0-10 Vdc Inputs

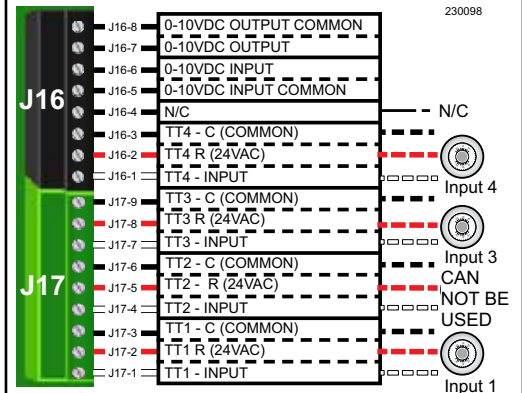

Field Wiring, continued

Terminal Block Wiring, continued

M. 0-10 Vdc Output

Connector J16 #7 and #8

1. Control setup – lead/lag:
 - a. 0–10 Vdc Output functionality allows classic lead/lag system operation, and allows for cooperation with other heat sources that utilize 0-10 Vdc inputs as a source.
 - b. Connect on either Master or Shadow and assign Local 1/Local 2 to use Additional Heat Demand (AHD). For single boiler, connect on any input and assign Priority 1, 2, or 3 to use AHD.
 - c. Adjust MAX RATE VOLTS to desired maximum voltage output. Adjust MIN RATE VOLTS to desired minimum voltage output.
2. Operation – lead/lag:
 - a. The 0–10 Vdc Output only activates when AHD is set to be used, a call for heat that uses AHD is active and Temp Dependent is set to Yes. Valid systems sensors must be present.
 - b. The 0-10 Vdc Output will follow the requested modulation rate, with 10% = Min Rate Volts, and 100% = Max Rate Volts. Voltages between are scaled accordingly.
3. Control Setup - Variable Speed Boiler Pump
 - a. 0-10 Vdc Output functionality allows for control of a variable speed boiler pump.
 - b. Connect the output to the 0-10 Vdc input of the pump.
 - c. For setup and tuning of variable speed boiler pump parameters, refer to [page 87](#).
4. Operation - Variable Speed Boiler Pump
 - a. VARIABLE SPEED MAX RATE VOLTS is desired voltage delivered to the pump when at High Fire.
 - b. VARIABLE SPEED MIN RATE VOLTS is desired voltage delivered to the pump when at Low Fire.
 - c. VOLTS WHEN BURNER OFF is desired voltage delivered to the pump when the burner is not active.
 - d. When the burner is active, the voltage output scales based on the boiler rate and the constraints of VARIABLE SPEED MIN/MAX RATE VOLTS.

TT or end switch inputs
(INPUTS 2, 3, 4)
0-10 Vdc Outputs

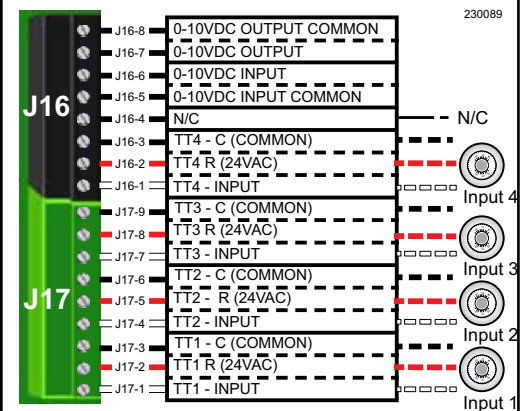

N. Multiple Boiler and the Modbus Connection

Connector J12

1. The boiler control is capable of multiple boiler communication and can control up to eight Unity™ 1.0 and 2.0 boilers in one installation.
2. To activate the Modbus communications, navigate to the Contractor menu by holding the WM logo, then press the <MODBUS SETTINGS> button. Adjust the settings displayed according to the system requirements of the BMS.
3. When converting to LONmark or BACnet, see the ProtoNode guide.
4. See the Advanced Manual for further details.

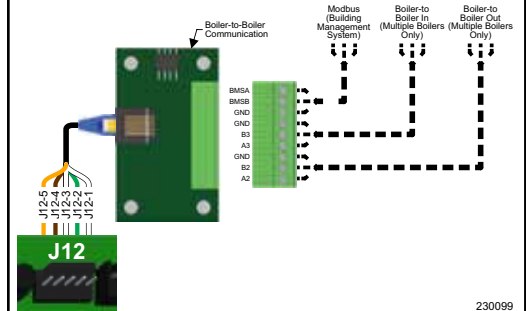

230099

O. Touchscreen Display Connection

Connector J13 or J14

1. The electronic color touch screen display is factory wired to the control and is connected to the J13 or J14 connector.
2. The display harness is wired to a spring terminal on the mounting bracket. The wires are as below. J14 is used as the example. J13 uses the same wiring pin out on the control board.
 - a. J14-1 White to A+
 - b. J14-2 Green to B-
 - c. J14-3 Black to C
 - d. J14-4 Red to R



Assembled From tested components Complete system not tested

- This device complies with Part 15 of the FCC Rules. Operation is subject to the following two conditions: (1) this device may not cause harmful interference, and (2) this device must accept any interference received, including interference that may cause undesired operation.

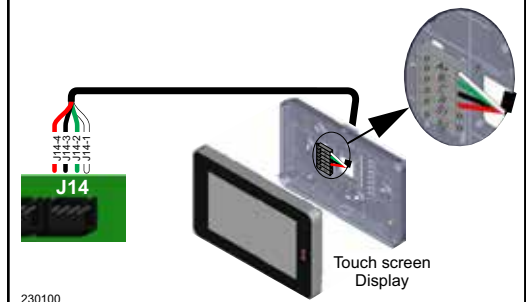

230100



Zoning with the Control

A. Zoning with Circulators – Suggested Applications

Four space heating zones (no Indirect DHW)

- Review wiring information in Section B on page 72 and Section C on page 73.
- The configuration at right uses the four input and output pairs to receive thermostat inputs on J17-1/2, J17-4/5, J17-7/8 and J16-1/2; and circulator outputs as shown.
- Choose the space heating system type that matches the heating system during the Wizard setup, or choose manually in the PRIORITY 2 menu in the System Settings menu.
- Use the factory default settings for the system type chosen, or change if needed.

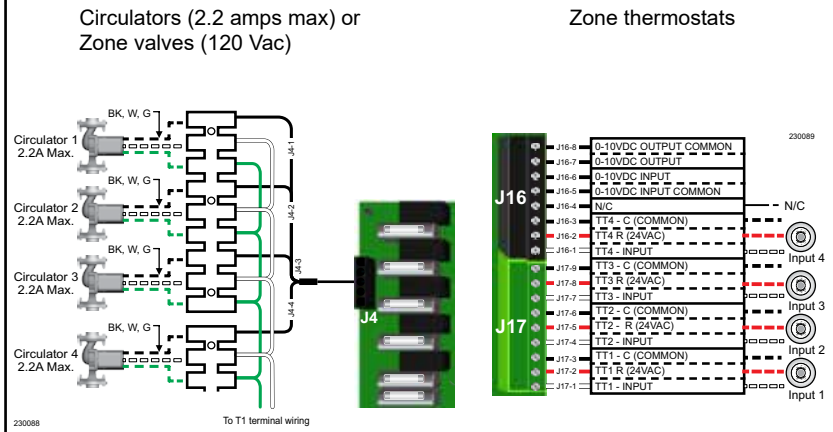

Three space heating zones plus Indirect DHW piped directly to boiler

- Review wiring information in Section B on page 72 and Section C on page 73.
- The configuration at right uses Inputs 2, 3, and 4 for space heating thermostats. Input 1 uses the input from a DHW aquastat.
- Assign INPUTS 2, 3, and 4 to PRIORITY 2. To set up PRIORITY 2, choose the space heating system type that matches the heating system during the Wizard setup, or choose manually in the PRIORITY 2 menu in the System Settings menu.
- Assign INPUT 1 to PRIORITY 1.
- Use the factory default settings for DHW and the heating system type chosen, or change if needed.

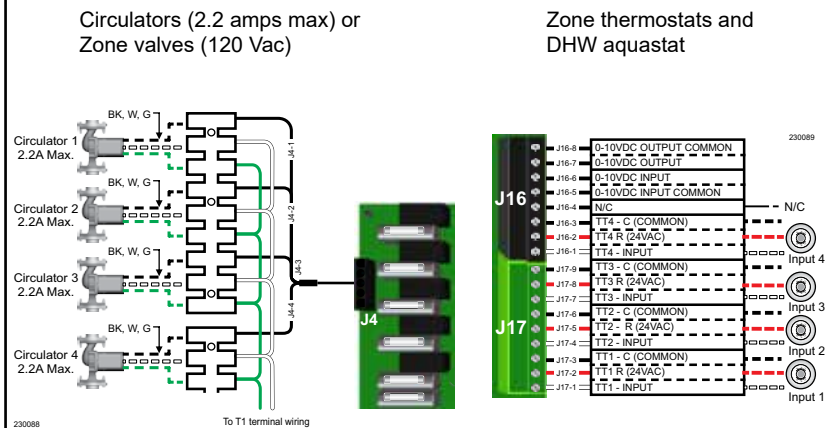

B. Zoning with Zone Valves – Suggested Applications

Connector J16 #5 and #6

⚠WARNING

The system must be equipped with a by-pass pressure regulating valve. Flow can occur with zone valves closed. Failure to comply can result in severe personal injury, death, or substantial property damage.

1. Review wiring information in Section B on [page 72](#) and Section C on [page 73](#).
2. The configuration at right uses Inputs 2, 3, and 4 for space heating thermostats. Input 1 is reserved here for configuring the operation of the system circulator.
3. Assign INPUTS 2, 3, and 4 to PRIORITY 2. To set up PRIORITY 2, choose the space heating system type that matches the heating system during the Wizard setup, or choose manually in the PRIORITY 2 menu in the System Settings menu.
4. Use the factory default settings for the heating system type chosen, or change if needed.
5. Assign INPUT 1 to AUX PUMP/OUTPUT. Then select <INPUTS PRIORITY SETTING> when prompted for output activation timing. This will cause the system pump to run when either of the zones calls for heat. Confirm that Priority 2 – RUN AUX PUMP/OUT is set to YES.
6. INPUT 1, J17-1 and -2 cannot be used for a wired connection because they are being used in the control setup to run the system circulator.

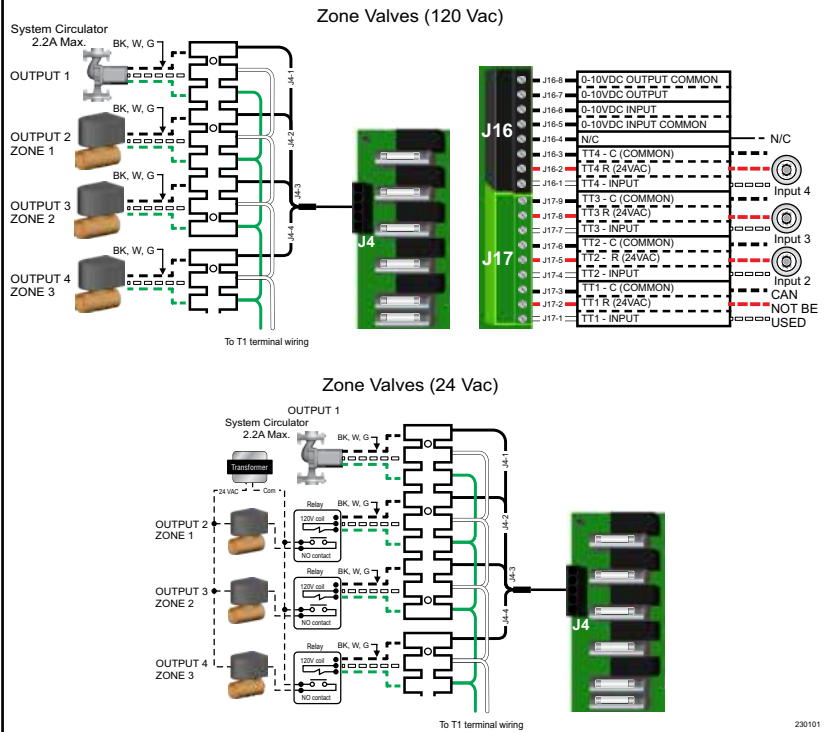

3

This page intentionally left blank



SECTION 4

Operation

This section is intended to provide instructions for control setup and boiler startup procedures.

Section Contents

Control Setup and Operation	83
Startup — Fill the System	92
Startup — Final Checks	95
Startup Procedure	98

Control Setup and Operation

Control Overview

This manual covers basic boiler control operation and setup. Refer to the SVF Advanced Manual (part number 550-100-207) for a walk-through of the complete control setup for more complex boiler applications.

- Control inputs and outputs allow operation of multiple heating circuits (space heating and DHW, for example).
- Up to three priority levels can be set, providing automatic switch-over on demand.
- The control responds to signals from the room thermostats, DHW aquastats (if used), boiler sensors (Boiler Out, Boiler In, flue temperature), system sensors, and outdoor temperature sensor, if used.
- The control automatically adjusts blower speed to match boiler output to space heating and DHW heating demand.
- The default control settings provides up to four space heating zones. The control can be easily set up for operation with a DHW zone, with or without domestic priority.
- The Wizard leads through a step-by-step setup procedure designed for the application chosen.
- Context-sensitive help is available to explain the purpose of key setup items.

Control Setup

1. Set control parameters using the Wizard option provided on initial start-up, or manually enter parameters using control menus. See the Advanced Manual (550-100-207) and the following pages for more information.
2. See Express Setup instructions in the Advanced Manual for systems and minimum settings required.

▲WARNING

BOILER MODEL, ALTITUDE, and FUEL TYPE are critical settings. Failure to set these correctly can result in severe personal injury, death, or substantial property damage.

NOTICE

Ensure the control is set for the proper water temperatures for the system. Excessive water temperature can result in significant property damage in some applications.

NOTICE

Multi-temperature systems — If the heating system includes both circuits that require lower temperature water and higher temperature circuits, protect the low-temperature circuits with limit controls that are wired to an control external limit circuit. Failure to provide regulation can result in substantial property damage.











Control Setup and Operation, continued

Control Features

- ❑ Upload, adjust settings, and perform easier diagnostics via wireless communication.
- ❑ Color touch-screen display for ease of operation monitoring and troubleshooting.
- ❑ Easy configuration with Wizard step-by-step setup including on-screen help.
- ❑ The SVF control can communicate to other SVF controls and to existing Unity™ and Unity™ 2 controls in a multi-boiler network.
- ❑ Three programmable priority assignments for up to four heat inputs.
- ❑ Preset operating parameters for typical heating systems, including target temperatures, reset curves and circulator assignments.
- ❑ Integral outdoor reset option, with reset curves matched to the system type selected.
- ❑ Modbus communications for external communication and monitoring.
- ❑ 0-10 Vdc input modulation or remote target input.
- ❑ Five configurable outputs, including one internal boiler circulator output.
- ❑ Additional heat demand operation to call a second heat source to help supply the energy required for heating.
- ❑ Advanced PI response to anticipate system needs.
- ❑ Flue temperature modifier to target temperature.
- ❑ Modulation based on flue sensor and boiler out sensors.
- ❑ Dual temperature sensors on boiler outlet and flue, providing redundant protection.
- ❑ Boiler is shipped with an outdoor sensor.
- ❑ Blower speed modulation to control boiler firing rate.
- ❑ Alarm relay on error/fault for use with an audible safety.
- ❑ Blower calibration – allows fine tuning of blower control to reach purge speeds faster, reducing time to heat delivery.
- ❑ Temperature units – Select between using °F or °C.
- ❑ Manual Reset High Temperature Limits – Set High Limit temperature safety value.
- ❑ Daylight Saving Time – Select whether your boiler will obey Daylight Savings Time for your region.
- ❑ 0-10 Vdc Output to control classic lead/lag systems and variable speed boiler pumps.

Table 13 Control sequence of operation

Display status text	Control action (Also see the Advanced Manual)
POWER UP	<ul style="list-style-type: none"> • Check the boiler model listed on the power-up screen. If it is not correct, turn off the boiler. See page 91 and the Advanced manual for instructions to change setting. • When power is turned on, the screen lists sensors that are detected. If any sensor is not listed, make sure it is connected correctly. Turn off power and restart.
 Standby	<ul style="list-style-type: none"> • Standby – no calls for heat. • Toggles through zero dots up to three dots while in standby (wrench symbol will show instead if maintenance is needed).
 Blower Prepurge	<ul style="list-style-type: none"> • Call for heat detected. • Display on with BLUE (space heating) or PURPLE (DHW) banner. • Start min/max timers if more than one system is calling - highest priority starts first. • Start circulators for this priority setup based upon settings. • Calculate target temp – If sensor temp is below target temp, begin firing sequence. • Blower to ignition speed for prepurge.
 Ignition	<ul style="list-style-type: none"> • After prepurge times out, begin ignition cycle. • Activate gas valve and ignition spark. • Continue ignition spark for ignition period. • Turn off spark and use electrode to check for flame signal.
 Space Heating	<ul style="list-style-type: none"> • Flame detected. • Release boiler to modulation. • NOTE: If flame is not detected, the gas valve is turned off, blower turns on (postpurge), and control starts cycle again. After five failures, the control waits 60 minutes, then tries again. • If priority timer times out, switch to next priority and start priority timer. • If demand satisfied, go to postpurge.
 DHW Heating	<ul style="list-style-type: none"> • Flame detected. • Release boiler to modulation. • NOTE: If flame is not detected, the gas valve is turned off, blower turns on (postpurge), and control starts cycle again. After five failures, the control waits 60 minutes, then tries again. • If priority timer times out, switch to next priority and start priority timer. • If demand satisfied, go to postpurge.
 Blower Postpurge	<ul style="list-style-type: none"> • Demand satisfied (temperature reaches target temp or limit setting). • Gas valve off. • Blower to ignition speed for postpurge. • Return to standby after purge.
 Maintenance	<ul style="list-style-type: none"> • Display banner turns BLUE, toggling between graphic screen and maintenance screen if maintenance schedule timer times out. • Will show during standby only. • Boiler operates as normal.
 Error/fault	<ul style="list-style-type: none"> • Display banner turns RED due to error or limit event.
 WWSD	<ul style="list-style-type: none"> • Warm weather shut down - the boiler is not allowed to fire on space heating if the outdoor temperature is greater than the WWSD setting. • DHW operation is not affected by WWSD.

Sequence of Operation

A summary of the control sequence is shown in [Table 13, page 84](#). The statuses shown appear in the display as the control cycles the boiler. See [Figure 64, page 89](#) for screen shots. The display banner will be red if a problem has been detected.

Control Priorities, Inputs, and Outputs

- For heating installations with multiple systems, the control uses priorities to determine the order of operation of the systems. The control’s MAX and MIN time settings determine the maximum and minimum times a system will be operated before being turned off to allow another system to operate. A typical example is DHW priority — heat demand from the DHW system is given preference over space heating, if set to use Priority 1.
- The MAX ON TIME setting controls the maximum time a priority will be allowed to run before switching to a lower priority’s call for heat. The MIN ON TIME setting controls the minimum time a priority will be operated before switching to a higher priority’s call for heat, or the next lower priority.
- Each Priority has its own set of operating parameters. The control prompts the user to select the system type and is factory programmed with parameters suited to each of these system types. The user can also choose <CUSTOM> to create a system type.
- The 120 Vac power output to the boiler circulator is provided by a terminal block located on the boiler’s control board. For each of the priorities, the control can be setup to run the boiler pump or to leave it off.
- Each boiler has up to four input and output pairs (INPUT/OUTPUT 1, 2, 3 and 4). Control setup prompts the user to assign each of these I/O pairs to a Priority. The control then knows which system (priority) to operate when the input receives a call for heat. On a call for heat to an input, the control closes the corresponding output (120 Vac), and begins controlling the boilers according to the setup for the assigned priority.
- Multiple inputs that are set up on the same priority will run at the same time if the priority and inputs are active.

Table 14 Steps for boiler setup

Setting Up the Boiler	
STEP 1	Determine input/output needs – What are the inputs? – Thermostats, remote contacts, end switches, and other. What does each control’s output need to do? – Operate a pump, activate an air louver, and other.
STEP 2	Install the boiler following all instructions in the Boiler Manual before proceeding further. Connect wiring to the control inputs and outputs to accomplish the purposes set in Step 1.
STEP 3	Follow instructions in the Boiler Manual to start up and power the boiler.
STEP 4	Use the Wizard (recommended), or enter control parameters manually (skip Wizard).

Table 15 Wizard sequence

WIZARD Sequence	
Boiler Settings	<ul style="list-style-type: none"> • Altitude must be set correctly for proper operation. • WWSD – set outdoor temperature above which space heating will be deactivated. • Fuel (natural gas or propane) must be set correctly for proper operation. The control will pause until this value is selected. • Set date and time – important for control diagnostic logging.
Inputs/Outputs	<ul style="list-style-type: none"> • Select the usage of Inputs 1, 2, 3 and 4. • Determine usage of Outputs 1, 2, 3 and 4 (outputs correspond to inputs).
Set Priorities	<ul style="list-style-type: none"> • Assign priorities 1, 2 and 3 to the inputs.
System Types	<ul style="list-style-type: none"> • Specify what system type is connected to each of the four outputs; each system type causes the control to preset operating temperatures.
System Settings	<ul style="list-style-type: none"> • Set system settings or leave at their defaults.
Output Activation	<ul style="list-style-type: none"> • Select when to activate AUX PUMP/OUTPUT (when applicable).
Priority Switching	<ul style="list-style-type: none"> • Set maximum and minimum timings for priorities.
Information	<ul style="list-style-type: none"> • Set installer name and contact information. • Enter CP number, install date, etc. • Choose to activate Maintenance Reminder by selecting and adjusting Interval settings.

Control WIZARD

The Wizard is available on initial setup of the boiler. It leads through a step-by-step setup procedure designed for the application chosen. See [Table 15](#). Context-sensitive help is available to explain the purpose of key setup Items.

Control Setup and Operation, continued

Control Operation

1. The control responds to signals from:
 - a. Room thermostats.
 - b. DHW aquastats (if used).
 - c. Temperature sensors Boiler Out, Boiler In, flue temperature and when used, outdoor temperature. For optimal performance, it is recommended to install System Supply and Return sensors.
2. The control automatically adjusts blower speed to match boiler output to space heating and/or DHW heating demand.
3. The control provides up to four inputs and four outputs (for circulators or auxiliary devices), plus a fifth boiler circulator output based on selected boiler model.
4. The outdoor temperature is used for target temperature reset operation and for the Warm Weather Shut Down (WWSD) option.
5. The control provides presets by system type. For a complete list, see the Advanced manual (part number 550-100-207).

Outdoor Temp for Min Target

OUTDOOR TEMP FOR MIN TARGET means the outdoor temperature at which the target temperature reaches its minimum (Min Target Temp). In the examples of Figure 60, this occurs at 70 °F (the factory default).

Outdoor Temp for Max Target

OUTDOOR TEMP FOR MAX TARGET means the outdoor temperature at which the target temperature reaches its maximum value (Max Target Temp). In the examples of Figure 60 this occurs at 0°F outdoor (the factory default setting).

OUTDOOR TEMP FOR MAX TARGET should equal the Outdoor Temp (outdoor design temperature) for the installation's location.

Figure 60 Outdoor reset operation

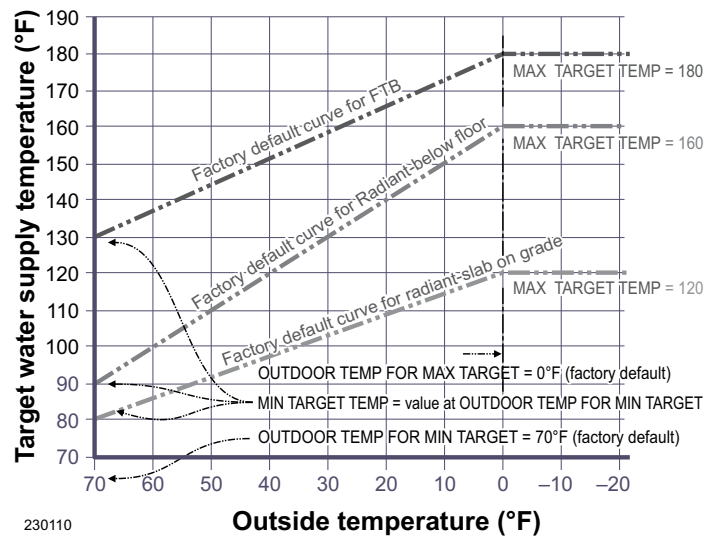

Outdoor Reset Operation

Set desired temperatures for space heating zones. For an explanation of the target temperatures and associated outdoor temperatures, see Figure 60.

The temperature settings discussed below are accessed in the priority menu for the applicable system. For detailed explanations of the priority menus, see the Advanced manual.

Max Target Temp:

Set MAX TARGET TEMP to the required supply water temperature for the system at design maximum heat loss; this is typically 180°F for finned tube baseboard on new installations.

Min Target Temp:

MIN TARGET TEMP should equal the desired minimum supply water temperature for the system.

The Min Temp is the setpoint whenever the ODT temp is above the ODT For Min Target and below the WWSD temps.

IMPORTANT

Setting the MIN TARGET TEMP value below the OUTDOOR TEMP FOR MIN TARGET may reduce the performance of the heating system at warmer outdoor temperatures.

Remote Target Operation (0–10 Vdc input)

1. This function allows a remote analog input to regulate the supply temperature for control operation/modulation. This can be done for any priority.
2. The settings discussed below are accessed in the priority menu for the applicable system. For detailed explanations of the priority menus, see the Advanced manual (part number 550-100-207).
3. See Figure 61 for an explanation of target temperature vs voltage when using remote target operation.
4. In the priority menu for the applicable system, select <0-10V> for the TARGET ADJUST setting.
5. In the same priority menu, select the <VOLTS FOR MIN TARGET> and <VOLTS FOR MAX TARGET> values. VOLTS FOR MIN TARGET sets the voltage value for the desired minimum supply temperature. VOLTS FOR MAX TARGET sets the voltage value for the desired maximum supply temperature.

Remote Modulation Operation (0–10 Vdc input)

1. To use 0-10 Vdc for remote modulation:
 - a. Go to Contractor Menu -> System Settings and select the appropriate priority.
 - b. Select <INPUT 2> from System Setting menu, then change the Input 2 source to 0-10V.
 - c. The priority that is assigned to Input 2 cannot be used by any other Input.
2. The boiler comes on at 0.9 Vdc and turns off at 0.6 Vdc. 1 Vdc = 10% input. 10 Vdc = 100% input. These voltage settings are adjustable.

Variable Speed Boiler Pumping (0–10 Vdc output)

1. Control Setup – Variable Speed Boiler Pump.
 - a. 0-10 Vdc Output functionality allows for control of a variable speed boiler pump.
 - b. Connect the output to 0-10 Vdc input of the pump.
 - c. From the Contractor menu, navigate to Diagnostics -> Manual Test Mode. See Figure 62. With FORCE RATE highlighted, select <EDIT> then use the arrows to force to <HIGH> and press <SAVE>.

Figure 61 Remote target operation

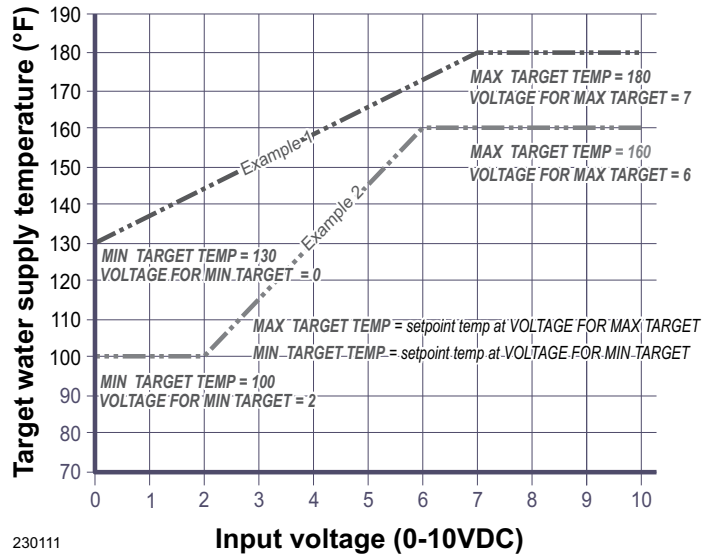

230111

Figure 62 Manual test mode screen

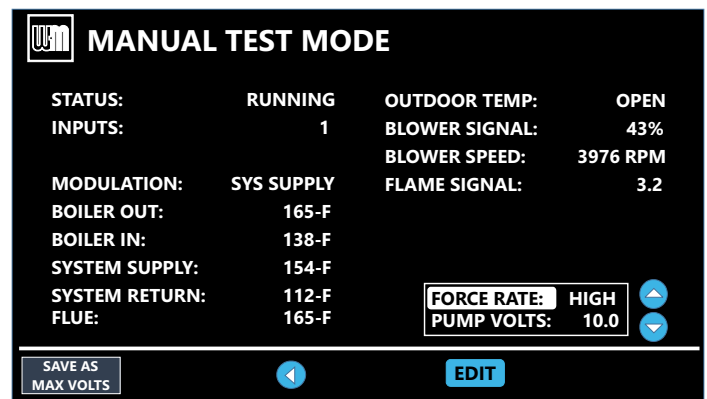

- d. Adjust the desired voltage to the desired delta T of the boiler and <SAVE AS MAX VOLTS>. Change the Pump Volts setting to AUTO to edit FORCE RATE again. Repeat for each FORCE RATE speed. Ignition speed rate sets voltage delivered to the pump when the burner is not active.
2. Operation – Variable Speed Boiler Pump.
 - a. VARIABLE SPEED MAX RATE VOLTS is desired voltage delivered to the pump when at high fire.
 - b. VARIABLE SPEED MIN RATE VOLTS is desired voltage delivered to the pump when at low fire.
 - c. VOLTS WHEN BURNER OFF is desired voltage delivered to the pump when the burner is not active.
 - d. When the burner is active, the voltage output scales based on the boiler rate and the constraints of VARIABLE SPEED MIN/MAX RATE VOLTS.

Control Setup and Operation, continued

Essential Control Settings

Figure 63 Boiler essential settings, REQUIRED on initial start-up.

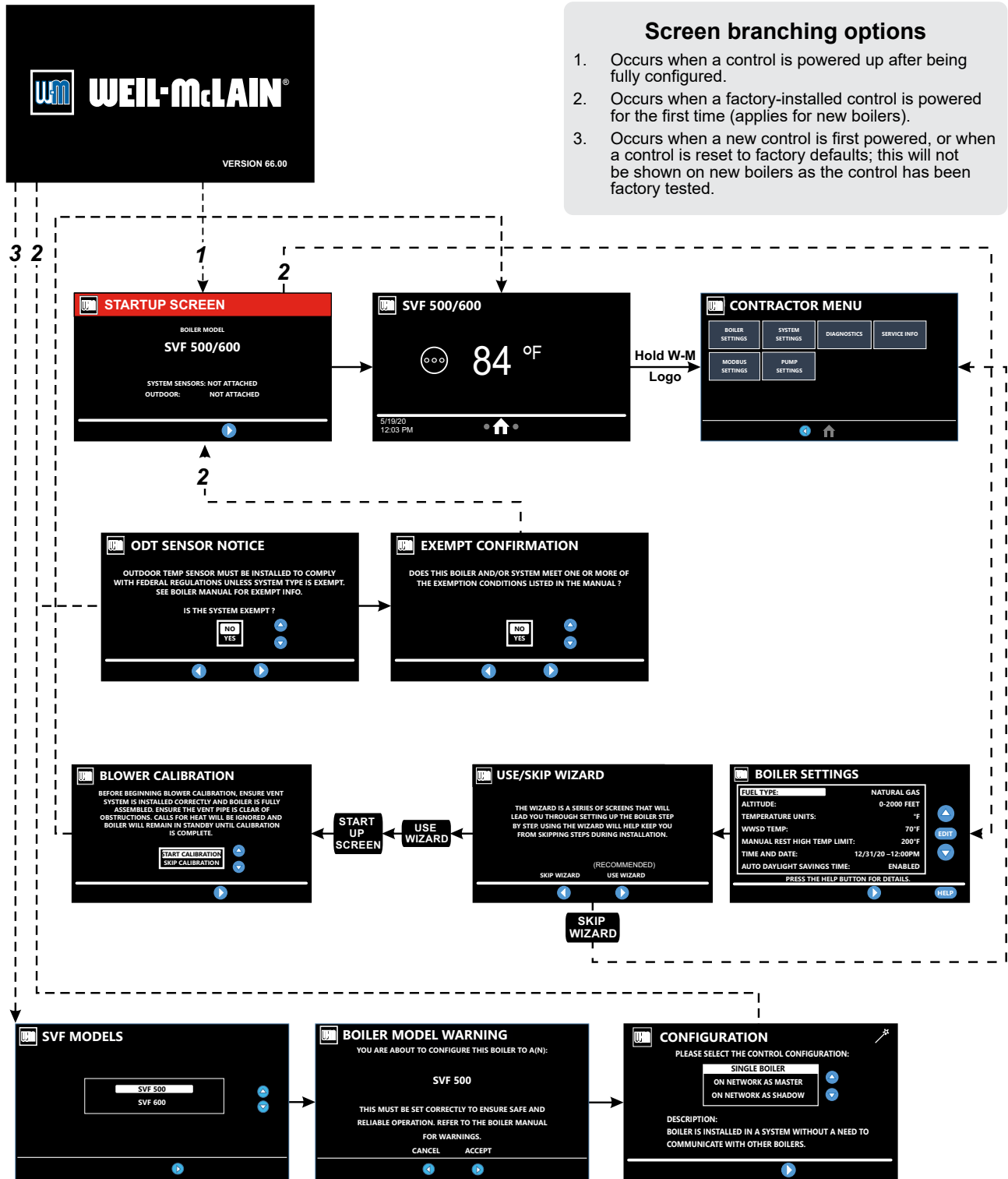

Screens shown above are typical only.
Actual screens depend on control settings chosen.

4

230002



Control Settings Menus

Figure 64 Control display screens and typical navigation – advanced mode, multiple boilers

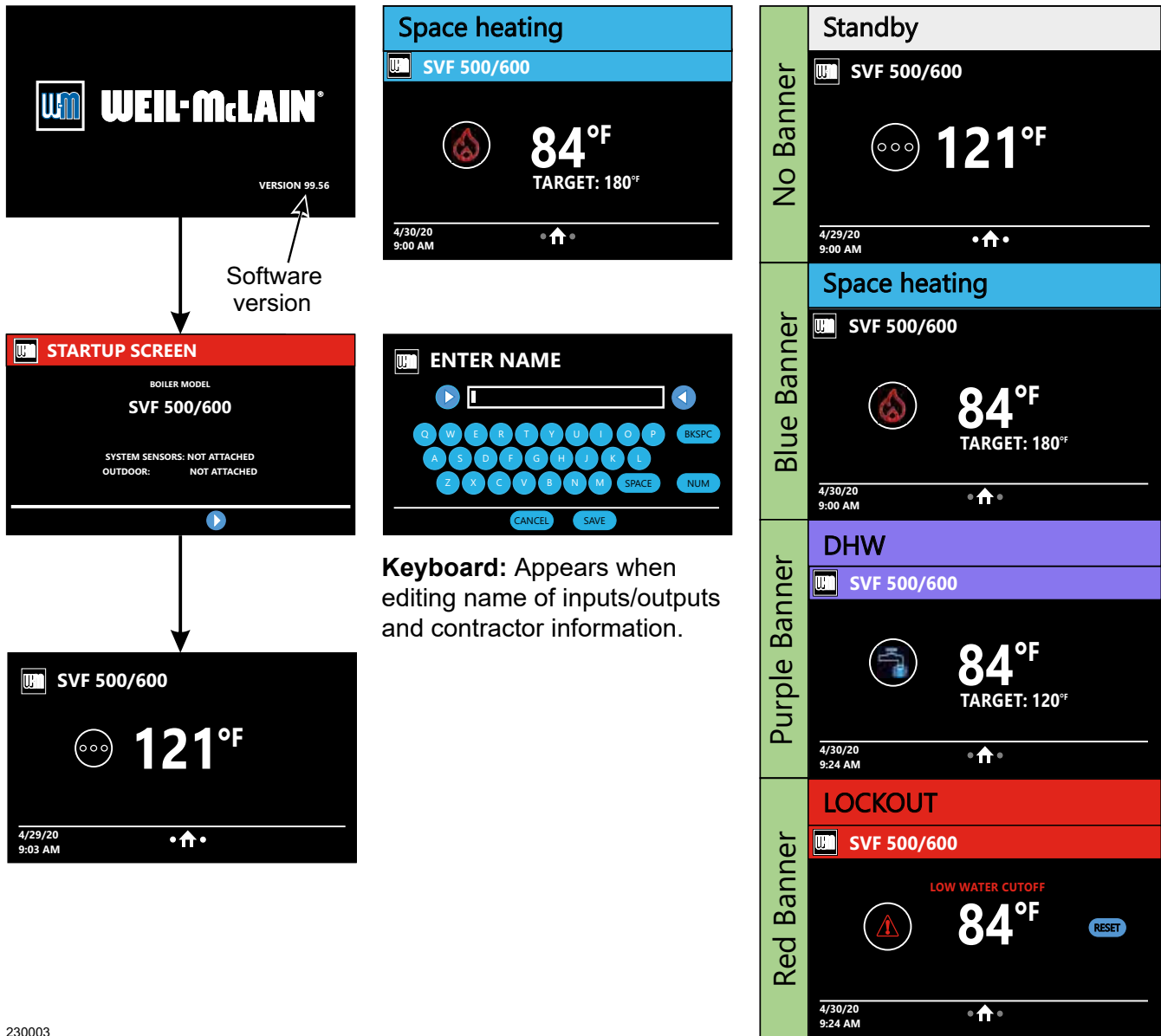

230003

Navigation Controls

- Swipe:** Slide finger left or right on the screen to navigate forward and backward on applicable screens.
- Press:** Touch icons on screen to perform specified action.
- Scroll:** Place finger on slide bar empty space and hold to scroll. Applicable screens can also be swiped up or down to scroll.
- Double tap:** Applicable on editable parameters. Allows user to enter edit mode by double tapping parameter.

Screens shown above are typical only.
Actual screens depend on control settings chosen.



Control Setup and Operation, continued

Connecting the Boiler

This section shows basic and required information on menu navigation for boiler connectivity.

For more information and settings see the Advanced Manual (part number 550-100-207).

Figure 65 NAVIGATION menus

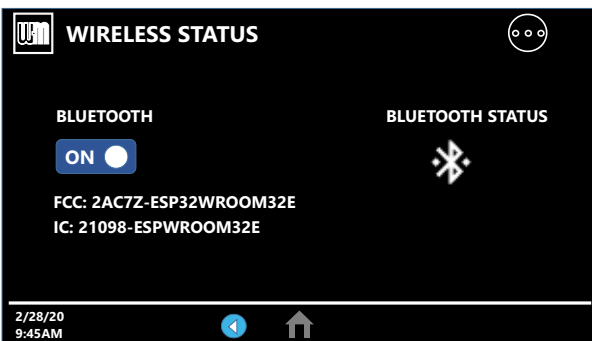
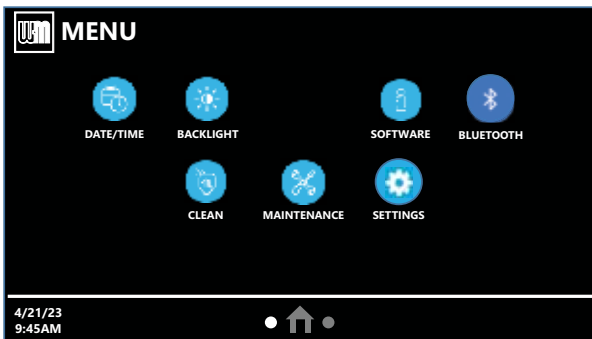
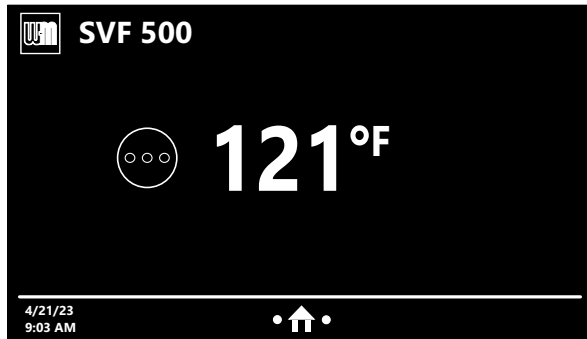

Menu Item	Purpose
HOME SCREEN	<ul style="list-style-type: none"> • Banner info • Status image • Fault name and reset button • Time/Date • Navigation buttons – 2 dots and Home • Current temperature • Target Temperature (when a priority is active)
BLUETOOTH®	<ul style="list-style-type: none"> • Allows the user to turn Bluetooth ON or OFF. Swipe right from HOME and press <BLUETOOTH> to reach FCC and IC information. • Bluetooth allows the user to connect remotely to the WM ProTool app for wireless communication to the boiler. The app functions include, but are not limited to, allowing the user to install the latest software for their boiler control, display, and Bluetooth radio, giving quick access to boiler information, and providing contact information to WM Technical Services. <p>FCC: Wireless device unique identifier registered with the U.S. Federal Communications Commission.</p> <p>IC: Wireless certification approval number unique to all devices, required for Canada.</p> <ul style="list-style-type: none"> • This device complies with Part 15 of the FCC Rules. Operation is subject to the following two conditions: (1) this device may not cause harmful interference, and (2) this device must accept any interference received, including interference that may cause undesired operation.
 Assembled From tested components. Complete system not tested.	

Screens shown on these pages are typical only. Actual screens depend on control settings chosen.

Contractor Menus

⚠ WARNING

BOILER MODEL, ALTITUDE, and FUEL TYPE are critical settings. Failure to set these correctly can result in severe personal injury, death, or substantial property damage.

Access Contractor menus by pressing the WM Logo for seven seconds from the Home screen. See the Advanced Manual for more settings and information.

Service Menus

Use this section to enter contractor’s information, Consumer Protection (CP) number, install date, and an automatic notice for maintenance (default is 12 months). The notice for maintenance shows on the display and automatically notifies the owner of the need for scheduled maintenance by the technician. Select <RESET REMINDER> to reset for the next maintenance date.

Figure 66 CONTRACTOR menus

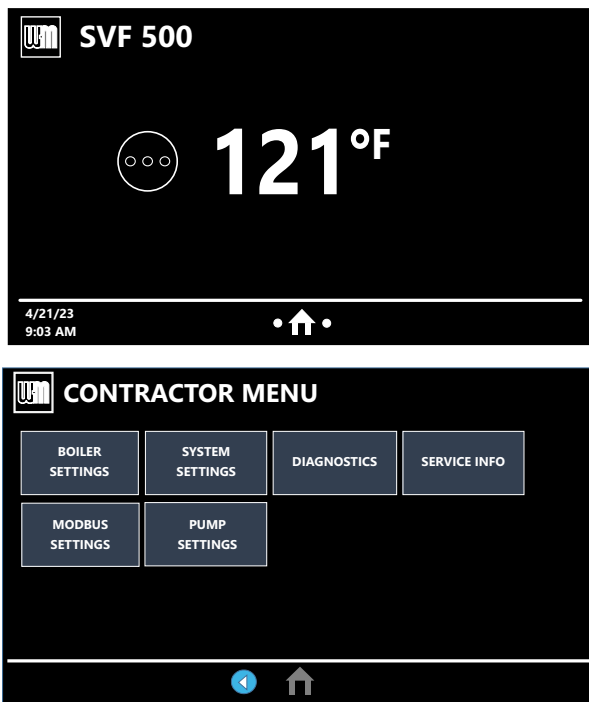

Menu Item	Purpose
BOILER SETTINGS	<ul style="list-style-type: none"> • Set or change boiler model, control type, high altitude setting, ODT sensor requirement, manual reset high limit, and WWSD temperature settings. • Outdoor sensor temp adjustment. • Restore to factory default option. • Fuel type and blower calibration.
SYSTEM SETTINGS	<ul style="list-style-type: none"> • These settings assign Priority 1, 2, or 3 to each of the four inputs to the control and provide an overview of assigned priorities.
DIAGNOSTICS	<ul style="list-style-type: none"> • Use to review current and historical information, including previous lockouts. • Use to access Manual Test Mode.
SERVICE INFO	<ul style="list-style-type: none"> • Used to set contractor contact information, boiler information and maintenance dates.

Figure 67 SERVICE menus navigation

Service Info	Comment
Name	Contractor name to appear in maintenance reminders and during lockouts
Phone	Contractor phone number
Model	Displays the boiler model selected in the boiler setup
CP Number	Enter the CP# of the boiler
Installed	Enter the date the boiler was installed
Last Maintenance Performed	Date automatically entered when RESET REMINDER is chosen by contractor
Next Maintenance Due	Date automatically calculated when RESET REMINDER is selected by contractor
Interval Settings	Contractor selects maintenance reminder frequency based on service history
Reset Reminder	Contractor selects this to update Last Maintenance Date and Next Date. Owner uses this to ignore the reminder and update only the Next Date.
Last Calibration Date	Displays date of last calibration performed.

Startup — Fill the System

Clean the System

NOTICE

The system must be thoroughly flushed, without the boiler connected, to remove sediment. The high-efficiency heat exchanger can be damaged by buildup or corrosion due to sediment, resulting in substantial property damage.

1. If necessary, use an approved chemical cleaning agent. Follow the manufacturer's guidelines for cleaning procedures.
 - a. A list of approved cleaning products is available at www.weil-mclain.com.
 - b. See the Parts section starting on [page 131](#) for Weil-McLain part numbers to obtain cleaning agents through a WM Technologies distributor.
2. For zoned systems, flush each zone separately through a purge valve.
 - a. If purge valves and isolation valves are not already installed, install them to properly clean the system.
3. Flush the system until water runs clean. Ensure that all piping is free of sediment.

NOTICE

DO NOT use petroleum-based cleaning or sealing compounds in the boiler system. Damage to elastomer seals and gaskets could occur, resulting in substantial property damage.

NOTICE

Install a strainer or other mechanical separator device if necessary to ensure sediment will not enter the boiler.

Water Chemistry

Water pH between 7.0 and 8.5

1. Maintain boiler water pH between 7.0 and 8.5. Test the water with litmus paper, or have it chemically analyzed by a water treatment company.
2. If pH differs from above, consult a local water treatment company for treatment needed.
3. Softened water may be used to fill boiler provided that Sentinel X100 is also added to the system at the proper dosage and properly maintained. Softened water must NOT be used without Sentinel X100 as boiler corrosion may occur.

Hardness must be less than 7 grains

Consult local water treatment companies for unusually hard water areas above 7 grains hardness.

Chlorine concentration must be less than 150 ppm

- Filling the system with chlorinated fresh water should be acceptable since the chlorine levels in drinking water are typically less than 5 ppm.
- Do not use the boiler to directly heat swimming pools or spa water.
- Do not fill boiler or operate with water containing chlorine in excess of 150 ppm.

NOTICE

Before filling the boiler and system with water, verify the water chemistry complies with these instructions. Verify that the water chemistry meets the limitations and requirements of all other equipment in the system. Failure to comply can result in boiler failure or unreliable operation.

Freeze Protection

⚠ WARNING

Failure to comply with these guidelines can result in severe personal injury, death, or substantial property damage.

Never use automotive or standard glycol antifreeze, even glycol made for hydronic systems. Use only freeze-prevention fluids recommended by WM Technologies for applications in SVF boiler systems. Thoroughly flush any system that has used glycol before installing the new SVF boiler.

Do not exceed 50% antifreeze by volume. Antifreeze is more sluggish than water, and can interfere with heat transfer. Sludge can develop in the boiler with antifreeze concentrations higher than 50%, potentially causing damage to the heat exchanger.

Always drain and flush the system thoroughly before filling with antifreeze. Sludge, iron, oxide

deposits, and other sediment in the system inhibit flow and can cause rapid breakdown of inhibitors.

Install a water meter or monitor water make-up when using freeze protection fluid with automatic fill. Antifreeze may leak before the water begins to leak, causing concentration to drop and reducing the freeze protection level.

Test antifreeze concentration at least annually. If concentration is low, either add antifreeze to the current mixture, or drain the system and refill with the correct mixture. Running the system with low antifreeze concentration can result in substantial property damage.

Review the material safety data sheet (MSDS) with the boiler owner for the fluid used. Leave a copy with the owner for reference. The MSDS contains information on potential hazards and first aid procedures for exposure or ingestion.

Antifreeze

Senitel X500 antifreeze is approved for use in SVF 500/600 boilers. See the Parts section starting on [page 131](#) for obtain antifreeze through a Weil-McLain distributor. Other approved antifreezes are listed on weil-mclain.com.

Read all warnings above before using any freeze protection in the boiler system.

Use the correct amount of antifreeze:

1. Determine the freezing temperature needed to protect against the lowest likely temperature the system water will encounter.
2. Find the antifreeze percentage (concentration by volume) needed for the freezing temperature from the antifreeze manufacturer's data on the antifreeze container.
3. Calculate the total volume (gallons) of all system piping and components, including the expansion tank and boiler. Boiler water content is listed in [Table 27, page 142](#).
4. The gallons of antifreeze required equals the total water volume multiplied by the antifreeze percentage required.
5. Verify that the water flow rate and temperature rise with antifreeze is in line with [Table 5, page 21](#) requirements.

Startup — Fill the System, continued

Fill and Test the Water System

1. Fill the system only after ensuring the water meets the requirements of this manual.
2. Close the manual and automatic air vents and boiler drain valve.
3. Fill to correct system pressure. Correct pressure will vary with each application.
 - a. Pressure will rise when the boiler is turned on and system water temperature increases.
 - b. Operating pressure should be no higher than 80% of the relief valve setting for most systems.
4. At initial fill and during boiler startup and testing, thoroughly check the system and repair all leaks.

NOTICE

Eliminate all system leaks. Continual fresh make-up water will reduce boiler life. Minerals can build up, reducing heat transfer, overheating the heat exchanger, and causing heat exchanger failure.

5. After the system has been filled and leak tested, verify that the water pH and chloride concentrations are acceptable.
6. Verify antifreeze concentration, when used.

Recommended Inhibitor

Adding Sentinel X100 to the boiler system will prevent damage to the heat exchanger. See [page 131](#) for ordering information.

1. After filling the system as directed in these instructions, add X100 following the instruction on the container.
2. After adding the inhibitor to the system, allow time for the water to circulate and mix. Check the inhibitor level. Add additional inhibitor if necessary.
3. See manufacturer instructions or www.weil-mclain.com to determine how much inhibitor to use.

IMPORTANT

Check inhibitor level at least annually as inhibitor levels may change over time. Add an inhibitor as needed to bring to an acceptable level. Use an inhibitor test kit to verify.

Purge Air from the Water System

1. Connect a hose to the purge valve. See purge/drain valves shown in piping diagrams beginning on [page 22](#). Route the hose to an area where water can drain and be seen.
2. Close the boiler or system isolation valve between the purge valve and fill connection to the system.
3. Close the zone isolation valves.
4. Open the quick-fill valve on the cold water make-up line.
5. Open the purge valve.
6. Open the isolation valves one zone at a time. Allow water to run through, pushing out air until no air flow is present. Close the isolation valves and proceed to the next zone. Repeat until all zones are purged.
7. Close the quick-fill water valve and purge valve. Remove the hose. Open all isolation valves. Watch that the system pressure rises to correct cold-fill pressure.
8. Operate and purge the system to eliminate trapped air.

System without purge valves:

1. If purge valves are not installed, open manual air vents in the system one at a time, beginning with the lowest floor. Close the vent when water comes out.
2. Repeat with the remaining vents.
3. Refill the system to the correct pressure.

System with a diaphragm-type or bladder-type expansion tank:

1. Open the automatic air vent one turn. These vents are used on diaphragm-type or bladder-type expansion tanks only.
2. Refill the system to the correct pressure.

Check Concentrations Annually

1. Test the pH of a sample of system water at least annually. The pH of the water mixture must be between 7.0 and 8.5. Alternately, use the Sentinel inhibitor test kit to check concentration.
 - a. If pH is outside this range, or the inhibitor test kit indicates low level, the inhibitor level may not be sufficient to prevent corrosion.
2. Test antifreeze concentration. Follow instructions on [page 93](#) to determine the amount of antifreeze.
3. Check the inhibitor level after adjustments are made.

Startup — Final Checks

Check for Gas Leaks

Before starting the boiler, and during initial operation, use a leak detector or smell around the boiler and floor for gas odorant or any unusual odor. Remove the boiler jacket door and smell the interior of the boiler jacket.

⚠ WARNING

DO NOT proceed with startup if there is any indication of a gas leak. Repair any leak at once. Starting the boiler up when there is a gas leak could cause an explosion, which can result in severe personal injury, death, or substantial property damage.

Propane Boilers:

For boilers using propane, verify it has been converted for propane. See [page 16](#) for conversion instructions.

The propane supplier mixes an odorant with the propane to make its presence detectable. This odorant can fade in some instances, and the gas may no longer have an odor. Before startup, and periodically thereafter, have the propane supplier verify the correct odorant level in the gas.

Check Thermostat Circuits

1. Disconnect the two external wires connected to the boiler thermostat terminals. See Section C on [page 73](#) for terminal locations. See the Advanced Manual (part number 550-100-207) for information on how to perform this through the control.
2. Connect a voltmeter across these two incoming wires. Close each thermostat, zone valve, and relay in the external circuit one at a time. Check the voltmeter reading across the incoming wires.

NOTICE

There should NEVER be a voltage reading across the thermostat circuit wiring. If a voltage does occur under any condition, check and correct the external wiring. Applying voltage across the thermostat terminals will damage the control.

Figure 68 Test port cap removal

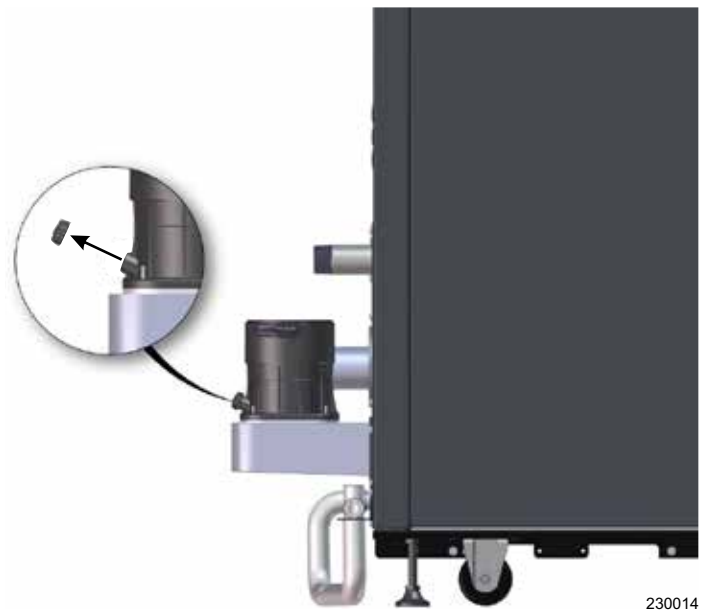

230014

3. Once the external thermostats circuit wiring is checked, and corrected if necessary, reconnect the external thermostat circuit wires. Allow the boiler to cycle.

Inspect and Fill the Condensate System

Inspect the condensate drain line, PVC fittings, and trap. See [page 61](#) for component locations.

Fill the condensate trap with water:

1. Remove the test port cap from the vent adapter. See Figure 68.
2. Pour one cup full of clean water into the test port.
3. Ensure the condensate trap is filled with water.
4. Install the test port cap onto the vent adapter.

⚠ WARNING

The condensate trap must be filled with water during boiler operation at all times to avoid flue gas emission from the condensate drain line. Failure to fill the trap can result in severe personal injury or death.

Startup — Final Checks, continued

Inspect the Pressure Switch Hose

Inspect the pressure switch sense hose and verify correct installation. See Figure 69. Replace the hose if necessary.

NOTICE

The pressure switch sense lines must be in good condition and firmly attached to the correct locations. Incorrect placement or disconnected sense lines can result in unreliable boiler operation.

Final Checks Before Starting the Boiler

- Read the instructions to adjust and set up the control module. Verify that all settings have been made correctly.
- Verify that the boiler and system are full of water and all system components are correctly set for operation.
- Vent any remaining air from the system using manual vents. Air in the system will interfere with circulation and cause heat distribution issues and noise.
- Check system piping for leaks. If any leaks are found, shut down the boiler and repair immediately.
- Fill condensate trap with water. See [page 95](#) for the procedure.
- Verify electrical connections are correct and securely attached.
- Inspect vent and air piping in direct vent systems for signs of deterioration from corrosion, physical damage, or sagging. Verify vent and air piping is intact and correctly installed per this manual.

Figure 69 Pressure switch tube locations

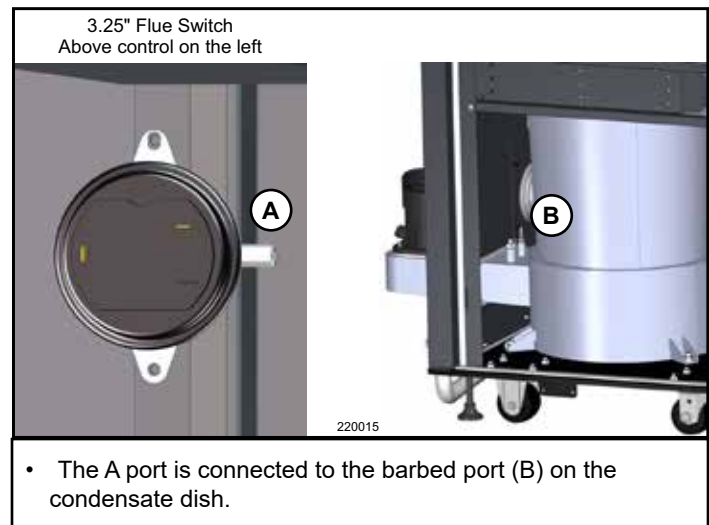

⚠ WARNING

Venting system must be sealed gas-tight to prevent flue gas spillage and carbon monoxide emissions, which can result in severe personal injury or death.

Figure 70 Operating instructions, warning

FOR YOUR SAFETY READ BEFORE OPERATING

WARNING

If you do not follow these instructions exactly, a fire or explosion may result causing property damage, personal injury or loss of life.

A. This appliance does not have a pilot. It is equipped with an ignition device which automatically lights the burner. Do not try to light the burner by hand.

B. Before OPERATING, smell all around the appliance area for gas. Be sure to smell next to the floor because some gas is heavier than air and will settle on the floor. See below.

C. Use only your hand to turn the gas valve handle. Never use tools. If the handle will not turn by hand, don't try to repair it, call a qualified service technician. Force or attempted repair may result in a fire or explosion.

D. Do not use this appliance if any part has been under water. Immediately call a qualified service technician to inspect the appliance and to replace any part of the control system and any gas control, which has been under water.

WHAT TO DO IF YOU SMELL GAS

- Do not try to light any appliance.
- Do not touch any electric switch; do not use any phone in your building.

- Immediately call your gas supplier from a phone outside the structure. Follow the gas supplier's instructions.
- If you cannot reach your gas supplier, call the fire department.

OPERATING INSTRUCTIONS

1. Stop! Read the safety information at left on this label. This appliance is equipped with an ignition device which automatically lights the burner. Do not try to light the burner by hand.
2. Set room thermostat(s) to lowest setting. Verify external manual gas cock is open (valve handle parallel to gas piping).
3. Turn OFF all electrical power to the appliance.
4. Remove boiler access door.
5. Turn boiler manual gas valve handle counterclockwise ↺ to open gas supply.
6. Wait five (5) minutes to clear out any gas. Then smell for gas, including near the floor. If you smell gas, STOP! Follow "WHAT TO DO IF YOU SMELL GAS" in the safety information to the left. If you don't smell gas, go to the next step.
7. Turn ON all electrical power to the appliance.
8. Set thermostat(s) to desired setting.
9. The display will show symbols and text describing the status of the boiler as it proceeds through its operating sequence.
10. If the appliance will not operate when there is a call for heat and piping is not hot, follow the instructions "To Turn Off Gas To Appliance" below and call your service technician or gas supplier.

**Gas valve
CLOSED**

**Gas valve
OPEN**

11. Reinstall boiler access door. Make sure panel is seated firmly in place.

TO TURN OFF GAS TO THE APPLIANCE

1. Set room thermostats to lowest setting.
2. Turn OFF all electrical power to the appliance.

3. Close external manual gas cock (valve handle perpendicular to gas piping). Remove boiler access door. Turn boiler manual gas valve handle clockwise ↻ to close gas supply.
4. Reinstall boiler access door.

550-101-262 (0824)

Startup Procedure

Starting the Boiler

1. Apply power to the boiler via the service switch.
2. Follow the operating instructions on [page 97](#).
3. If this is the first time powering the boiler, refer to the Control section starting on [page 83](#).
4. Complete the setup Wizard. The Wizard is recommended for all boilers because it guides the user through setups for multiple applications.
5. Ensure all connected sensors are detected and the correct boiler model is identified. If not, determine the cause and correct before proceeding.
6. Check water, vent, air and gas piping again for leaks. If any leaks are found, shut down the boiler and repair immediately.

Troubleshooting Startup Issues

1. Check for loose connections, a blown fuse, or if the service switch is in the off position.
2. Is gas turned on at the meter and at the boiler?
3. Are control settings correct for the application?
4. Is the warm weather shutdown activated?
5. Are thermostats set below room temperature?
6. Are external limit controls open (if used)? Is the boiler water temperature above 200°F?
7. Are the closure switch contacts open?
8. Is incoming gas pressure within the limits of the minimum and maximum values given on [page 63](#)?
9. If none of the above corrects the issue, refer to the Troubleshooting section starting on [page 119](#).

Check Flame and Combustion

1. Ensure that all load devices, such as control valves, radiators, and air handling units, are in operation to prevent the boiler from cycling off during adjustment. The load devices must be able to shed or dump the heat created by the boiler.
2. Navigate to the Manual Test Mode screen under <Diagnostics>.
3. Initiate a call for heat on a thermostat input.

High Fire Check:

4. Make sure the maximum firing rate is set to the maximum given in [Table 18, page 117](#). Adjust as necessary.

Table 16 Acceptable combustion values

Fuel	High Fire		Low Fire	
	% CO ₂	CO ppm	% CO ₂	CO ppm
NG	9.50 + 0.4 - 1.0	< 100	9.00 + 0.5 - 1.0	< 50
LP	10.50 ± 0.5	< 150	10.00 ± 0.5	< 50

- Values above are with the boiler front door removed. Values will increase about 0.2% once the door is reinstalled.
- The low fire CO₂ must be lower than the high fire CO₂ values.
 - For NG, the low fire CO₂ must be 0.40% lower than the high fire CO₂.
 - For LP, the low fire CO₂ must be 0.25% lower than the high fire CO₂.
- Values above are for altitudes up to 2,000 ft.. For higher altitudes, CO₂ may be slightly lower and CO slightly higher. Refer to [Table 18, page 117](#) for more information.
- Reinstall the boiler door after completing service.

5. While still in Manual Test Mode, and with FORCE RATE highlighted, select <EDIT>. Using the up and down arrows, select <HIGH> and press <SAVE>. Refer to [Figure 62, page 87](#).
6. Look at the flame through the flame inspection window. The high fire flame should be blue and stable. The burner surface should be covered with orange dots.
7. Remove the test port cap from the vent flue adapter. Insert a combustion test probe. For test port location, see [Figure 68, page 95](#).
8. Test for CO₂ and CO. The CO₂ values must comply with Table 16. If results are acceptable, proceed to the next step. If not, follow the instructions under the Gas Valve Adjustment section starting on [page 99](#) to set the positions of the throttle and offset regulating screws.
9. To check the natural gas input (as needed):
 - a. Turn off other appliances.
 - b. Operate the boiler for 10 minutes.
 - c. At the natural gas meter, measure time in seconds required to use one cubic foot of gas.
 - d. Calculate the gas input:

$$\frac{3600 \times 1000}{\text{number of seconds from step c}} = \text{Btuh}$$

- e. Btuh calculated should approximate input rating on boiler rating label.

Check Flame and Combustion, continued

Low Fire Check:

10. In Manual Test Mode, and with FORCE RATE highlighted, select <EDIT>. Using the up and down arrows, select <LOW> and press <SAVE>. Refer to Figure 62, page 87.
11. Look at the flame through the flame inspection window. The low fire flame should be stable, with a uniform orange color, and evenly distributed over the burner surface.
12. Repeat the combustion test as instructed in the previous steps.
13. Set the FORCE RATE back to <AUTO> and press <SAVE> before exiting the Manual Test Mode screen.
 - a. The control will automatically reset the force rate to AUTO mode 30 minutes after last button press.
14. Reinstall the vent flue cap and ensure it is sealed.

WARNING

The vent flue cap must be installed to prevent flue gas spillage into the boiler enclosure. Failure to comply can result in severe personal injury, death, or substantial property damage.

Gas Valve Adjustment

IMPORTANT

Adjust the throttle or offset screw only as needed to meet the combustion values given in [Table 16, page 98](#). Do not attempt to adjust the throttle screw at low fire. Confirmation of the correct low fire RPM must be made before adjusting the offset regulating screw.

CAUTION

Adjust the throttle and offset screws in small increments.

WARNING

DO NOT attempt to adjust the throttle or offset screws unless done by a qualified technician with calibrated combustion test instruments. Failure to comply can result in severe personal injury, death, or substantial property damage.

Figure 71 Throttle and offset regulating screws



1. Throttle screw adjustment is only necessary if specified elsewhere in this manual, or if combustion tests indicate the need. See Check Flame and Combustion on [page 98](#) for testing.
2. Boiler behavior could indicate a need to check combustion values at high fire, such as:
 - Difficulty igniting
 - Poor flame stability at low fire
 - Combustion noise
 - High carbon monoxide values
3. Combustion readings must be taken at both high fire and low fire. See Figure 71 for screw locations.
4. If gas valve adjustment does not correct the issue, shut down the boiler and contact your local WM Technologies representative.
5. For a coarse throttle adjustment on the gas valve, carefully tighten the throttle screw until it bottoms out.
 - a. For natural gas boilers, back the throttle screw out 2 and 1/4 turns after tightening.
 - b. For propane boilers, back the throttle screw out 1 and 3/4 turns after tightening.
6. Navigate to the Diagnostics menu to start adjustments.

Startup Procedure, continued

Gas Valve Adjustment, continued

High fire adjustment:

IMPORTANT

Adjust only the throttle screw for high fire.

7. Force the boiler to 100% (high fire). Ensure the blower speed has achieved the RPM listed in [Table 18, page 117](#).
8. Allow adequate time for the combustion analyzer to stabilize. Take CO₂ and CO readings. Refer to [Table 16, page 98](#) for acceptable combustion values.
9. If the CO₂ is high or low, remove the top cover of the gas valve and adjust the input with a 4 mm Allen wrench.
 - a. If CO₂ is high, turn the throttle screw CLOCKWISE in small increments to *decrease* the input.
 - b. If CO₂ is low, turn the throttle screw COUNTERCLOCKWISE in small increments to *increase* the input.
10. Allow the boiler to stabilize before taking another reading. This typically takes 20-30 seconds.
11. Continue until the desired CO₂ value is achieved.
12. Confirm that the CO is within limits.
13. Reinstall the top cover on the gas valve.

Low fire adjustment:

IMPORTANT

Adjust only the offset regulating screw for low fire.

14. Adjust the boiler to 0% (minimum output) and allow the boiler to stabilize. Confirm the RPM value during operation. See [Table 18, page 117](#).
15. Remove the T40 Torx head cap for offset screw adjustment. See [Figure 71, page 99](#).
 - a. If the CO₂ is high, turn the offset regulation screw COUNTERCLOCKWISE in *very small* increments to *decrease* the input.
 - b. If the CO₂ is Low, turn the offset regulating screw CLOCKWISE to *increase* the input.
16. Allow the boiler to stabilize before taking another reading. This may take a few minutes.
17. Continue until the desired CO₂ value is achieved.
18. Confirm that the CO is within the limits in [Table 16, page 98](#).
19. Reinstall the T40 Torx head cap.

Maximum and Minimum Final Check

1. Turn the boiler off, then restart it and put into test mode at high fire. Ensure the CO₂ setting level has remained unchanged, and confirm that CO is within limits.
2. Reduce to low fire and check the minimum rate output. Ensure the CO₂ setting level has remained unchanged, and confirm that CO is within limits.
3. Repeat the steps under high fire adjustment or low fire adjustment if necessary.
4. If any assistance is needed during the set up procedure, and the issue cannot be addressed with the information provided in this manual, contact WM Technologies Technical Services.

Check Ignition System Safety Shutoff Device

1. After the boiler has been installed, turn off the boiler.
2. Shut off the manual gas valve, located downstream of the gas valve, to stop flow of fuel to the boiler.
3. Turn on the boiler. The ignition sequence will start, but the burner will not light.
4. The boiler will lockout after some time. The display screen will turn red and the control will be a solid red alarm; this means the boiler tried to ignite without success. There is one retry before lockout, which is in accordance with ASME CSD-1, latest edition. The ignition system safety device is working properly when the lockout performs as indicated in this step.
5. Clear the lockout condition by selecting <RESET CONTROL> in the red lockout box.
6. Open the manual gas valve to resume fuel supply.

Check the System for Leaks

WARNING

The system must be sealed gas-tight to prevent flue gas spillage and carbon monoxide emissions, which can result in severe personal injury, death, or substantial property damage.

1. Operate the boiler on high fire.
2. Move an inspection mirror around all heat exchanger cover plate joints at the top of the boiler to check for leaks.

Check the System for Leaks, continued

3. Inspect the joints between the condensate dish, vent adapter, and vent pipe.
4. Check for gas-tight seals at every connection and seam of air and vent piping.
5. A leak appears as vapor on the surface of the mirror. In addition, look for signs of weepage or other indications that there may be leakage.
6. If there is any indication of a leak at any joint, shut down the boiler immediately.
 - a. Tighten the retaining screws or nuts if possible. Do not over tighten.
 - b. If tightening the screws or nuts does not correct the issue, disassemble the components where the leak appeared. Use the procedures given in the Maintenance section, starting on [page 103](#).
 - c. When disassembling components, inspect gaskets to see if there is any damage. Replace damaged gaskets.

Contact WM Technologies Technical Services if the problem cannot be address with the information provided in this manual.

Gas Valve Leakage Testing

Refer to the gas valve manufacturer's instructions for the procedure to test the valve. Use the following procedure to turn on the two solenoid valves located on the gas valve one at a time.

1. Turn off power to the boiler.
2. Obtain the gas valve test harness, located in the envelope assembly included with the boiler.
3. Disconnect the gas valve electrical harness.
4. Plug in the gas valve test harness between the gas valve and the gas valve electrical harness.
5. Ensure both test harness rocker switches are in the ON position.

WARNING

DO NOT connect a manometer to the manual or automatic gas valve. The high vacuum from the blower could pull fluid into the gas line, which could damage the gas valves. Failure to comply can result in severe personal injury, death, or substantial property damage.

Figure 72 Ignition sequence timing

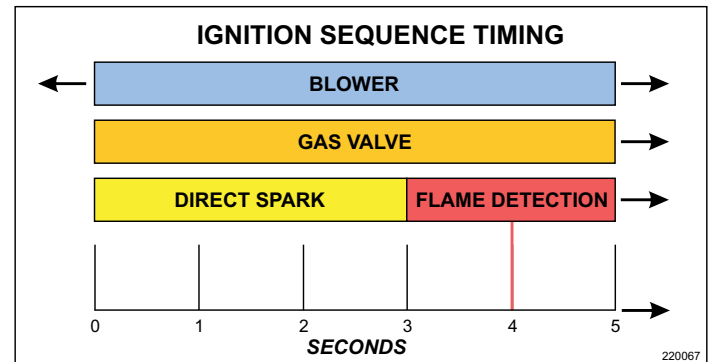

6. Turn on power to the boiler.
7. Give the boiler a call for heat.
8. Verify that the boiler operated through a normal ignition sequence. See [Figure 72](#).
9. Operate each of the gas valve solenoids individually.
 - a. Turn the test harness rocker switches to OFF.
 - b. Turn on one of the rocker switches.
 - c. Provide a call for heat.
 - d. When the gas valve is energized, only one indicator should light, V1 or V2. See [Figure 71, page 99](#).
 - e. Use a piece of tape to label this rocker switch as V1 or V2, depending on which indicator lit up.
 - f. Label the other rocker switch with the name of the other indicator light (V1 or V2).
 - g. Power the boiler on and off. Use the rocker switches to operate solenoid V1 or V2 independently as called for in the gas valve manufacturer's leak test instructions.
10. Once testing is complete, turn power off to the boiler.
11. Disconnect the gas valve test harness, and place it back into the envelope assembly for future use.
12. Reconnect the gas valve electrical harness.

IMPORTANT

The gas valve electrical harness must be reconnected to return the boiler to normal function.

13. Turn on power to the boiler.
14. Operate the boiler through an ignition cycle to ensure proper operation.

Startup Procedure, continued

Verification Check List

- Verified that the control is programmed correctly?
- Verified that the boiler and heat distribution units are filled with water?
- Verified water chemistry per [page 92](#)?
- Automatic vents opened one full turn (if used)?
- Air purged from the system?
- Filled the condensate trap with water?
- Thermostat circuit wiring checked to ensure there are no stray voltages?
- Followed the operating instructions in [Figure 70](#), [page 97](#)?
- Burner flame and combustion verified per [pages 98-99](#)?
- Verified control operation for space heating and DHW (if used) per this manual?
- Tested additional field-installed controls? Verified these controls cause automatic reset or manual lockout as desired?
- Set additional field-installed limit controls to system temperature requirements?
- Adjusted balancing valves and controls to provide the correct temperature to the system per system design?
- Verified that the thermostat heat anticipator is set properly (if available)? See [page 71](#) for requirements.
- For multiple zones, adjusted for correct flow in each zone?
- Cycled boiler with thermostat and DHW aquastat (if installed)? Raised to highest setting and verified the boiler goes through normal startup cycle? Lowered to lowest setting and verified the boiler turns off?
- Measured natural gas input?
- Checked incoming gas pressure as specified on [page 63](#)?
- Observed several operating cycles for proper operation?
- Set room thermostat to desired room temperature?
- If installed, set DHW aquastat to desired DHW storage temperature?
- Reviewed all instructions shipped with this boiler with the owner or maintenance person?
- Filled in the Installation and Service Certificate on [page 146](#)?
- Filled out the warranty registration card and sent it to WM Technologies?
- Return all instructions to the envelope, and either give it to the owner, or place it inside the boiler housing. Instructions must be available for all service and adjustment of the boiler.

SECTION 5

Maintenance

This section is intended to provide maintenance instructions and timing for the boiler.

Section Contents

Maintenance — General	103
Annual Inspection	104
Annual Startup	107

Maintenance — General

⚠WARNING

Turn off power to the boiler before any service operation except as noted otherwise in this manual. Failure to turn off electrical power can cause electrical shock, which can result in severe personal injury or death.

Handling Ceramic Fiber Materials

⚠WARNING

The cover plate components, refractory insulation, and gaskets contain ceramic fiber materials that have been identified as carcinogenic, or possibly carcinogenic, to humans. Avoid breathing in dust. Avoid contact with skin and eyes. Wear long-sleeve, loose-fitting clothing, gloves, and eye protection when working on the boiler. Use a NIOSH certified dust respirator (N95). Failure to comply can result in severe personal injury or death.

Ceramic fibers can be converted to cristobalite in very high temperature applications. The international Agency for Research on Cancer (IARC) has concluded, “Crystalline silica inhaled in the form of quartz or cristobalite from occupational sources is carcinogenic to humans (Group 1).”

Use of an N95 respirator is based on the OSHA requirements for cristobalite at the time this document was written. Other types of respirators may be needed depending on the job site conditions.

Preventative measures include the following:

- Avoid breathing in dust.
- Wear long-sleeved, loose fitting clothing, gloves, and eye protection.
- Use an N95 respirator
- Handle cover plate components, refractory insulation, and gaskets carefully.
- If replacement is necessary, remove the parts and insulation from the boiler and place into a plastic bag for disposal.
- Wash potentially contaminated clothes separately from other clothing. Rinse the clothes washer thoroughly afterwards.

Current NIOSH recommendations can be found on the NIOSH website at www.cdc.gov/niosh/homepage.html. NIOSH approved respirators, manufacturers, and phone numbers are also listed on this website.

NIOSH stated First Aid for contact or irritation:

- Eyes: Irrigate immediately
- Breathing: Fresh air

Perform Startup and Checkout

After any maintenance procedure, verify operation of the boiler. Removing and reinstalling components can change boiler behavior. Follow the complete procedure for boiler and system startup, beginning on [page 92](#).

⚠WARNING

Wiring errors can cause improper and dangerous operation. Label all wires to ensure proper connection. Never jumper (bypass) any device except for momentary testing. Failure to comply can result in severe personal injury, death, or substantial property damage.



Annual Inspection

First-Year Special Inspection

Obtain a Boiler Annual Maintenance Kit (part number 384-000-422) before attempting the first-year inspection to ensure all needed parts are available. This kit includes a heat exchanger cover plate gasket, burner gasket, new ignition electrode, igniter gasket, and a flame sense rod with gasket. See the Parts section starting on [page 131](#) for ordering information. These parts must be on hand when performing the first-year inspection in the event that replacement must be completed.

⚠ WARNING

Failure to replace the items listed above when needed can result in severe personal injury, death, or substantial property damage.

⚠ WARNING

Do not use compressed air to clean the burner. Failure to comply can result in severe personal injury, death, or substantial property damage.

1. No later than 12 months after the boiler is installed, perform a first-year inspection of the boiler. The inspection should include the following specific instructions, in addition to routine annual start-up procedures.
 - a. Inspect the heat exchanger and clean if necessary. See [page 111](#) for access and cleaning procedures.
 - b. Inspect the cover plate insulation and gasket. Replace if not in good condition.
 - c. Remove and clean the burner thoroughly with one of two methods:
 - Vacuum the burner. Be careful not to rub or scrape the fiber mesh.
 - Flush the burner with water. Rinse the burner down. Allow time for the burner to dry completely before reinstalling.

- d. Make sure there is no blockage or accumulation of debris in the burner or burner ports. Replace the burner if necessary.
 - e. Check the burner mesh for tightness.
 - f. Make sure to follow the inspection procedure given on [page 101](#).
 - g. Disconnect the condensate trap and drain lines; inspect, then flush thoroughly. Reinstall and refill the trap per [pages 61](#) and [95](#).
2. Determine any follow-up maintenances and service needs based on the condition of the heat exchanger and condensate lines.
 - a. If the heat exchanger shows substantial fouling, or if the condensate lines show accumulation of sediment, schedule a follow-up service call to perform the first-year inspection again. This service call should be sooner than the normal 12 months between inspections.
 - b. Heavy fouling of the exchanger or condensate lines indicates possible combustion air contamination. Inspect the air inlet area carefully. Remove all possible contaminants. See [page 30](#) for products to avoid.

NOTICE

Corrosion and contamination causes must be eliminated to ensure reliable operation of the boiler and system. Failure to eliminate these causes can result in substantial property damage.

General Inspection Information

The boiler should be inspected and started at the beginning of the heating season annually, only by a qualified service technician.

The maintenance and care of the boiler designated on [page 106](#), and explained on the following pages, must be performed to assure maximum boiler efficiency and reliability.

Inspect any issues reported by the owner and correct before proceeding.

NOTICE

Failure to service and maintain the boiler and system can result in equipment failure.

⚠ WARNING

Do not use solvents to clean any of the boiler components. The components could be damaged, causing unreliable or unsafe operation, which can result in severe personal injury, death, or substantial property damage.

⚠ WARNING

Turn off power to the boiler before any service operation except as noted otherwise in this manual. Failure to turn off electrical power can cause electrical shock, which can result in severe personal injury or death.

Inspect the Boiler Area

1. Verify the boiler area is free of any combustible materials, gasoline, and other flammable vapors and liquids.
2. Verify the air inlet area is free of any contaminants listed on [page 30](#). Remove any contaminants that are present in the boiler intake air vicinity. If the contaminants cannot be removed, reinstall the air and vent lines per this manual.

Inspect the Boiler Interior and Jacket Door Gaskets

1. Remove the jacket door and inspect the interior of the boiler.
2. Visually inspect the jacket door gaskets in front of the cabinet. Make sure all gaskets are in good condition. Replace any damaged gasket.

⚠ WARNING

Jacket door gaskets must be intact and must provide a reliable seal. Failure to comply can result in severe personal injury, death, or substantial property damage.

3. Remove the venturi air inlet silencer and clean if necessary. Reinstall the silencer.
4. Vacuum any sediment from the inside of the boiler and components. Remove any obstructions.

Inspect and Clean the Condensate Trap

1. Inspect the condensate trap. If the trap has accumulated debris, remove the trap and clean.

NOTICE

If removing and reinstalling the trap, see [page 61](#) for more information.

2. Loosen the hose clamps from the condensate trap inlet and outlet connections. Remove trap and flush as needed.
3. Ensure there are no visible cracks or damage to the trap. Make sure the inlet and outlet connections are in good condition.
4. Reinstall the condensate trap.
5. Fill the trap with fresh water by pouring into the flue adapter test port. Continue filling slowly until water begins flowing out of the condensate drain line. Make sure the trap line is unobstructed and flows freely. See [page 95](#) for more information.
6. Verify all the connections are made with no leaks to complete installation.

Inspect All Piping for Leaks

⚠ WARNING

Eliminate all system or boiler leaks. Failure to comply can result in severe personal injury, death, or substantial property damage.

Inspect all water and gas piping. Look for signs of leaking lines. Correct any issues found. See the procedure on [page 63](#) for checking gas lines.

Annual Inspection, continued

Service and Maintenance Schedules

Service Technician <i>(use this manual for instructions)</i>		Owner Maintenance <i>(see the User Manual for instructions)</i>	
Annual Start-up (also see the first-year inspection instructions)	General: <ul style="list-style-type: none"> <input type="checkbox"/> Investigate reported issues. <input type="checkbox"/> Clean the condensate trap and fill with fresh water. <input type="checkbox"/> Check for leaks (water, gas, flue, and condensate). <input type="checkbox"/> Check system water chemistry, inhibitor level, and antifreeze concentration, if used. <input type="checkbox"/> Check boiler relief valve. <input type="checkbox"/> Verify flue and air lines are in good condition and sealed tight. <input type="checkbox"/> Verify operation of the combustion air damper, if used. <input type="checkbox"/> Check system water pressure, system piping, and expansion tank. <input type="checkbox"/> Check ignition electrode and flame sense rods. Inspect, clean, and check spacings. <input type="checkbox"/> Check ignition and ground wiring. <input type="checkbox"/> Check control function and settings: <ul style="list-style-type: none"> • High gas pressure switch • Low gas pressure switch • Low water cut-off • Operating and high limits <input type="checkbox"/> Check wiring and connections. <input type="checkbox"/> Perform startup checkout and performance verification beginning with Startup, Fill the System, page 92. <input type="checkbox"/> Check the high flue pressure switch per page 114. <input type="checkbox"/> Inspect flame for stability and uniformity. <input type="checkbox"/> Check the flame signal. <input type="checkbox"/> Clean the heat exchanger if flue temperature is more than 30°F above return water temperature. <input type="checkbox"/> Check the blower speed settings. 	Daily <ul style="list-style-type: none"> <input type="checkbox"/> Check the boiler area. <input type="checkbox"/> Check air openings. <input type="checkbox"/> Check pressure/temperature gauge. <input type="checkbox"/> Verify the boiler panels are securely in place. 	
	Additional actions if combustion or performance indicate the need: <ul style="list-style-type: none"> <input type="checkbox"/> Clean heat exchanger <input type="checkbox"/> Remove the burner and clean with a vacuum or water flush only. Refer to instructions and warnings on page 110. <input type="checkbox"/> Vacuum the blower. 	Monthly <ul style="list-style-type: none"> <input type="checkbox"/> Check the vent piping. <input type="checkbox"/> Check the air piping. <input type="checkbox"/> Check the relief valve. <input type="checkbox"/> Check the condensate drain system. <input type="checkbox"/> Check the air vents. 	
	Review: <ul style="list-style-type: none"> <input type="checkbox"/> Review with the owner 	Periodically <ul style="list-style-type: none"> <input type="checkbox"/> Test low water cut-off by pressing the test button. 	
		Every 6 Months <ul style="list-style-type: none"> <input type="checkbox"/> Check the boiler gas and water piping. <input type="checkbox"/> Operate the relief valve. 	
		End of Season <ul style="list-style-type: none"> <input type="checkbox"/> Shut down the boiler (unless the boiler is used for domestic water). 	

⚠ WARNING

Follow the service and maintenance procedures given throughout this manual and other literature shipped with the boiler. Failure to perform service and maintenance can cause damage to the boiler or system. Failure to follow the directions in this manual and component literature can result in severe personal injury, death, or substantial property damage.

Print or photocopy this page to keep an annual record



Annual Startup

Check Air Openings

1. Verify that combustion and ventilation air openings to the boiler room and building are open and unobstructed.
2. Check operation and wiring of automatic combustion air dampers, if used.
3. Verify the boiler vent discharge and air inlet are clean and free of obstructions.
4.
 - b. Make sure the vents do not leak.
 - c. Replace any leaking vents.
5. Check the system water chemistry. See [page 92](#).

NOTICE

Failure to reinstall or repair a combustion air damper can result in nuisance shut downs or substantial property damage.

Flue Vent System and Air Piping

1. Visually inspect the entire flue gas venting system, and air piping if installed, for blockage, deterioration, or leakage.
2. Inspect both 3-in-1 adapters. Ensure the gaskets are in good condition and properly seated between the condensate dish and the adapters.
3. Repair any joints that show signs of leakage in accordance with vent manufacturer's instructions.
4. When air is ducted to the boiler, verify that the air inlet pipe is connected and properly sealed.

⚠ WARNING

Failure to inspect for the above conditions and have them repaired can result in severe personal injury or death.

Check the Water System

1. Verify all system components are correctly installed and operational.
2. Check the cold fill pressure for the system, and verify it is correct. Refer to the minimum water pressure specifications in [Table 5, page 21](#).
3. Watch the system pressure as the boiler heats up during testing to ensure the pressure does not rise too high. Excessive pressure rise indicates an issue with the expansion tank, such as incorrect sizing or other performance issues.
4. Inspect automatic air vents and air separators.
 - a. Remove the air vent caps and briefly press the push valve to flush the vent. Reinstall the caps.
5.
 1. Remove and inspect the valve and its components.
 - a. Ensure the valve has no corrosion, and make sure the valve and discharge line have not been tampered with or altered.
 - b. Water conditions or some natural occurring conditions may corrode the valve or its components over time, making the valve inoperative.
 - c. If the relief valve weeps or will not seat properly, replace the valve. Ensure the reason for the valve weeping is the valve itself, and not the over-pressurization of the system due to a waterlogging or under-sized expansion tank.
 2. Operate the safety relief valve lever.
 - a. If no water flows when operating the lever, the valve is inoperative and must be replaced.
 3. If relief valve replacement is necessary, shut down the boiler until a new relief valve has been installed by a licensed contractor or inspection agency.

⚠ WARNING

Failure to reinspect the boiler relief valve and its components as directed can cause unsafe pressure buildup, which can result in severe personal injury, death, or substantial property damage.

Annual Startup, continued

Check the Expansion Tank

Expansion tanks provide space for water to move in and out as the heating system water expands or contracts due to temperature increases or decreases. Tanks may be open, closed, diaphragm, or bladder type.

Open-type: Located above the highest radiator or baseboard unit, usually in the attic or a closet. This type has a gauge glass and overflow pipe to a drain.

Closed-type: Welded gas tight and located above the boiler. This tank is partially filled with water, leaving an air cushion for expansion.

- Make sure a closed-type tank is fitted with a tank fitting, such as the B&G Airtrol. This fitting reduces gravity circulation of air-saturated tank water back to the system. It also prevents the air from bubbling up through the water as it returns from the system.
- Do not use automatic air vents in systems with closed-type tanks. The air will escape from the system instead of returning to the tank. Eventually, the tank will waterlog and no longer control pressurization. The boiler relief valve will weep frequently.

Diaphragm- or bladder-type: Welded gas tight with a rubber membrane to separate the tank pressurizing air and the water. This tank may be located at any point in the system, but it is most often found near the boiler.

- Systems with a diaphragm- or bladder-type expansion tank require at least one automatic air vent, preferably located on top of an air eliminator, as shown in this manual.

If the relief valve tends to weep frequently, the expansion tank may be waterlogged or undersized.

- Closed-type: The tank is most likely waterlogged. Install a tank fitting if not already installed. Check the fill level per the fitting manufacturer's instructions. If the fill level is correct, check the tank size against the manufacturer's instructions. Replace with a larger tank if necessary.
- Diaphragm- or bladder-type: Check that the tank size is large enough for the system. If the tank is too small, add one or more additional tanks as necessary to provide sufficient expansion. If the tank size is large enough, remove the tank from the system and check charge pressure. If the tank will not hold pressure, the membrane has been damaged, and the tank needs to be replaced.

Inspect the Ignition Electrode and Wiring

See the figures to the right for the references below.

1. Shut off power to the boiler.
2. Close the external manual gas valve to ensure there is no gas flow to the unit.
3. Allow time for the boiler to cool to room temperature if it has been firing.
4. Disconnect the ground wire and ignition cable connected to the ignition electrode (item 8).
5. Use a 3 mm Allen wrench to remove the two screws securing the electrode to the heat exchanger cover plate (item 5). Carefully remove the igniter with flame sense assembly.
6. Discard the ignition electrode gasket.
7. Inspect the electrode and ceramic insulator.
 - a. Remove any white oxides that have accumulated on the ignition electrode using steel wool.
 - b. Clean the gasket surfaces on the igniter assembly flange and on the mating surface of the heat exchanger cover plate.
 - c. If the igniter is cracked or damage, or if it cannot be satisfactorily cleaned, replace it.
8. Slide the new gasket onto the ignition electrode. Set the assembly aside for later installation.
9. Check that the ignition cable electrical resistance is between 950 and 1050 ohms. Replace the cable if not acceptable.
10. Verify that all wiring is in good condition and securely attached.
11. Inspect the boiler ground wire from the heat exchanger access cover to the ground terminal screw in the control tray.
 - a. Check that the resistance is 0 ohms.
 - b. Check the ground continuity of the wiring using a continuity meter.
 - c. Replace the ground wires if the results are not satisfactory.
12. The igniter rods should be parallel, and the spark gap should be 3.5 mm.

Figure 73 Boiler interior assembled view

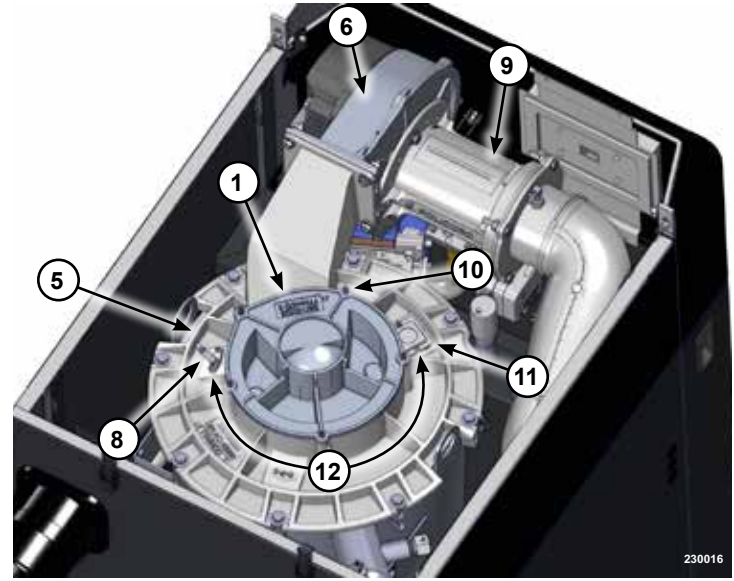
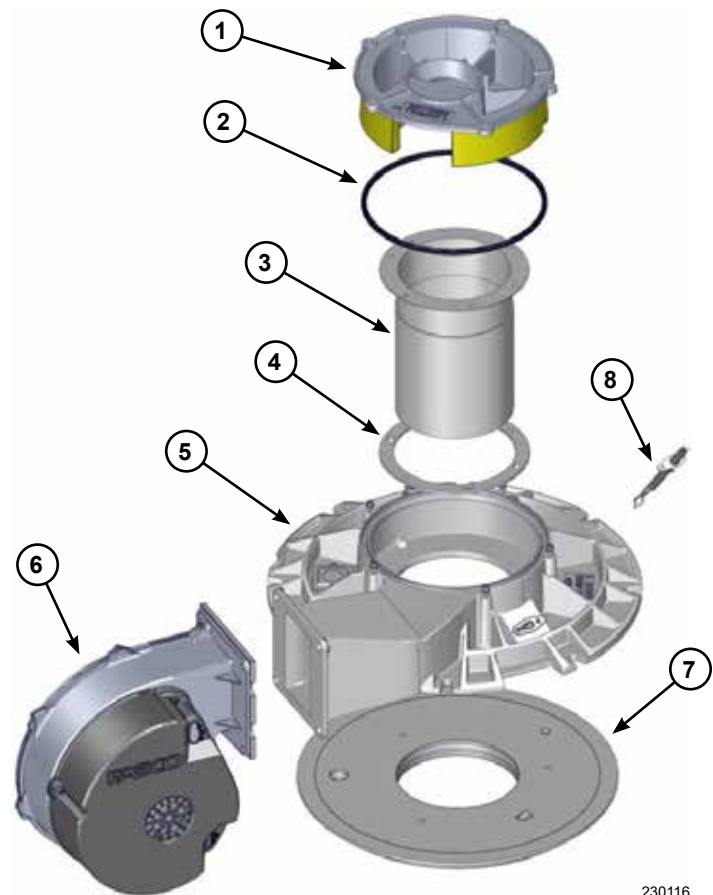

Figure 74 Boiler interior exploded view



Legend – Figure 73 and Figure 74		
1. Burner access hatch	5. Cover plate	9. Venturi
2. Burner access hatch seal	6. Blower	10. M5 bolts (x5)
3. Burner	7. Cover plate insulation with integrated seal.	11. Sight glass
4. Ceramic fiber burner gasket	8. Ignition electrode (igniter)	12. M4 bolts - two each for the igniter and sight glass

Annual Startup, continued

Inspect and Clean the Burner

⚠ WARNING

The boiler contains ceramic fiber materials. Use care when handling these materials per instructions on [page 103](#). Failure to comply can result in severe personal injury or death.

See the figures on [page 109](#) for the references below.

1. Use an 8 mm wrench or socket to remove the five M5 bolts (item 11) that secure the burner access hatch (item 1) to the heat exchanger cover plate (item 5).
2. Remove the burner access hatch.
3. Use a 10 mm socket or wrench to remove the six M5 bolts securing the burner.
4. Use caution when removing the burner (item 3). Pull it directly up and out.

NOTICE

DO NOT angle the burner when removing it. Angling the burner could cause it to strike and damage the insulation.

NOTICE

If the insulation has been damaged it must be replaced. If fragments from the insulation have fallen into the heat exchanger, the heat exchanger must be thoroughly cleaned.

5. Remove and discard the burner gasket (item 4).
6. Inspect the burner access hatch seal (item 2). If the seal is damaged in any way, discard and use a new seal during reassembly.

⚠ WARNING

Replace damaged or stretched gaskets before placing the boiler back into operation. Failure to comply can result in severe personal injury, death, or substantial property damage.

7. Inspect the interior of the burner. Brush and vacuum the interior if needed to remove lint or sediment. Alternatively, clean with a water spray from inside the burner.

8. Inspect the burner exterior. It must be in good condition with no visible damage.
9. Clean the underside of the burner flange with a soft brush to remove any remaining gasket fragments.
10. Set the burner aside for later installation. The burner must be completely dry before reinstalling.

Inspect the Combustion Chamber

1. Use a trouble light and inspection mirror to inspect the interior of the heat exchanger through the burner opening in the cover plate.
2. Make sure there is no debris inside the heat exchanger.
3. Use the mirror to check the condition of the cover plate insulation with the integrated seal that is attached to the bottom of the heat exchanger cover plate. It must be in good condition with no indication of damage or sagging. Ensure the insulation is tightly installed on the cover plate and the bolts are secure.
4. Make sure there are no signs of overheating or flue gas leakage.
5. If visual inspection of the heat exchanger indicates the need for cleaning, remove the heat exchanger cover plate and fully inspect and clean the interior. Follow the procedures on [page 111](#).
6. Replace any parts for any components that may be damaged or show signs of leaking.

⚠ WARNING

Damaged or leaking components must be replaced. Failure to comply can result in severe personal injury, death, or substantial property damage.

Cleaning the Heat Exchanger - Water Side

In order for the efficiency of boilers to increase beyond the condensing limit, new materials have been introduced for the heat exchanger, including stainless steel. Stainless steel has excellent heat transfer characteristics. It is also light in weight.

The materials now used require cleaning solutions that differ from those used in conventional cast iron and steel boilers. WM Technologies recommends Sentinel X400 for cleaning the boiler.

WARNING

One common cleaning method that CANNOT be used with systems containing stainless steel is a solution of trisodium phosphate, commonly referred to as TSP. Failure to comply can result in severe personal injury, death, or substantial property damage.

Cleaning the Heat Exchanger - Flue Side

1. Shut down the boiler.
 - a. Follow the instructions under To Turn Off Gas to the Appliance in [Figure 70, page 97](#).
 - b. Do not drain the boiler unless it will be exposed to freezing temperatures. If using freeze prevention fluid in the system, do not drain.
2. Close the external manual gas valve to ensure there is no gas flow to the unit.
3. Safely bleed the excess gas from between the external manual shutoff and the gas valve.
4. Allow time for the boiler to cool to room temperature if it has been in operation.

Cover plate removal:

5. Before removing the cover plate, refer to the instructions on [page 110](#) for removing the burner.
6. Disconnect the two wire harnesses connected to the blower.
7. Using two pipe wrenches, remove the gas flex line from the inlet pipe for the automatic gas valve.

8. Disconnect the blower from the cover plate with a 13 mm wrench or socket. Carefully lift the blower, venturi, and gas valve assembly out of the boiler and set aside.
9. Using a 5 mm Allen wrench, loosen all bolts holding the cover plate to the heat exchanger.
10. Remove the cover plate with insulation and set it aside.

Water spray the heat exchanger:

11. Disconnect the condensate trap at the bottom of the heat exchanger so debris will not clog the trap.
 - a. Loosen the hose clamp that secures the trap to the condensate drain. Slide the trap off and move it out of the way to expose the drain.
 - b. Place a pan under the condensate trap outlet to collect water and debris.
12. Use the combustion chamber opening to spray water down into the heat exchanger tubes. Continue spraying until all debris in the tubes has been flushed into the base.
13. Spray water through the condensate line to thoroughly clean it.
14. Remove the pan and reinstall the condensate line.
15. Do not spray the burner or cover plate insulation. Avoid getting the burner or cover plate wet.

NOTICE

If the burner or cover plate do get wet, allow them to dry completely before reinstalling into the boiler. Do not operate the boiler if these components are wet.

Annual Startup, continued

Reinstalling All Components

See the figures on [page 109](#), Figure 75, and [Figure 76, page 113](#) for the references below.

1. Place the cover plate onto the heat exchanger. Ensure the blower flange is facing the front of the boiler and square.
2. Install all bolts finger-tight from the heat exchanger to the cover plate.
3. Tighten all bolts in a star pattern with a 5 mm Allen wrench to secure the cover plate to the heat exchanger. Do not exceed 88 in-lbs (9.94 Nm).
4. Carefully place the blower, venturi, and gas valve assembly into the boiler.
 - a. Attach the blower to the cover plate and install the four nuts finger-tight to secure the assembly. Torque each nut to 88 in-lbs (9.94 Nm) using a 13 mm wrench.
 - b. Reinstall the flex gas line to the inlet pipe using two pipe wrenches.
 - c. Reinstall the harnesses to the blower.
5. Reinstall the burner (item 3).
 - a. Insert a new burner gasket (item 4) into the heat exchanger cover plate (item 5).
 - b. Insert the burner into position. Use a torque wrench to tighten the six bolts in a star pattern. Do not exceed 44 in-lbs (5 Nm).
6. Insert the burner access hatch seal into the heat exchanger cover plate, and the burner access cover into position. Use a torque wrench to tighten the five bolts (item 11). Do not exceed 44 in-lbs (5 Nm).
7. Reinstall the igniter electrode assembly (item 8).
 - a. Insert the ignition electrode into the cover plate opening with the gasket in position.
 - b. Reinstall the two socket head screws finger tight. Use a torque wrench to tighten the screws. Do not exceed 20 in-lbs (2.25 Nm).
 - c. Reattach the igniter cable and ground wire to the ignition electrode assembly.
8. Reinstall the condensate trap assembly to the heat exchanger drain. Tighten the hose clamp to secure the trap to the drain.

Figure 75 Cover plate and gasket installation

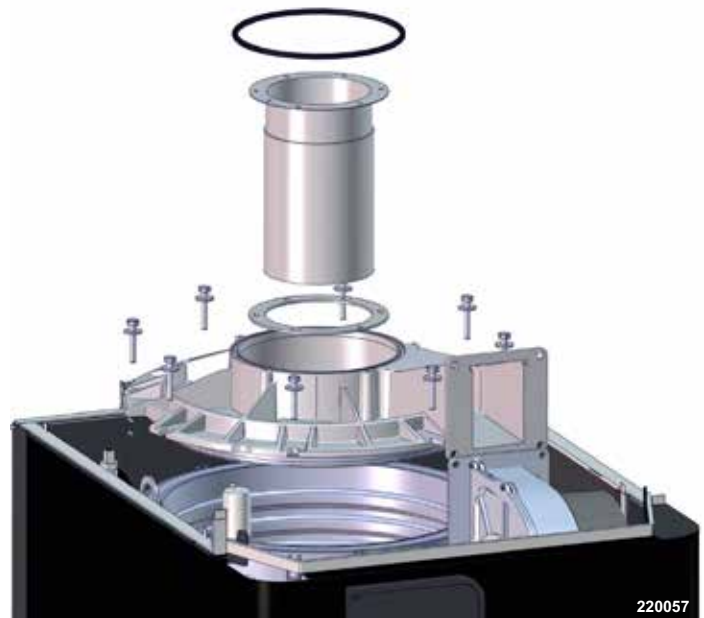

NOTICE

Use a torque wrench when tightening the bolts and screws. Do not exceed the stated torque or damage may occur.

WARNING

Check the seal of the ignition electrode, igniter gasket, and cover plate to ensure they are gas-tight. Failure to properly seal these parts could cause a gas leak or carbon monoxide emissions, which can result in severe personal injury, death, or substantial property damage.

Figure 76 Cover plate nut tightening sequences

- Gradually tighten the cover plate and burner plate access bolts in the sequence shown in the illustration.
- Burner torque: 44 in-lbs (5 Nm), 10 mm wrench
- Burner access plate torque: 44 in-lbs (5 Nm), 4 mm Allen wrench
- Cover plate torque: 88 in-lbs (9.94 Nm), 5 mm Allen wrench

⚠ WARNING

Tighten the bolts as specified. If the tightening is not done properly, the cover plate could buckle and allow a flue gas leakage, which can result in severe personal injury, death, or substantial property damage.

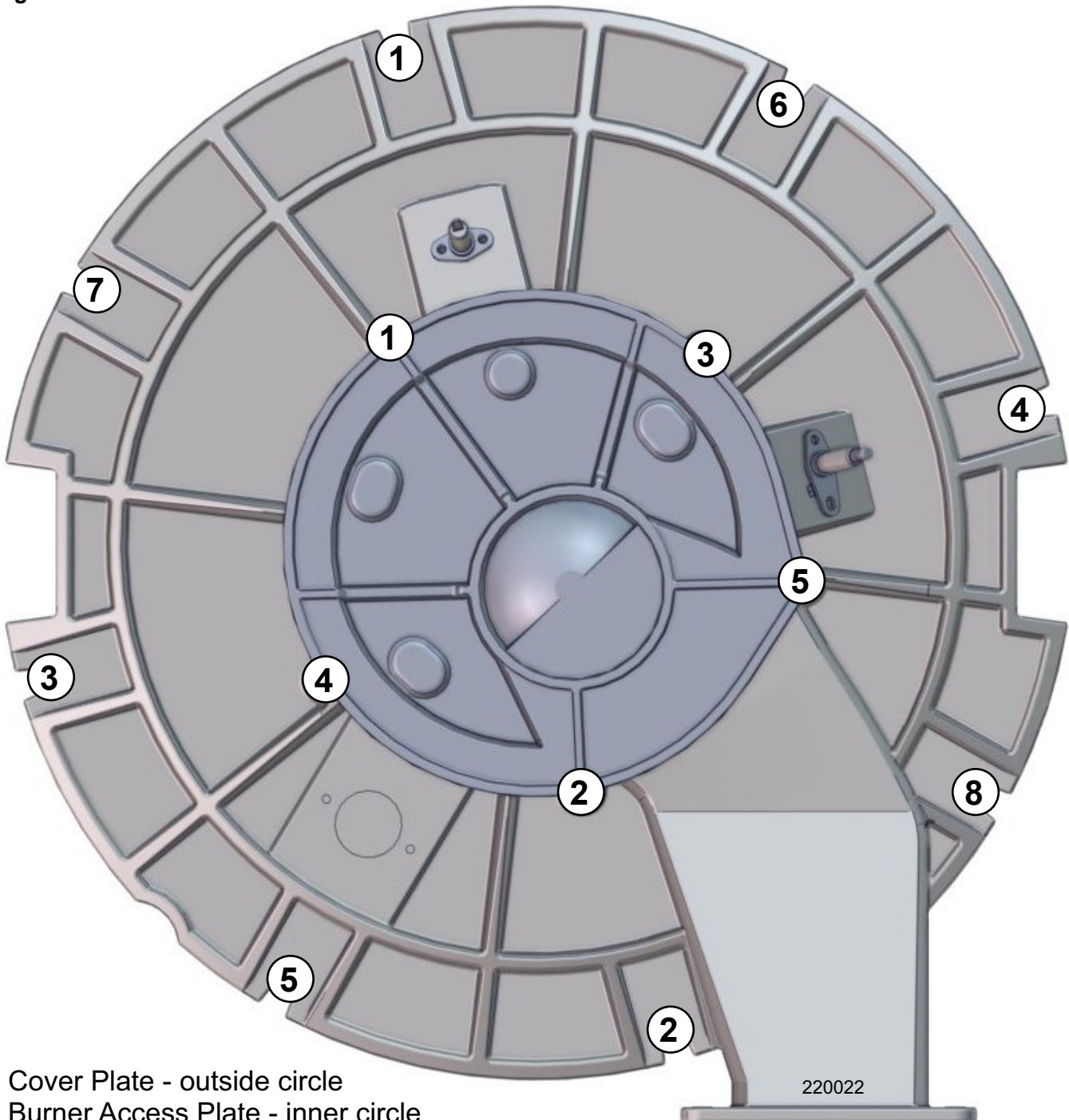

Cover Plate - outside circle
Burner Access Plate - inner circle

Annual Startup, continued

Inspecting the High Flue Pressure Switch

Ensure the wire connects on the pressure switch are properly connected and the tubes are secured to the pressure ports. Inspect the tubes for any signs of damage or debris. Replace if necessary.

1. After checking the control settings, disconnect the tube connection with the condensate dish.
2. Gently blow on the tube until the high flue pressure switch opens and the control displays a lockout error.
3. Clear the lockout on the control. Confirm that the lockout does not reappear.
4. Securely reconnect the tube connection with the condensate dish.

Replacing the Flue Pressure Switch

1. Disconnect the tube on the tap of the flue pressure switch. See Figure 77.
2. Disconnect the two wires running to the switch.
3. Remove the two screws holding the flue pressure switch to the vertical support.
4. Install the new flue pressure switch with two new screws.
5. Reconnect the two wires to the switch.

Check Boiler Wiring and Control Settings

1. Inspect all boiler wiring. Make sure the wires are in good condition and securely attached.
2. Verify that all connectors are securely inserted.
3. Verify that the ground wires are connected to the jacket right side and the control tray cover.
4. Use the control display to navigate through all settings. Adjust the settings if necessary.
5. Check the settings of any external limit controls. Adjust as necessary per the system design.

Perform Startup and Checks

1. Start the boiler and perform checks and tests specified in this manual.
2. Verify the cold fill pressure is correct and the operating pressure does not go too high. Adjust the water pressure and expansion tank charge pressure as necessary.
3. Complete the Verification Check List on [page 102](#).

Figure 77 Pressure switch connection

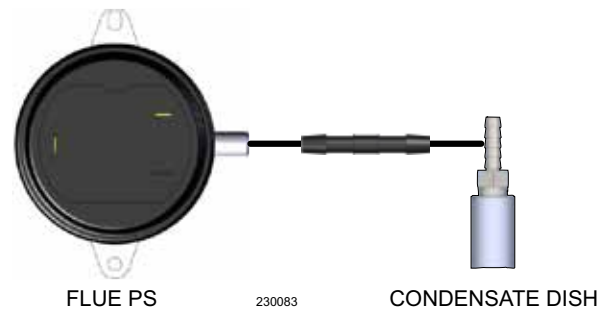

⚠ WARNING

Failure to follow the provided procedures can cause a gas, air, or exhaust gas leak, which can result in severe personal injury, death, or substantial property damage.

Low Water Cut-Off Test

The boiler is equipped with an LWCO integrated in the Boiler Out sensor. The position of this sensor on the heat exchanger is designed to detect the presence of water at the highest location in the boiler. The LWCO sensor is connected to the control on connector J9.

Test method 1: Press and hold the gray LWCO test button below the **J8 and J9** connectors, for at least 5 seconds. See [Figure 8, page 19](#) for button location.

Test method 2: Turn off the boiler, then turn off the circulating pump (if applicable). Isolate the boiler from the system. Drain the water level below the LWCO sensor. Turn on the boiler. It should not operate and should have a Low Water fault.

Test result (both methods): A manual lockout reset error display LOW WATER on the display touchscreen should occur.

If water was emptied, turn off the boiler. Return the system to normal operation by refilling with water, restarting the circulating pump (if applicable), and then turning on the boiler. Reset the boiler on the display touchscreen by pressing the Reset button and following on-screen instructions.

Check the Burner Flame

WARNING

The boiler contains ceramic fiber materials. Use care when handling these materials per instructions on [page 103](#). Failure to comply can result in severe personal injury or death.

1. Inspect the burner flame through the observation window using the procedure on [pages 98-99](#).
2. If the flame is unsatisfactory at high or low fire, check the combustion values. If the combustion is properly adjusted, turn off the boiler. Allow it to cool down.
3. Remove the burner and clean it thoroughly using a vacuum cleaner or water flush. To access the burner, follow the procedure beginning on [page 110](#).
 - a. Vacuum method - Be careful not to rub or scrape the fiber mesh.
 - b. Water flush method - Rinse the burner down. Allow the burner to dry completely before reinstalling.
4. When removing the burner, the burner gasket must be replaced. Follow all instructions on [page 112](#) to reinstall all components.
5. Restart the boiler and inspect the flame again at high and low fire.
6. If the flame is still not acceptable, check the combustion values again.
7. If the combustion cannot be properly adjusted, obtain a replacement burner. See the Parts section starting on [page 131](#) for ordering information.

Check the Flame Signal

The control has three distinct flame signal thresholds that it uses to operate the boiler safely and reliably.

- **Boost:** The highest flame signal threshold. When the flame signal drops below this value, the control takes action to boost or increase the flame sense value by changing how the boiler is operating.
- **Shutdown:** This is the intermediate flame signal threshold. If the control senses a flame quality below this value, it will deenergize the gas valve, extinguishing the flame. The boiler will then proceed through its normal operating process of purging and attempting another ignition if the demand is still active.
- **Proof of Flame:** The lowest flame signal threshold. This is the flame signal value that indicates there has been a successful ignition.

Table 17 Flame signal values

Flame Signal Values for SVF 500/600 Boilers			
Gas Type	Boost	Shutdown	Proof of Flame
Natural Gas	3.4	3.0	0.8
Propane	3.4	3.0	0.8

IMPORTANT

When the flame signal wire is routed within 3" of the ignition cable, and the boiler is in an ignition sequence, the ignition cable may cause noise in the flame signal transmission; this will result in a false flame signal value.

1. Check the flame signal at both high and low fire.
 - a. Press the <Home> button, then press and hold the WM logo until the Contractor menu comes up.
 - b. Press the <Diagnostics> button, followed by the <Manual Test Mode> button.
 - c. When the boiler is not in ignition or running states, the flame signal should read 0.
 - d. During ignition or running states, a strong flame signal should read between 4-7.
2. The flame signal value must be greater than 3.7 for NG and 3.2 for LP for any operation.
 - a. If the flame signal drops below this level, the control will enter Flame Boost mode, which raises the modulation rate in an attempt to strengthen the flame signal.
 - b. The flame signal value must be greater than 0.8 to pass presence of flame, and greater than 3.7 for NG and 3.2 for LP to pass quality of flame checks.
3. A low flame signal may indicate a fouled igniter.
 - a. See instructions on [page 109](#) to remove and inspect the igniter with flame sense.
 - b. If required, clean the igniter.
 - c. Check the combustion values.
 - d. If cleaning the igniter does not improve low flame sense, but the flame sense wiring is in good condition and ground continuity is satisfactory, replace the igniter.
4. If flame sense remains low after igniter replacement:
 - a. Inspect the vent and air piping.
 - b. Inspect the heat exchanger. See the procedure for removal and installation on [pages 111-113](#).
 - c. Clean the heat exchanger as described in this manual as necessary.

Annual Startup, continued

Check the Flue Gas Temperature

1. Set the boiler to high fire.
2. Adjust the control display to view flue gas temperature and boiler return temperature.
3. The flue gas temperature should be no more than 50°F higher than the boiler return temperature.
 - a. If the flue temperature is higher than this, shut down the boiler. Allow it to cool down.
 - b. Follow the procedure starting on [page 111](#) to clean the heat exchanger.

Check Blower Speeds

For installations at altitudes above 2,000 ft., make sure the control is set up for the correct blower RPM for low fire and ignition rates to compensate for high altitude conditions.

1. Use the control display to navigate to Manual Control Firing Rate. See the SVF Advanced Manual (part number 550-100-207) for navigation instructions and the complete diagnostics menu.
2. Set the firing rate to 0% (low fire). Write down the blower RPM value shown. Compare it to the value in [Table 18, page 117](#). The value should be no less than the minimum setting, and no higher than the ignition factory setting listed. Low fire rate (% of max rate) is adjusted in the setup menu.
3. Set the firing rate to 100% (high fire).
4. Write down the blower RPM value. It should be within 200 RPM of the value given in [Table 18, page 117](#).
5. If any of the values are outside the ranges listed in the previous steps, contact WM Technologies for technical assistance.

High Altitude

The boiler will automatically derate the BTU values listed in [Table 18, page 117](#) at altitudes over 2,000 ft. above sea level.

In the USA, input rates are derated 4% for each 1,000 ft. above sea level after 2,000 ft.. This is in accordance with the National Fuel Gas Code – ANSI Z223.1/NFPA 54, latest edition.

IMPORTANT

For elevations above 11,000 ft. in the USA, please contact WM Technologies Technical Support for details.

In Canada, input rates are derated 10% for altitudes of 2,000 ft. to 4,500 ft. above sea level. This is in accordance with the Natural Gas and Propane Installation Code – CAN/CSA B149.1. Please use the appropriate fan speed settings for high altitude provided in this manual.

For elevation beyond 4,500 ft. in Canada, please consult local codes and Provincial Authorities having jurisdiction.

Table 18 Natural gas (NG) and propane (LP) firing rates and corresponding blower speeds (low fire and high fire), for altitudes up to 2,000 ft. (default settings), and for high altitudes (above 2,000 ft.).

Low Fire													
Model and Fuel Type		500 NG			500 LP			600 NG			600 LP		
Altitude (ft.)	%	RPM	BTU/hr	CO ₂	RPM	BTU/hr	CO ₂	RPM	BTU/hr	CO ₂	RPM	BTU/hr	CO ₂
0-2,000	10%	1090	50000	9.00	1000	50000	10.00	1090	50000	9.00	1000	50000	10.00
3,000	10%	1120	50000	9.00	1060	50000	10.00	1120	50000	9.00	1060	50000	10.00
4,000	10%	1160	50000	9.00	1110	50000	10.00	1160	50000	9.00	1110	50000	10.00
5,000	10%	1190	50000	9.00	1170	50000	10.00	1190	50000	9.00	1170	50000	10.00
6,000	10%	1220	50000	9.00	1220	50000	10.00	1220	50000	9.00	1220	50000	10.00
7,000	10%	1270	50000	9.00	1270	50000	10.00	1270	50000	9.00	1270	50000	10.00
8,000	10%	1310	50000	9.00	1310	50000	10.00	1310	50000	9.00	1310	50000	10.00
9,000	10%	1350	50000	9.00	1360	50000	10.00	1350	50000	9.00	1360	50000	10.00
10,000	10%	1390	50000	9.00	1400	50000	10.00	1390	50000	9.00	1400	50000	10.00
11,000	10%	1430	50000	9.00	1440	50000	10.00	1430	50000	9.00	1440	50000	10.00
High Fire (Max setting is necessary to achieve 100% rate in some conditions)													
Model and Fuel Type		500 NG			500 LP			600 NG			600 LP		
Altitude (ft.)	%	RPM (max setting)	BTU/hr	CO ₂	RPM (max setting)	BTU/hr	CO ₂	RPM (max setting)	BTU/hr	CO ₂	RPM (max setting)	BTU/hr	CO ₂
0-2,000	100%	5200	500000	9.50	5300	500000	10.50	6100	600000	9.50	6250	600000	10.50
3,000	100%	5200	440000	9.50	5300	440000	10.50	6100	528000	9.50	6250	528000	10.50
4,000	100%	5200	420000	9.50	5300	420000	10.50	6100	504000	9.50	6250	504000	10.50
5,000	100%	5200	400000	9.50	5300	400000	10.50	6100	480000	9.50	6250	480000	10.50
6,000	100%	5200	380000	9.50	5300	380000	10.25	6100	456000	9.50	6250	456000	10.25
7,000	100%	5200	360000	9.50	5300	360000	10.25	6100	432000	9.50	6250	432000	10.25
8,000	100%	5200	340000	9.50	5300	340000	10.25	6100	408000	9.50	6250	408000	10.25
9,000	100%	5200	320000	9.50	5300	320000	10.25	6100	384000	9.50	6250	384000	10.25
10,000	100%	5200	300000	9.50	5300	300000	10.25	6100	360000	9.50	6250	360000	10.25
11,000	100%	5200	280000	9.50	5300	280000	10.25	6100	336000	9.50	6250	336000	10.25
Ignition RPM													
Altitude (ft.)	500 NG			500 LP			600 NG			600 LP			
0-2,000	3500			3500			3500			3500			
3,000	3690			3690			3690			3690			
4,000	3870			3880			3870			3880			
5,000	4060			4070			4060			4070			
6,000	4230			4240			4230			4240			
7,000	4380			4390			4380			4390			
8,000	4540			4540			4540			4540			
9,000	4690			4700			4690			4700			
10,000	4850			4850			4850			4850			
11,000	5000			5000			5000			5000			



Annual Startup, continued

Manual Test Mode

Single Boiler:

1. Navigate to Manual Test Mode screen under the Diagnostics menu. See [Figure 62, page 87](#).
2. If the boiler is not in operation, generate a call for heat and wait until the burner is lit and begins modulating the blower motor.
3. Press <EDIT> and select the desired force rate. The rate will be forced to that setting for 30 minutes. Manual Test Mode resets at the end of the heating demand. If timeout happens, boiler will revert to AUTO, but will keep running if demand exist.

Multiple Boilers:

1. Generate a call for heat on a Network Priority or a Local Priority.
 - a. Local Priority allows the force rate only on the boiler with the call for heat. Follow the single boiler procedure above.
 - b. Network Priority allows the force rate on any boiler in the network. Follow the procedure outlined in the next steps.
2. On the master boiler, navigate to the Manual Control Firing Rate screen from the Manual Test Mode button on the Diagnostics screen. Select the boiler being tested.
3. The Run Manual Test On screen will automatically appear on the selected boiler. On the selected boiler's control, press <ENTER> and select the desired force rate (high, medium, or low).

NOTICE

When forcing a rate on a Network Priority call, only boilers running Local Priority calls will remain in operation. All other boilers on the networks will not fire until the manual test has ended. Ensure that critical applications remain heated. Long periods of low heating can cause property damage.

4. The selected boiler will run at the forced rate until it is either returned to AUTO, or until 30 minutes of inactivity on the master control. To return the rate to AUTO, select <END MANUAL TEST> on the master control's Run Manual Test On screen.
5. To test the next boiler, return to the master and select the next boiler to test.

Reinstall the Jacket Door After Servicing

Reinstall the boiler jacket door after startup or servicing. The boiler front door, side panel, and top panel must all be securely fastened to the boiler to prevent the boiler from drawing air from inside the boiler room.

▲WARNING

Ensure the boiler jacket door is closed and securely fastened after startup or any servicing. Failure to comply can result in severe personal injury or death.

Review with the Owner

1. Review the User Manual with the owner.
2. Emphasize the need to follow the maintenance schedule.
3. Remind the owner of the need to call a licensed contractor should the boiler or system exhibit any unusual behavior.
4. Remind the owner to follow the proper shutdown procedure, and to schedule an annual startup at the beginning of the next heating season.

SECTION 6

Troubleshooting

This section is intended to provide solutions by troubleshooting various issues with the boiler. See the SVF Advanced Manual for complete information.

Section Contents

Troubleshooting — General	119
Diagnosing Boiler Issues	119
Errors and Lockouts	122

Troubleshooting — General

Always turn power off to the boiler before servicing and making connections. The boiler ON/OFF switch does not turn off all power to the boiler. Internal wiring is still powered when the switch is in the off position.

⚠WARNING

Turn off all power to the boiler when servicing. Failure to comply can cause electrical surges or electrical shock, which can result in severe personal injury, death, or substantial property damage.

⚠WARNING

Wiring errors can cause improper and dangerous operation. Label all wires to ensure proper connection. Never jumper (bypass) any device except for momentary testing. Failure to comply can result in severe personal injury, death, or substantial property damage.

If assistance is required, please complete the Installation and Service Certificate on [page 146](#) before calling WM Technologies Technical Services. The CP number can be found on the boiler top jacket panel next to the air inlet connection.

Diagnosing Boiler Issues

Checking the Boiler

Check the following items first when servicing the boiler.

1. Check for 120 Vac (minimum 102 Vac to maximum 132 Vac) to boiler.
2. Make sure the thermostat is calling for heat and the contacts are closed. Check for 24 Vac between the thermostat wire nuts and ground.
3. Make sure all external limit controls are either installed and closed, or have temporary jumpers for testing.
4. Make sure that connectors to the control are securely plugged in at the module and originating control.
5. Check the gas pressures. See the Gas Piping section starting on [page 62](#) for values.

Diagnosing Boiler Issues, continued

Checking the Control Fuses

WARNING

Do not jumper fuses or replace with any fuse except as specified. Failure to comply could result in severe personal injury, death, or substantial property damage.

IMPORTANT

Always check control fuses before replacing the control or any major components. If one of these fuses is blown, it can prevent the control or other components from operating.

1. Turn off power to the boiler at the external line switch.
2. Remove the control access door.
3. Remove and inspect the seven fuses (Items 1, 2, and 3, Figure 78). If necessary, replace one or more of the fuses:
 - a. Low voltage circuit fuse (Item 1) is a 3-amp 24 Vac fast-blow (Littelfuse 0287003).
 - b. Line voltage circuit fuses (Item 2) are 2.5-amp 120 Vac fast-blow (Littelfuse 032602.5).
 - c. Line voltage circuit fuses (Item 3) are 4-amp 120 Vac fast-blow (Littelfuse 314004).
4. Reinstall the control access cover.

Figure 78 Control fuses

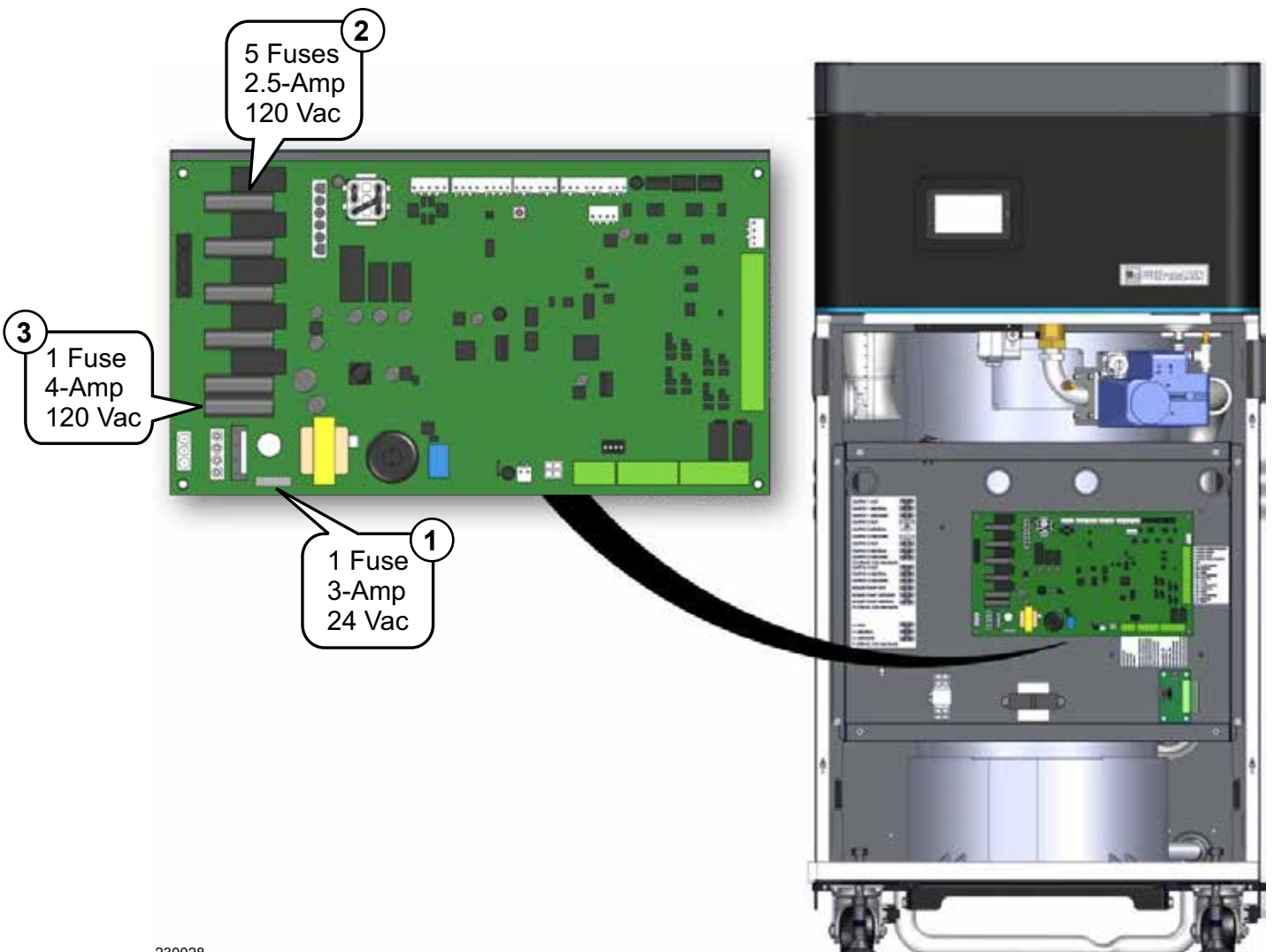

230028

Checking the In-Line Fuses

1. Turn off power to the boiler at the external line switch.
2. Remove the control access door.
3. Remove control tray panel to reach blower in-line fuse holders. Two holders are present in this boiler.
4. Carefully twist the top of the blower fuse holder. The holder is under tension; do not allow parts to spring away. See Figure 79.
5. Remove and inspect each fuse.
 - a. One in-line fuse is a 5-amp, 250 Vac rated 1-1/4" x 1/4" fuse.
 - b. The second in-line fuse is a 15-amp, 250 Vac rated 1-1/4" x 1/4" fuse.
 - c. Replace if necessary.

IMPORTANT

When replacing these fuses, the user **MUST** reinstall the correct size fuse into the correct location. Failure to correctly install the fuses could cause the smaller fuse to blow and shut down the boiler. Fuse holders are marked with fuse information.

Checking the Temperature Sensors

1. The boiler temperature sensors, Boiler In, Boiler Out, Flue, Outdoor, and System Supply/Return, are all resistance-type devices. Table 19 shows the correct values for sensors at various temperatures. For dual sensors, the temperature difference between the sensors must be less than 10°F.
2. Use the resistance values at 32°F, 60°F, 70°F and 212°F to measure the sensor resistance at known temperatures (ice point, room temperature and sea level boiling point). For ice point and boiling point, insert the sensor in water at that temperature. Use an ohmmeter to read resistance value.
3. To check whether the control is correctly sensing temperature, use a resistance decade box. Connect the decade box temporarily in place of a sensor, and read the corresponding temperature on the control display. The temperature should be close to the value corresponding to the input resistance.

Figure 79 In-line fuses

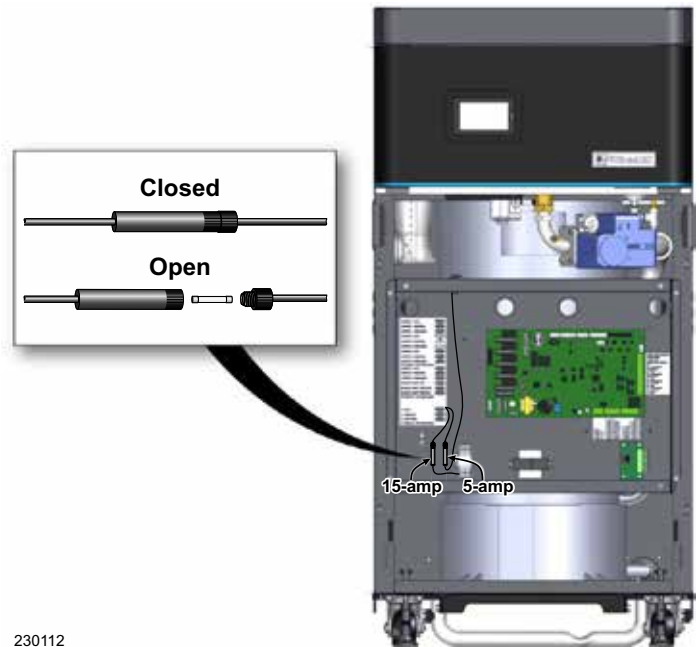

230112

Table 19 Sensor resistance values

Temp (°F)	Sensor ohms	
	Min	Max
32	34265	37871
40	27834	30764
50	21630	23907
60	16944	18727
70	13372	14780
80	10629	11747
90	8504	9399
100	6847	7568
110	5545	6129
120	4517	4992
130	3698	4088
140	3043	3364
150	2517	2782
160	2091	2311
170	1744	1928
180	1461	1615
190	1229	1359
200	1038	1147

Errors and Lockouts

Control Fault Indications

⚠WARNING

Make sure to determine the causes of outages. Do not leave the boiler operating without a complete diagnosis. Failure to comply can result in severe personal injury, death, or substantial property damage.

1. The control provides diagnostic information for both automatic and manual reset conditions. See [Figure 64, page 89](#) for information available on the control display and navigation instructions for all menus.
2. The screen behavior during a fault condition is shown in [Figure 80, page 123](#). The display illustration and text shows how to reset faults from the Home screen.
3. Conditions that will cause the control to display a constant red screen are shown in [Table 20, page 123](#). The boiler will automatically restart if the condition self-corrects, or the technician uses the Manual Reset screens to reset.

Fault History Log

The Control is able to record information about the boiler's condition at the time of the six previous faults or errors. This information is available to view in the Contractor Menus. See [Table 20, page 123](#) for the information the control will display.

1. To read the history of the last six lockouts:
 - a. Press the <DIAGNOSTICS> button.
 - b. Select <FAULT HISTORY> and press the right arrow key.
 - c. Select <LOCKOUT HISTORY #> and press the right arrow key.
 - d. Review the fault information displayed on the screen.
2. To clear all lockout history, hold the <RESET> button on the Fault History screen until cleared.

Resetting the Control

The control settings can be reset by either resetting the Wizard and inputting new information, or resetting all control settings to factory default settings.

IMPORTANT

Once a reset is chosen, previous settings cannot be recovered. Ensure this action is truly desired before continuing.

Reset Wizard:

The user must hold the <RESET WIZARD> button for a specified length of time. Completing this reset erases user specific parameter settings and takes the user back through the Wizard.

Reset to factory default:

The user must hold the <RESET FACTORY DEFAULTS> button for a specified length of time. Upon completion, this will reset the control settings back to factory installed settings.

Reset to Factory Default can be found in the Boiler Settings menu. See [Figure 66, page 91](#).

Figure 80 Control display when in lockout

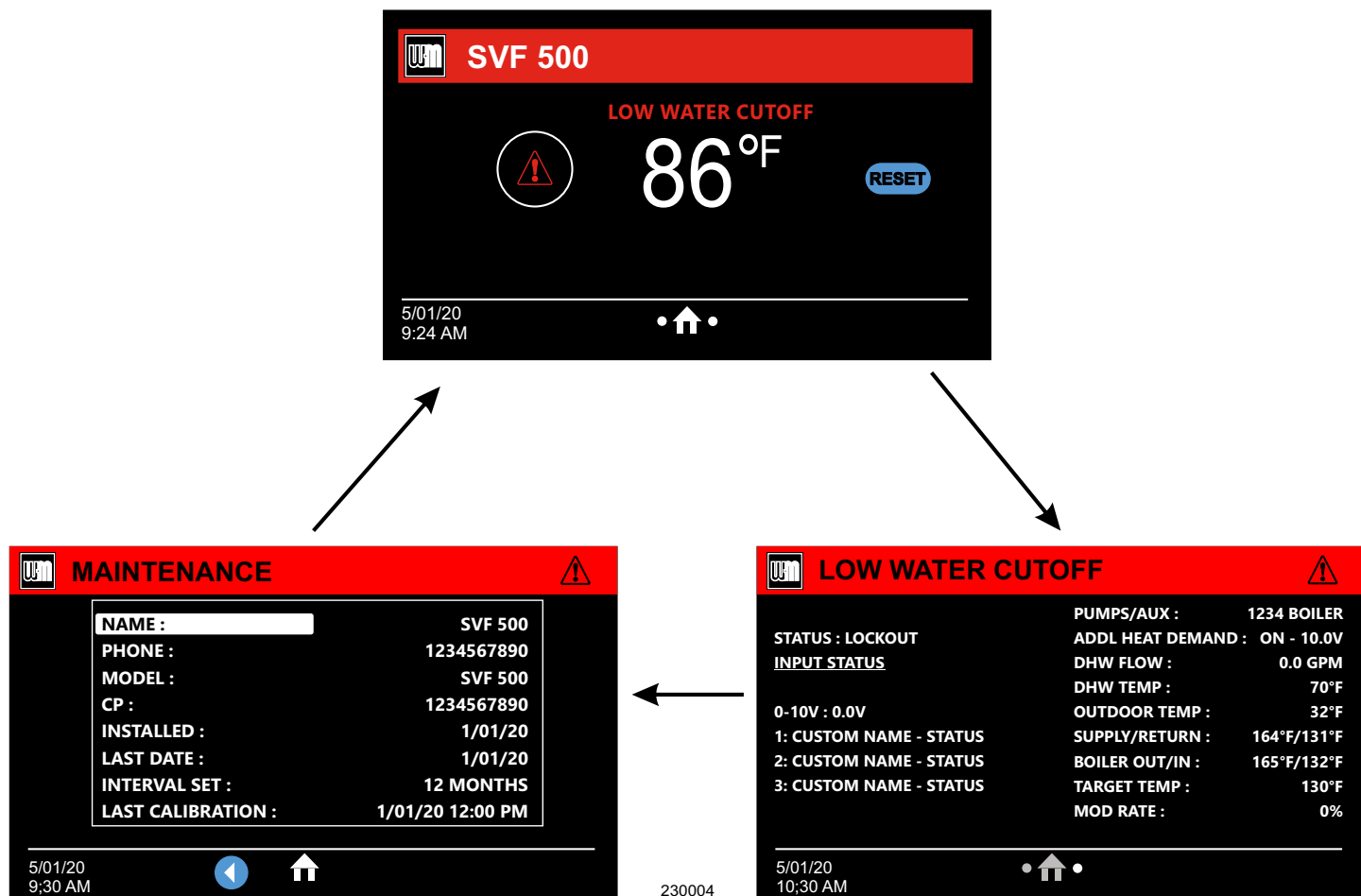

Table 20 Control fault history

Information	Description	Action
Ignition Retries	Displays cumulative ignition attempts. It is recommended that this be reset during yearly maintenance.	Press the <RESET> button to reset the count, or select this parameter and press <ENTER> to reset.
Manual Reset Count	Records number of lockouts that required a manual reset since this count was last cleared.	Press the <RESET> button to reset this count.
Auto Reset Count	Records number of lockouts that have automatically reset since this count was last cleared.	Press the <RESET> button to reset this count.
Lockout History 1- 6	Details of present or last recorded lockout, up to six previous lockouts.	Select and press the right arrow key for more details.

Errors and Lockouts, continued

Fault and Action Items

Table 21 Control fault information and troubleshooting (continued on the following pages)

Fault	Condition	Troubleshooting	Action
Nothing is shown on the display screen, and the boiler will not respond to a call for heat.	Control is not receiving 24V power.	Check wiring for short circuit or incorrect wiring.	Correct wiring per wiring diagram including connection of transformer to the control.
		Check 3-amp low voltage fuse on control shown on page 120 .	Replace fuse with proper part found in the Parts section, starting on page 131 . If fuse blows again, recheck wiring per diagrams.
		Check transformer connection to the control per wiring diagram. Check for 24V output of transformer.	Replace transformer if it is receiving 120 Vac, but not outputting 24 Vac.
Nothing is shown on the display screen, and no other boiler components are operating.	Control is not receiving 120V power.	Check service switch and/or circuit breaker to boiler is turned on.	Turn on service switch to power boiler.
		Is there 120 Vac at the service switch?	Troubleshoot and correct the power supply to the service switch.
		Check for 120 Vac at the line voltage terminal block located at J1 on the circuit board.	Correct wiring to circuit board using the wiring diagrams in this manual.
		Inspect 4-amp fuse as shown on page 120 . Replace if necessary.	Replace the fuse with proper part found in the Parts section, starting on page 131 . If fuse blows again, recheck wiring per diagrams.
Nothing is shown on the display screen, but the boiler is operating.	Occurs if the communication is lost from the control to the display.	Check for loose connections and proper pin alignment and engagement on the control's plug J14, and the back of the display circuit board.	Check for continuity on the wire harness from the display to the communications board to the circuit board.
		Cycle power off and on, and check for operation.	Replace with new display module. See the Parts section starting on page 131 for the proper part.
Boiler In Sensor Open Boiler In Sensor Short Boiler Out 1 Sensor Open Boiler Out 1 Sensor Short Boiler Out 2 Sensor Open Boiler Out 2 Sensor Short Flue 1 Sensor Open Flue 1 Sensor Short Flue 2 Sensor Open Flue 2 Sensor Short Temperature Sensor	Specified sensor is sensed as open or short.	Clears automatically when sensor is no longer open or short.	<ul style="list-style-type: none"> • Check for loose or damaged wires on the designated sensor and at the control board. • Replace appropriate sensor. • If issues persist, replace the control.
Boiler Output Sensor Flue Sensor	Occurs if dual temperature sensors values have spread by more than 10°F.	Automatically resets when sensors are within 10°F.	Follow procedure for above for SHORT and OPEN sensor conditions to properly diagnose sensors. If measured resistance values of sensors convert to temperatures separated by more than 10°F, replace the sensors.

Fault	Condition	Troubleshooting	Action
Outdoor Sensor Error	Outdoor temperature sensor is short or open.	Will automatically reset if the condition clears. Warning only: Max Target Temp is targeted until Outdoor Temp is restored, if used for target adjustment.	<ul style="list-style-type: none"> Determine which sensors are suspect and measure their resistance value and compare it to the values shown in Table 19, page 121. If the resistance values are incorrect, replace the temperature sensor. Refer to the Parts section, starting on page 131, for the proper part number. Check wire harness for loose connections and pin engagement at sensor connection, chassis mount connection through control housing, and the control. Unplug connection at sensor and at control and check continuity between ends. If problem persists after checking Items above, replace control. Refer to the Parts section, starting on page 131, for kit number.
Return Sensor	Occurs when Return Sensors are chosen as the Target Modulation sensors, and the Boiler Out sensor is either open or short.	Clears warning when valid sensors are detected.	<ul style="list-style-type: none"> Check all the temperature readings of the boiler on the Diagnostics -> Temperatures menu to determine if any sensors are currently displayed as SHORT or OPEN. Compare this to the boiler temperatures recorded in the Diagnostics -> Errors -> Lockout History # -> Temperatures during the last several lockout conditions. Determine which sensors are suspect and measure their resistance values. Compare to the values shown in Table 19, page 121. If the resistance values are incorrect, replace the temperature sensor. Refer to the Parts section starting on page 131 for the proper part number.
Supply Sensor	Occurs when Supply Sensors are chosen as the Target Modulation sensors, and the Boiler In sensor is either open or short.		<ul style="list-style-type: none"> Check wire harness for loose connections and pin engagement at sensor connection, chassis mount connection through control housing, and the control. Unplug connection at sensor and at control and check continuity between ends. If problem persists after checking Items above, replace control. Refer to the Parts section, starting on page 131, for kit number.
AIR PRESSURE Switch Open	Occurs when the High Flue Pressure switch is open.	Reset using Manual Reset screen on display.	<p>Check boiler size selected in control against boiler rating label. Correct if necessary to select the proper boiler size.</p> <p>Check the J22 connection as seen in Figure 58, page 69 and Figure 59, page 70. Check the High Flue Pressure switch per instructions on page 114.</p>
Blower Fault 1	Blower does not reach zero RPM within four minutes when mode is Standby or Prepump.	Clears automatically after one hour.	Check for loose or disconnected low voltage wires to blower motor. Inspect low voltage blower motor harness.
Blower Fault 2	Blower unable to reach required pre-purge speed or ignition speed. Blower failed to complete calibration within four minutes.	Clears automatically after one hour.	<ul style="list-style-type: none"> Check for loose or damaged wires on high voltage and low voltage blower motor harnesses. Check the in-line blower fuse connected to the 120 Vac power of the blower motor. Replace fuse if necessary. Re-calibrate blower motor in Boiler Settings menu.
Blower Fault 3	Blower is outside of minimum or maximum speed for 10 seconds.	One hour automatic reset.	<ul style="list-style-type: none"> Check for loose or damaged wires on high voltage and low voltage blower motor harnesses. Re-calibrate blower motor in Boiler Settings menu.
Blower Fault 4	Blower drops to zero RPM while burner is firing.	Automatic reset if post-purge is successful. If unsuccessful, automatic reset after 35 minutes.	<p>Check for loose or damaged wires on high voltage and low voltage blower motor harnesses.</p> <p>Check for voltage quality on incoming 120vAC and 24vAC power to the boiler, as well as 24vDC on Pin 1 of the blower motor.</p>
Boiler In > Out	Occurs when the Boiler In temp is greater than either Boiler Out temps + 10F for 30 seconds, after the burner is lit for 60 seconds, and the priority has not changed in the last 60 seconds.	Automatically resets when condition no longer exists.	<ul style="list-style-type: none"> Verify proper flow direction of the boiler circulator. Check for temperature inrush/cooling from priority switching.

Errors and Lockouts, continued

Fault and Action Items, continued

Fault	Condition	Troubleshooting	Action
Clock Fault	When the real time clock chip cannot be read.	When the real time clock chip is working correctly and has had a time written to it.	<ul style="list-style-type: none"> • Enter an updated time/date. • If problems persist, replace display.
Closure Switch fault	Proof of Closure connections on J18, Pins 2 and 3 are open.	Soft lockout for 4 minutes then unlocks and checks for up to 4 minutes. If still open, soft lockout for 4 minutes. Repeats once more then a manual lockout.	<ul style="list-style-type: none"> • Flow switch attached - Check correct pump is on, check wiring to flow switch and check switch is closing. • CAD - Check voltage to damper. Check damper is opening. • None - Check jumper on correct pins and secure connection.
Communication errors	Occurs if display or main control communications is out for 30 seconds.	Automatically resets when communication is re-established.	Check for a loose connection at the Molex plug on the control and connection on the back of the display. Improper connections may display the incorrect model numbers.
Configuration fault	Configuration data in the control safety micro does not match data in the control's application micro.	Correct the invalid configuration information.	<ul style="list-style-type: none"> • Reconfirm all settings within the Control Settings screen. Cycle power to the unit. • Perform a factory reset by going to Diagnostics -> Control Settings -> Factory Default Reset, and follow the on-screen instructions.
Control fault	Occurs when micro-controllers on main board have a RAM or ROM error.	Check for hardware damages.	<ul style="list-style-type: none"> • RAM or ROM errors can be reset with the manual reset option. • If problems persist, replace main board.
FALSE FLAME	Occurs if flame is detected when there should be no flame.	Reset using manual reset screen on display.	Burner may be operating too hot due to incorrect combustion. Inspect flame and conduct combustion test. Force boiler into high fire. Check flue gases with combustion analyzer. Correct using the maintenance and startup procedure in this manual.
			Verify FLAME SIGNAL value quickly goes to zero on the Diagnostics -> Inputs screen when the gas valve closes.
			Check for flame at burner via flame current with burner off. Turn boiler off and watch flame through observation port. If flame continues after shutdown, replace the gas valve.
Flame Circuit Fault	When the digital flame input does not sense that the circuit discharged appropriately.	Unit receives manual reset.	<ul style="list-style-type: none"> • Power cycle the boiler. • If problems persist, replace the control.

Fault	Condition	Troubleshooting	Action
FLAME LOSS FAULT	Flame value dropped below the allowable Proof of Flame threshold while running.	Automatically resets after one hour or can be reset by performing manual reset on boiler.	<ul style="list-style-type: none"> • Check condensate trap for blockage allowing condensate to accumulate inside heat exchanger. • Check ignition cable connection. <hr/> <ul style="list-style-type: none"> • Fouled, worn, bent, or faulty igniter. • Fouled ignition electrode can be cleaned for additional use with steel wool. Worn or badly fouled ignition electrode should be replaced with the proper repair part. • Igniter rods should be parallel with a 3.5 mm (0.138") spark gap. <p>⚠WARNING</p> <p><i>Thin white deposits on the igniter are typical, but brown or black deposits could be the result of flue gas recirculation. Thoroughly inspect the venting system and termination for the possibility of leakage or flue gas feedback into the air line. Failure to fix these issues can result in severe personal injury, death, or substantial property damage.</i></p> <hr/> <p>Dirty burner or heat exchanger will cause high back pressure and poor ignition. Follow instructions starting on page 110 to clean the burner and heat exchanger. Visual inspection of flue ways may not be sufficient to diagnose the condition.</p> <hr/> <p>Check combustion settings on high and low fire. Adjust per setup instructions if necessary. Check flame signal during combustion testing; see page 115.</p> <hr/> <p>Check incoming gas pressure with boiler off and at high fire. Adjust within limits on rating label.</p> <hr/> <p>Verify correct boiler model is selected in control and high altitude is selected for installations 5,500 above sea level.</p> <hr/> <p>Check that ignition cable resistance measures 1000 Ohms (+/- 50 Ohms).</p> <hr/> <p>Check for flue pipe and intake pipe restrictions or blockage.</p> <hr/> <p>Check burner fasteners and gaskets.</p> <hr/> <p>Check venturi gaskets and proper venturi. Propane models use different venturis.</p>
FLUE TEMP TOO HIGH	Occurs if flue temperature sensor exceeds 210°F (Warning) or 220°F (Lockout).	<ul style="list-style-type: none"> • Automatic reset occurs if temperature drops below 210°F for 2½ minutes. • Manual reset is required if the temperature rises above 220° F. Reset using manual reset screen on display. 	<ul style="list-style-type: none"> • Follow procedure above for SHORT and OPEN sensor conditions to properly diagnose sensor. In addition inspect heat exchanger combustion chamber and flue ways for abnormal wear or buildup. • Inspect vent system for abnormal wear or damage. • Contact WM Technologies Technical Support for assistance as needed.
GAS RELAY FAULT 1-4	The control has detected a problem with the control board's gas valve output circuit.	Control will do automatic retry; lockout if retry is unsuccessful. Retry one hour after lockout — restart if condition cleared, but lockout requiring manual reset if condition still present.	<ul style="list-style-type: none"> • Requires manual reset if control is in lockout. • If lockout reoccurs replace control.
Hardware A2D Fault	The analog reading of the internal voltage reference on U1 reads out of range two times in a row.	Clears when the analog internal voltage reference is within range.	<ul style="list-style-type: none"> • Power cycle the boiler. • If problems persist, replace the control.

Errors and Lockouts, continued

Fault and Action Items, continued

Fault	Condition	Troubleshooting	Action
HIGH TEMP LIMIT	Boiler temperature sensor reached High Temp Limit setting.	Reset using manual reset screen on display.	Verify that high limit setting is at least 10° F above the maximum target temperature <u>plus</u> the off differential.
			<ul style="list-style-type: none"> Verify all isolation valves are open and circulators are programmed into the control properly. The boiler circulator output and System Pump/Aux output can be configured to turn on or off with each priority. Refer to the Advanced Manual (part number 550-100-207) to configure these properly for the system.
			Verify water pipe is installed correctly per instructions in this manual.
			Verify proper circulator sizing for boiler size and system requirements.
			See message displayed for the temperature sensor (boiler in, boiler out, flue, and temperature sensors) and follow procedure for loose connections.
IGNITION 1 FAULT	Boiler went through two ignition attempts and either never detected flame, or flame sense value never reached proof of flame threshold of 0.8 within 2 seconds.	Reset using manual reset screen on display.	<ul style="list-style-type: none"> Check condensate trap for blockage allowing condensate to accumulate inside heat exchanger. Check ignition cable connection.
			<ul style="list-style-type: none"> Fouled, worn, bent, or faulty igniter. Fouled ignition electrode can be cleaned for additional use with steel wool. Worn or badly fouled ignition electrode should be replaced with the proper repair part. Igniter rods should be parallel with a 3.5 mm (0.138") spark gap. <p>⚠WARNING</p> <p><i>Thin white deposits on the igniter are typical, but brown or black deposits could be the result of flue gas recirculation. Thoroughly inspect the venting system and termination for the possibility of leakage or flue gas feedback into the air line. Failure to fix these issues can result in severe personal injury, death, or substantial property damage.</i></p> <p>Dirty burner or heat exchanger will cause high back pressure and poor ignition. Follow instructions starting on page 110 to clean the burner and heat exchanger. Visual inspection of flue ways may not be sufficient to diagnose condition.</p> <p>Check combustion settings on high and low fire. Adjust per setup instructions if necessary. Check flame signal during combustion testing; see page 115.</p> <p>Check incoming gas pressure with boiler off and at high fire. Adjust within limits on rating label.</p> <p>Verify correct boiler model is selected in control and high altitude is selected for installations 5,500 above sea level.</p> <p>Check that ignition cable resistance measures 1000 Ohms (+/- 50 Ohms).</p> <p>Check for flue pipe and intake pipe restrictions or blockage.</p> <p>Check burner fasteners and gaskets.</p> <p>Check venturi gaskets and proper venturi. Propane models use different venturis.</p>
IGNITION 2 FAULT	Boiler went through two ignition attempts and did not meet running flame threshold for boiler model within 10 seconds		

Fault	Condition	Troubleshooting	Action
Internal Clock Fault	Occurs when the internal clock of the control is out of sync.	Clears when the control sees a valid clock count within the control.	<ul style="list-style-type: none"> • Cycle power of the boiler. • Check the wiring of the display. • If problem persists, replace display.
LIMIT OPEN	Occurs if manual or automatic reset limit opens.	<ul style="list-style-type: none"> • Automatic external limit will reset 2½ minutes after external limit device closes. • Manual limit fault must be reset by choosing Manual Reset on the display. 	<p>Is there an external safety device connected? If yes, troubleshoot the external limit to determine and correct the cause that opened the limit. Also check for loose wiring connections.</p> <ul style="list-style-type: none"> • Remove the Control cover and inspect the connector. • Ensure a jumper is installed across the MAN LIMIT terminals if not using a manual reset external limit. • Ensure a jumper is installed across the AUTO LIMIT terminals if not using a automatic reset external limit.
LOW FLAME SHUTDOWN	Flame quality dropped below allowable Running Flame Threshold, but it did not go out.	Automatically clears when pre-purge is reached.	<ul style="list-style-type: none"> • Fouled, worn, bent, or faulty igniter. • Fouled ignition electrode can be cleaned for additional use with steel wool. Worn or badly fouled ignition electrode should be replaced with the proper repair part. • Igniter rods should be parallel with a 3.5 mm (0.138") spark gap. <p>⚠WARNING</p> <p><i>Thin white deposits on the igniter are typical, but brown or black deposits could be the result of flue gas recirculation. Thoroughly inspect the venting system and termination for the possibility of leakage or flue gas feedback into the air line. Failure to fix these issues can result in severe personal injury, death, or substantial property damage.</i></p> <p>Dirty burner or heat exchanger will cause high back pressure and poor ignition. Follow instructions starting on page 110 to clean the burner and heat exchanger. Visual inspection of flue ways may not be sufficient to diagnose condition.</p> <p>Check combustion settings on high and low fire and adjust per setup instructions if necessary. Check flame signal during combustion testing; see page 115.</p> <p>Check incoming gas pressure with boiler off and at high fire. Adjust within limits on rating label.</p> <p>Verify correct boiler model is selected in control and high altitude is selected for installations 5,500 above sea level.</p> <p>Check that ignition cable resistance measures 1000 Ohms (+/- 50 Ohms).</p> <p>Check for flue pipe and intake pipe restrictions or blockage.</p> <p>Check burner fasteners and gaskets.</p> <p>Check venturi gaskets and proper venturi. Propane models use different venturis.</p>
LOW WTR CONDITION	Occurs if the integrated LWCO sees no water.	Manual reset of control if contacts are open.	<ul style="list-style-type: none"> • Check for low water condition in system. Repair system as necessary. Refer to the water piping section of this manual, starting on page 19. • Check if LWCO test button is stuck. If so, replace control. • If low water condition does not exist, check Diagnostics -> Inputs screen to view status of LWCO. If the LWCO is shown as OPEN, check wiring between LWCO and control. If wiring is fine, remove LWCO and clean the probe. If the problem still exists, replace the LWCO.
LOW WTR CUTOFF OPEN	Occurs if internal LWCO contacts open.	Manual reset of control if contacts are open.	<ul style="list-style-type: none"> • Check for low water condition in system. Repair system as necessary. Refer to the water piping section of this manual, starting on page 19. • If low water condition does not exist, check Diagnostics -> Inputs screen to view status of LWCO. If the LWCO is shown as OPEN, check wiring between LWCO and control. If wiring is fine, remove LWCO and clean the probe. If the problem still exists, replace the LWCO.
LOW WTR CUTOFF WARNING	Occurs if the LWCO needs to be cleaned.	Automatically clears when the condition no longer exists.	Follow maintenance instructions for removal and cleaning of Boiler In > Out LWCO probe.



Errors and Lockouts, continued

Fault and Action Items, continued

Fault	Condition	Troubleshooting	Action
Software Incompatible	Main control and display software are not compatible.	Unit is updated to matching software.	Check software versions for main control and display. Replace the hardware that is the incorrect software version.
Supply 60F > Return	<ul style="list-style-type: none"> Occurs if either Boiler Out temperatures are greater than Boiler In temperature by more than 60F, or the burner has been on for less than 2 minutes. If this condition occurs when the burner has been on for more than 2 minutes, the burner stops firing but no message or lockout occurs. 	<p>The first time a lockout occurs, the time to clear is 2 minutes 30 seconds. The second time, the lockout is 3 minutes 30 seconds. The third time, its 4 minutes 30 seconds, the fourth time its 5 minutes 30 seconds. The fifth time its 6 minutes 30 seconds.</p> <p>The system will retry, indefinitely, every 6 minutes 30 seconds as long as the temperatures return to < 60 degrees.</p> <p>If the burner fires for at least 2 minutes without the temperature difference exceeding 60 degrees, the time condition for the > 60 degree soft lockout is reset back to the minimum value of 2 minutes 30 seconds.</p>	<ul style="list-style-type: none"> Ensure proper water flow is present through boiler. Ensure circulators are sized correctly per the system installation and are installed correctly. Check wiring to circulators.
System Return > Supply	Occurs when the System Return temp is greater than the System Supply temp + 10F, after the burner is lit for 10 minutes, and the priority has not changed in the last 10 minutes.	Automatically resets when condition no longer exists.	<ul style="list-style-type: none"> Verify proper placement of system sensors. System sensors should be on system piping not on the boiler loop. Verify sensors are wired to correct terminal locations. System sensors may need to be located further away from the boiler loop connection to the system, if proximity to the boiler loop is causing sensors to be heated inaccurately.
Target Reduced – Boiler	<p>Boiler Outlet sensor detected above Max Boiler Temp minus Boiler Out On Diff.</p> <p>This fault can only occur if using System Supply or DHW Out as a modulation sensor*</p>	Clears warning when Boiler Outlet sensor is detected below Max Boiler Temp minus Boiler Out On Diff.	No corrective action required. Boiler is operating normally.
Target Reduced – Flow	Boiler Outlet sensor detected > Boiler Inlet sensor + 50°F. Modifies Target temperature to prevent over-stressing the heat exchanger.	Clears warning and target modification when Boiler Outlet sensor is detected ≤ Boiler Inlet sensor + 50°F.	<ul style="list-style-type: none"> Check water flow through the boiler heat exchanger. Check circulators for malfunction or wiring issues.
Target Reduced – Flue	Flue temperature detected between 200°F and 210°F. Modifies target temperature to prevent overheating flue.	Clears warning when Flue temperatures have been below 200°F and the target has returned to its original setpoint, then one hour of burner run time has elapsed without the Flue temperature exceeding 200°F.	<ul style="list-style-type: none"> Check the flue pipe for any blockages. Check the CO₂ readings using an analyzer and adjust gas valve accordingly to match nominal CO₂ readings within the boiler manual.
TEMP RISE TOO QUICKLY	Occurs if supply water temperature in heat exchanger rises faster than 10°F per second for two seconds during the first two minutes the burner is on.	<ul style="list-style-type: none"> Automatically resets after one minute delay or using manual reset on display. Manual reset is necessary after 5 automatic resets have occurred during the same Priority heat demand. Reset using manual reset screen on display. 	<p>Verify water pipe is installed correctly per instructions in this manual.</p> <p>Verify proper circulator and speed for boiler size and system requirements.</p> <p>See message displayed TEMPERATURE SENSOR and follow procedure for loose connections.</p>
Unconfigured Net 1 or Net 2 Demand	Net 1 or 2 input active when its priority settings have not been configured.	Clears once configured. Boiler will not run this priority while this warning is active.	Configure Net 1 or 2 priority settings in the system settings menu.
Virtual Input Active	If Modbus is activating any virtual TT input.	No virtual inputs are active.	Check Modbus communication device for virtual TT input commands.

SECTION 7

Parts

This section includes replacement parts and ordering information.

Section Contents

Miscellaneous Parts	131
Ordering	131
The SVF Commercial Condensing Water Boiler	132
Replacement Parts	134
Dimensions	140

Miscellaneous Parts

See Table 22 for miscellaneous part numbers and descriptions for ordering purposes.

Ordering

Replacement parts must be purchased through a WM Technologies distributor. Specify the boiler model and size when ordering. Include the description and part number of the replacement part. Part numbers are found on www.weilmclain.com and the following pages.

CAUTION

Results from using modified, other manufactured parts, and parts not purchased through an authorized distributor will not be covered by warranty. These parts may damage the boiler or impair operation.

Table 22 Miscellaneous parts and kits

Description	Part Number
Condensate Neutralizer Kit	383600076
Pressure Relief Valve:	
Watts 740 3/4" x 1" 925,000 Btu/hr. 30 PSI	383600063
Watts 740 3/4" x 1" 1,352,000 Btu/hr. 50 PSI	383600064
Watts 174A 3/4" x 3/4" 1,400,000 Btu/hr. 80 PSI	383600521
Watts 174A 3/4" x 3/4" 1,695,000 Btu/hr. 100 PSI	384000149
Watts 174A 3/4" x 3/4" 2,445,000 Btu/hr. 150 PSI	384000150
Antifreeze, Sentinel X500 (5 gallons)	592900006
Corrosion Inhibitor, Sentinel X100 (5 gallons)	592900016
Corrosion Inhibitor, Sentinel X100 (50 gallons)	592900017
Corrosion Inhibitor, Sentinel X400 (1 gallons)	592900028
Corrosion Inhibitor, Sentinel X400 (5 gallons)	592900022
Inhibitor Quick-Test Kit	592900005
Bird Screens (2 required) — for 4" PVC vent and air pipes	383500110
Kit – Service Annual Maintenance Kit SVF 500/600: (electrode igniter, insulation, gaskets, fasteners)	384000422
Conversion Kit, Natural Gas to LP SVF 500/600 (venturi, venturi gasket, O-ring, LP orifice, hardware, instructions)	384000423
Kit – Service Automatic Air Valve	384000153
Minimum Water Flow Switch Kit	384000324
Isolation Valve, 2" NPT	384000368
Replacement Isolation Valve Actuator	BP00000733
Isolation Valve Position Switch	BP00000734
Circulator Taco VR15L 1-1/2" ANSI Flange	511405156
Wireless Outdoor Temperature Sensor Kit	384000325
System Water Temp Sensor (strap-on style)	383500601
IPEX PVC Concentric Vent Kit – available from IPEX:	
Kit for 4" PVC Vent and Air Pipes	196021
PVC Concentric Vent Kit – Horizontal or Vertical (includes components for concentric assembly):	
Kit for 4" PVC Vent and Air Pipes	383900075
Kit – Service 4" Vent Termination Plate	383500398
Low Water Cut-Off	511100005

The SVF Commercial Condensing Water Boiler

Legend for Figure 81, page 133

- 1. Stainless steel heat exchanger**
72.91 square ft. of surface for heat transfer. SA-240 stainless steel, grades 316Ti, 316L, UNS S34035, and UNS S44400.
- 2. Burner/heat exchanger cover plate**
- 3. Blower**
Air enters through the air inlet adapter, then enters the venturi. The blower pulls air and gas through the venturi and pushes the mixture into the burner. The advanced blower design and air inlet silencer yield very quiet operation.
- 4. Control Module (see Control Overview on page 83)**
The control module is used to configure boiler settings and monitor boiler operation. The touchscreen allows for changing the display mode, entering setting values, and resetting after lockout.
- 5. Transformer**
- 6. Ignition transformer**
- 7. ON/OFF switch**
- 8. Automatic gas valve**
The automatic gas valve incorporates two solenoid-operated valve seats. The valve senses the vacuum in the venturi (item 5) caused by flowing air. Gas flows in proportion to air flow, so the air to fuel ratio remains constant as blower speed and air flow changes.
- 9. Manual ball gas valve with pressure port**
- 10. Air vent - Automatic air vent**
- 11. Electrical entrance snap-in covers**
Knockouts are provided in the terminal box, allowing conduit entry right of the low-voltage and line-voltage field wiring terminal strips.
- 12. High gas pressure switch**
Mounted on the side of the gas valve.
- 13. Low gas pressure switch**
Connects to the port on the tee that is installed on the inlet gas pipe near the gas valve.
- 14. Air pressure switch**
Maximum flue pressure.
- 15. Premix gas burner (not shown)**
Made with high-grade stainless steel and fiber mesh construction, the burner uses pre-mixed gas and air.
- 16. Ignition electrode**
The burner flame is ignited by applying a high voltage to the ignition electrode, which is located in the combustion chamber. This causes a spark (from electrode to ground). The ignition electrode also measures flame signal after ignition.
- 17. Flame inspection windows**
Quartz glass windows provide a view of the burner surface and flame.
- 18. Water outlet pipe (system supply)**
2" MNPT fittings.
- 19. Water return pipe (system return)**
2" MNPT fittings.
- 20. Gauge port (not shown)**
The pressure and temperature gauge is shipped loose for field installation. Contractor must supply and install a tee on the water outlet pipe (system supply) for this installation.
- 21. Relief valve nipple (not shown)**
The relief valve is shipped loose for field installation. Contractor must supply and install a tee on the water outlet pipe (system supply) for this installation.
- 22. Temperature sensor port - outlet water temperature**
The outlet sensor port is located on top of the water outlet pipe (system supply), just outside the heat exchanger. The LWCO is integrated into this sensor. The LWCO test button is on the control, and manual reset is done through the main control.
- 23. Temperature sensor port - inlet water temperature**
The return sensor port is located on top of the water return pipe (system return), just outside the heat exchanger.
- 24. Flue temperature port sensor (not shown)**
- 25. Gas connection - 1-1/4" MNPT**
- 26. Vent connection**
3-in-1 adapter allows PVC/CPVC, PolyPro, or stainless steel connection. If using PP or SS brands other than M&G DuraVent, consult the manufacturer for proper adapter.
- 27. Jacket panels**
The front and side jacket panels are removable for access to the blower, gas valve, pressure switches, controls, and ASME rating plate.
- 28. Boiler top panel**
- 29. Casters (used for locating the boiler only)**
- 30. Leveling legs (extended after the boiler is in position)**
- 31. Heat exchanger drain connection**
- 32. Condensate trap**
- 33. ASME rating plate**
This plate has all the ASME Section IV required information.
- 34. Air inlet adapter**
- 35. Silencer**
The silencer significantly reduces fan noise, providing exceptionally quiet operation.
- 36. Venturi**
When air flows through the venturi, a negative pressure is created. This pressure causes gas to flow from the gas valve into the venturi, where it is mixed with the air. The gas and air mixture then continues into the blower.
- 37. The Multi Boiler / Comm Board**
Communication Board: The communication board provides boiler-to-boiler communication and Building Management System (BMS) interface
- 38. High voltage terminal strip**
120VAC field wiring connections.
- 39. Electronic display**
The electronic color touch screen display is used to configure boiler settings and monitor boiler operation. This display allows changing display mode, selecting and adjusting control settings, and resetting the control after lockout.

Figure 81 The SVF commercial condensing water boiler

Electrical Panel Components

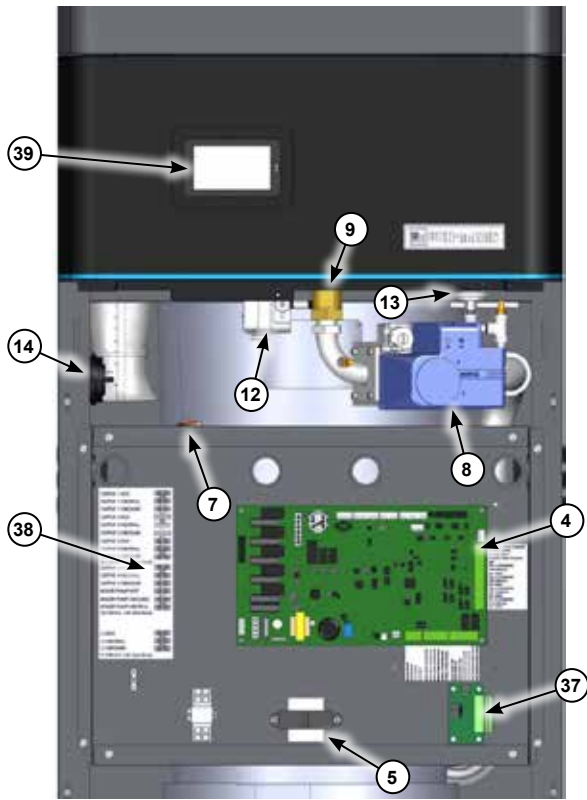

Components - Top View

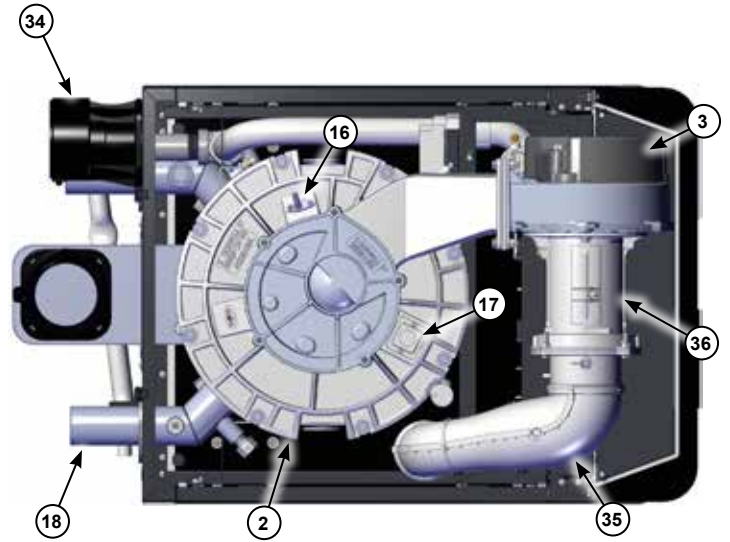

Components - Back View

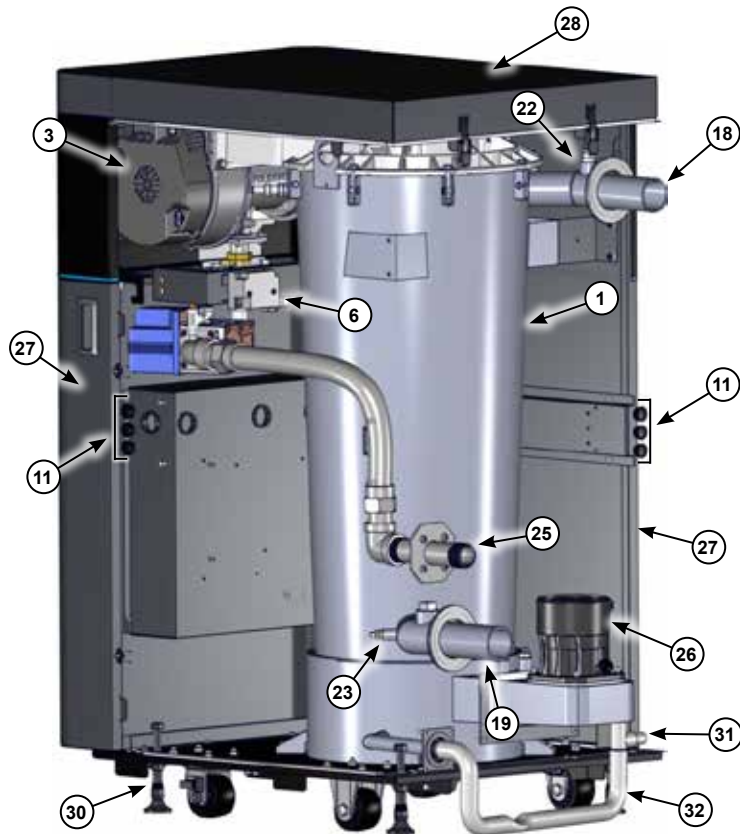

Components - Front View

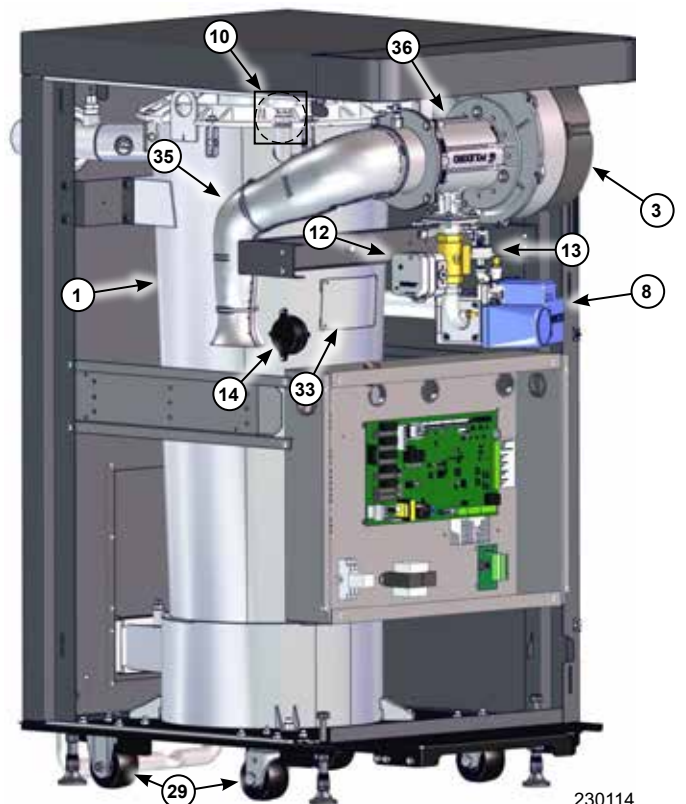

Figure 82 Jacket parts

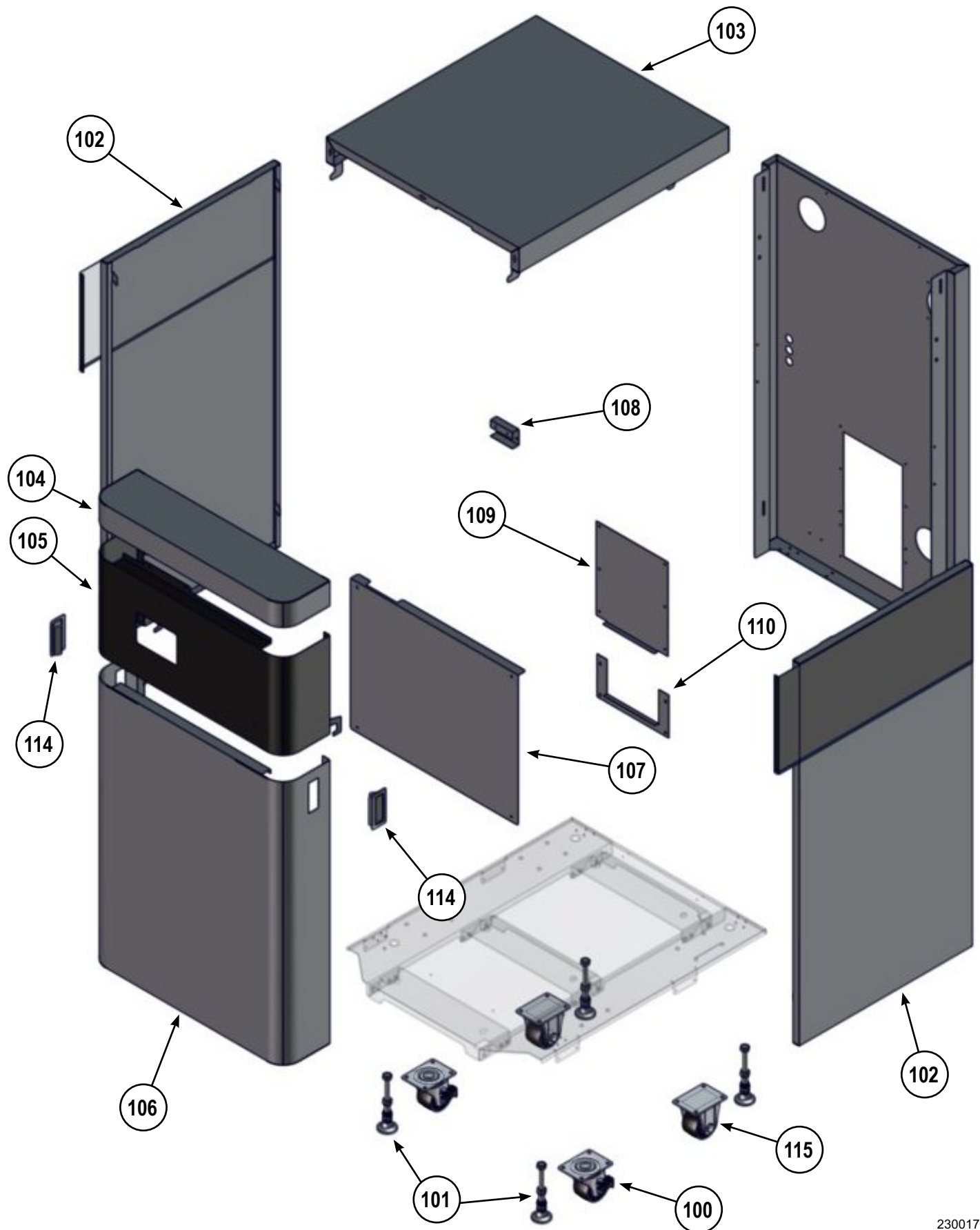
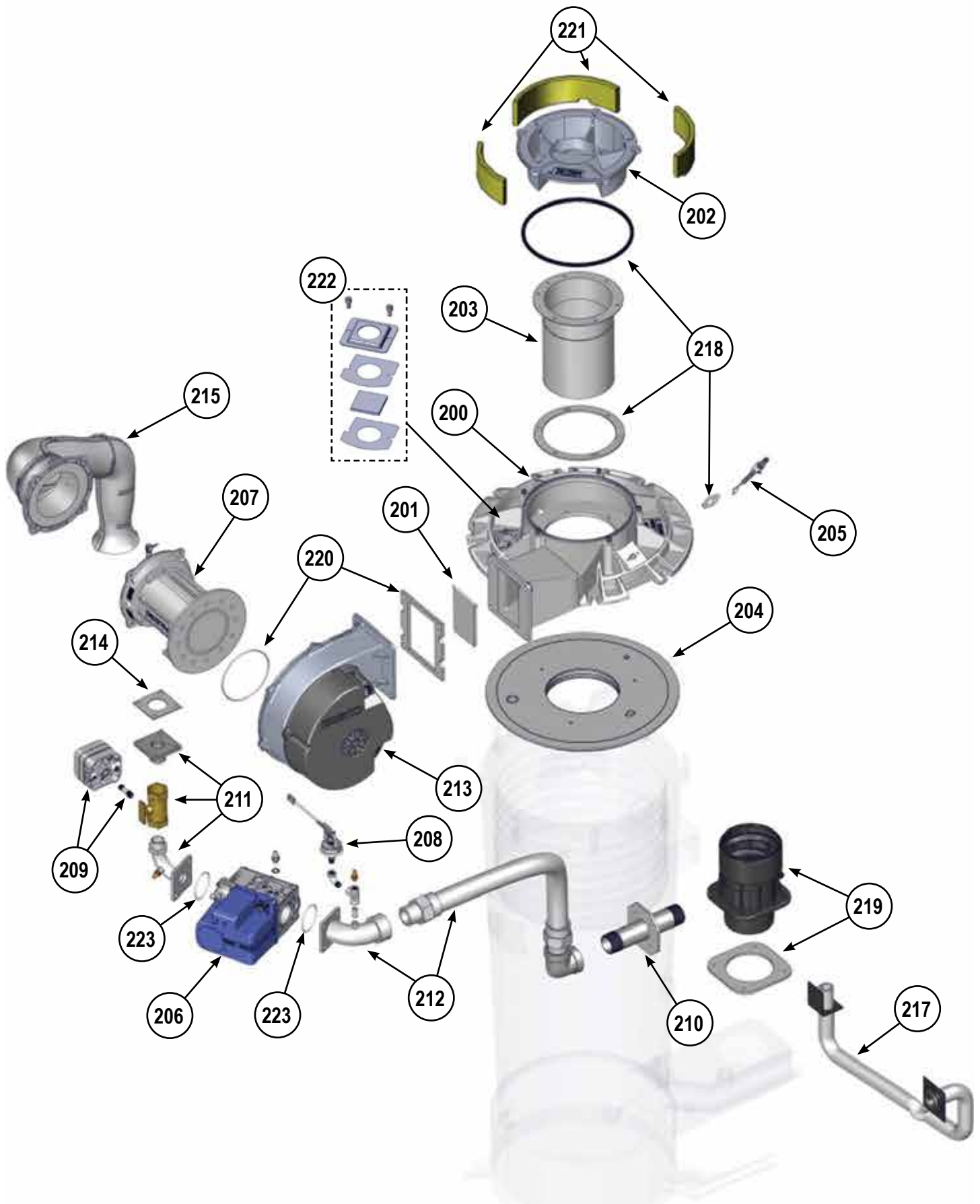

Figure 83 Combustion, condensate



7

Replacement Parts, continued

Table 25 Control parts and part numbers for [Figure 84, page 139](#)

Item	Description	Part Number
300	Kit – Service Water Temperature Sensor + LWCO	381356589
301	Kit – Service Water Return Sensor	383600071
302	Kit – Service COFI Transformer w/Flame Sense Pass Through	384000425
303	Kit – Service Module Control Main 1225-100	384000395
304	Kit – Service 120V-24V Transformer	384000427
305	Kit – Service High Flue Pressure Switch	384000372
306	Kit – Service Module Display 1209-376-R	384000396
307	Kit – Service Temperature Sensor, Outdoor (not shown)	383500125
308	Kit – Service Flue Temperature Sensor 500/600	384000100
309	Kit – Service Harness High Voltage SVF 500/600 (not shown)	384000412
310	Kit – Service Harness Low Voltage SVF 500/600 (not shown)	384000413
311	Kit – Service Harness Blower PWM SVF 500/600 (not shown)	384000414
312	Kit – Service Harness Flue Pressure Switch SVF 500/600 (not shown)	384000415
313	Kit – Service Harness COFI and Gas Valve SVF 500/600 (not shown)	384000416
314	Kit – Service Harness High/Low Gas Pressure Switches SVF 500/600 (not shown)	384000417
315	Kit – Service Harness Modbus SVF 500/600 (not shown)	384000418
316	Kit – Service Harness Display SVF 500/600 (not shown)	384000419
317	Kit – Service Fuse 5A 250 Vac 6.3 x 32mm (not shown)	384000424
318	Kit – Service Conversion ProtoNode BacNet (not shown)	384000420
319	Kit – Service Conversion ProtoNode LonWorks (not shown)	384000421
320	Kit – Service System Immersion Sensor 12k (not shown)	384000292
321	Kit – Service Fuse 5-pack 2.5A 120 Vac (not shown)	384000428
322	Kit – Service Fuse 5-pack 3A 24 Vdc (not shown)	384000429
323	Kit – Service Fuse 5-pack 4A 120 Vac (not shown)	384000430
324	Kit – Service Electrical Connectors Control (not shown)	384000431
325	Kit – Service RS485 communication board (not shown)	384000432
327	Kit – Service Multi-boiler wiring kit (RS-485 communication harness) – one kit needed per boiler (not shown)	383700272
328	Kit – Service Harness Wiring Igniter Ground SVF 500/600 (not shown)	384000434
329	Kit – Service Harness Circulator High Voltage 500/600 (not shown)	384000435
330	Kit – Service Harness Wiring HGPS SVF 500/600 (not shown)	384000436

Figure 84 Controls, sensors

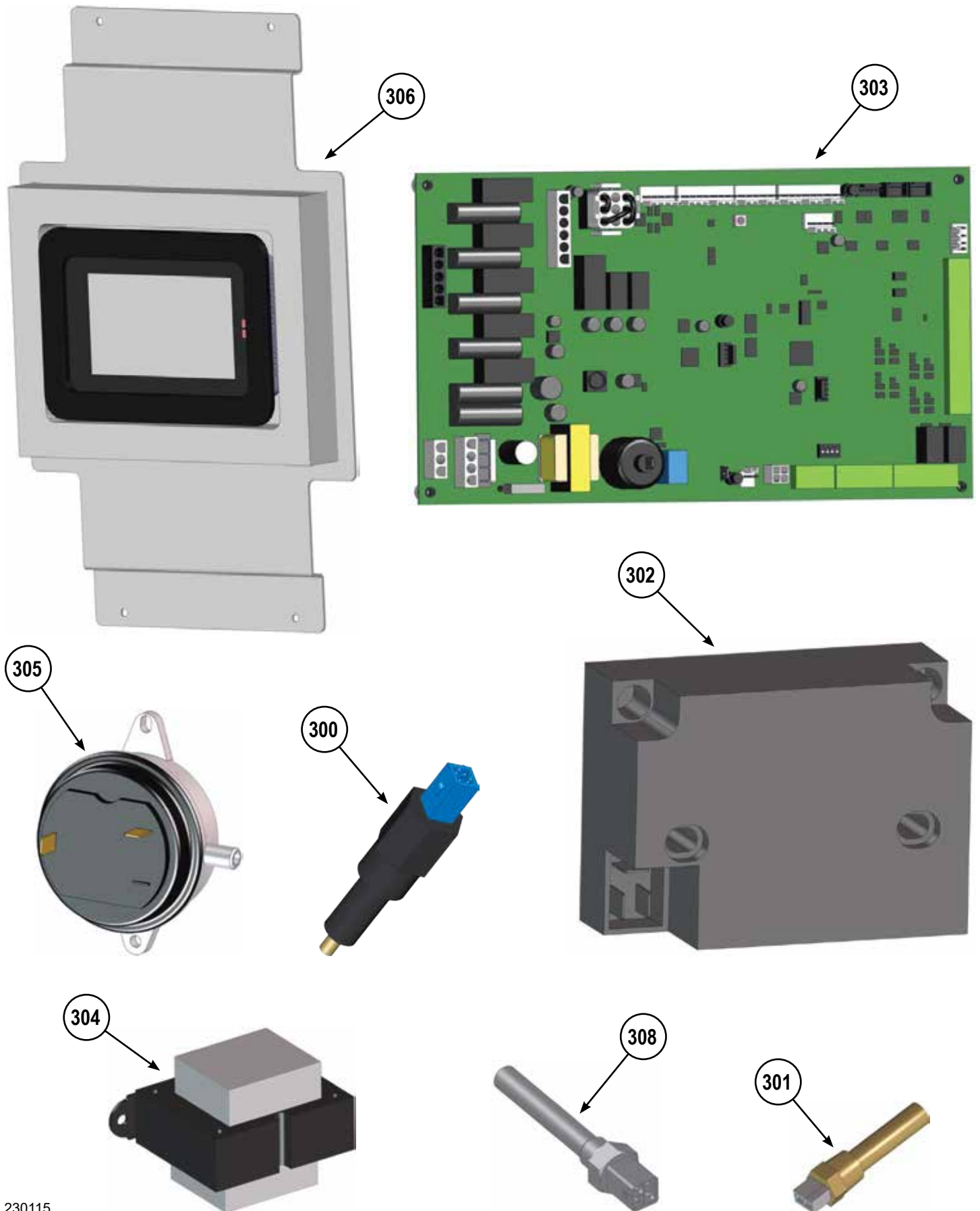

Dimensions

Figure 85 Dimensional data

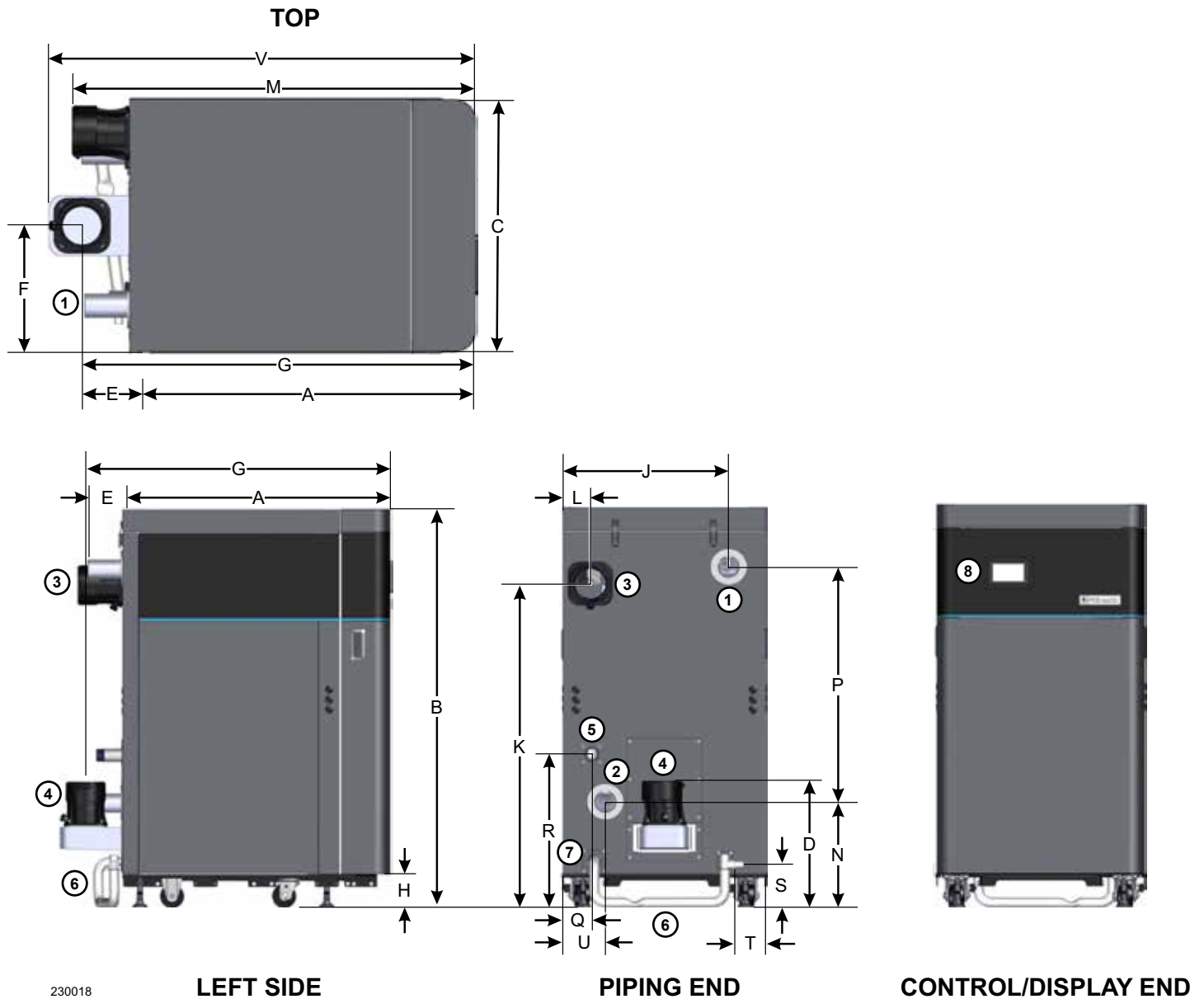

230018

LEFT SIDE

PIPING END

CONTROL/DISPLAY END

Legend – Figure 85

- 1. Boiler water out, 2" NPT
- 2. Boiler water in, 2" NPT
- 3. 3-in-1 air inlet adapter, 4"
- 4. 3-in-1 flue adapter, 4"
- 5. Gas in, 1-1/4" NPT
- 6. Condensate trap assembly
- 7. Condensate drain tube
- 8. Control

SVF 500/600 DIMENSIONS (inches) - height dimensions given are based on casters resting on the ground. Add lifted boiler measurements to height dimensions accordingly.

A	B	C	D	E	F	G	H	J	K
33-3/8	49-13/16	24-7/8	15-13/16	4-5/8	12-1/2	38	4-1/4	20-1/3	40-7/16
L	M	N	P	Q	R	S	T	U	V
3-7/16	39-1/16	13-3/16	29-5/16	2-5/8	19-1/8	5-3/8	3-13/16	5-1/4	41-5/16

SECTION 8

Service Information

Section Contents

Ratings	141
Read Configuration Settings	143
Maintenance Log	145
Installation and Service Certificate	146
Notes	146

Ratings

Table 26 Multi-boiler ratings

Boilers in System		Total CSA Input	CSA Output / DOE Heating Capacity	Boiler H.P.	Net Water Rating	Manifold Combustion Air Duct Size
		Input, MBH	Output, MBH	-	MBH	Square Inches
SVF 500	SVF 600	-	Note 1	-	Note 2	
2		1000	980	29.3	852	500
	2	1200	1176	35.1	1022	600
3		1500	1470	43.9	1278	750
	3	1800	1764	52.7	1533	900
4		2000	1960	58.5	1704	1000
	4	2400	2352	70.3	2044	1200
5		2500	2450	73.2	2130	1250
	5	3000	2940	87.8	2555	1500
6		3000	2940	87.8	2556	1500
	6	3600	3528	105.4	3066	1800
7		3500	3430	102.5	2982	1750
	7	4200	4116	122.9	3577	2100
8		4000	3920	117.1	3408	2000
	8	4800	4704	140.5	4088	2400

Notes

1. Based on standard test procedures outlined by DOE for individual boilers.
2. Net water ratings are based on piping and pickup allowance of 1.15. Consult Weil-McLain Technical Services for other allowances.



Ratings, continued

Table 27 Ratings and engineering data

DOE



AHRI Certified Ratings

Boiler Model Number	Maximum Input	Minimum Input - Natural Gas	Minimum Input - Propane Gas	Gross Output	Net Rating	Thermal Efficiency	Boiler Water Content	Vent/Air Pipe Size	Stack/Vent Flow Rate	Boiler Weight (pounds)		
	Btuh (Note 1)	Btuh (Note 1)	Btuh (Note 1)	Btuh (Note 1)	Btuh (Note 2)	% (Note 3)	Gallons	Inches (Note 4)	scfm (Note 5)	Dry Weight (no water)	Operating Weight (filled)	Shipping Weight
SVF 500	500000	50000	50000	490000	426000	98.0	12.4	4	105	468	571	611
SVF 600	600000	50000	50000	588000	511000	98.0	12.4	4	125	468	571	611

Notes

- Ratings shown are for sea level applications only. For altitudes above sea level, the SVF boiler requires no modifications; it automatically derates itself by approximately 4% per 1,000 ft. above sea level. For elevations over 2,000 ft., see the High Altitude section on page 116 for required control parameter changes. The length of the vent and air piping will affect the maximum input. See Table 28 below for derate % according to vent and air piping length.
- Net AHRI ratings are based on net installed radiation of sufficient quantity for the requirements of the building, and nothing needs to be added for normal piping and pickup. Ratings are based on a piping and pickup allowance of 1.15. An additional allowance should be made for unusual piping and pickup loads.
- Thermal efficiency is based on AHRI testing procedure AHRI 1500.
- SVF boilers can be direct vent or direct exhaust vented, either through a side wall or through the roof, as instructed in this manual and compliant with all local codes. SVF boilers require special venting, consistent with Category IV boilers. For Category II boiler systems, see pages 32 to 35. Use only the vent materials and methods identified in this manual.
- The values are for the stack flow rate at the maximum firing rate for the given boiler. The values can vary, depending on the location of the installation and the operating conditions.

Table 28 Derate due to vent and air piping length

Boiler Model	Determine vent/air piping equivalent length (ft.) - Use the length for L in the equations.	
	Derate % for Direct Exhaust	Derate % for Direct Vent
SVF 500/600	% Derate = $L \times .077$	% Derate = $L \times .074$
	Example: If $L = 75$ ft., Derate % = $75 \times .077 = 5.775$	Example: If $L = 75$ ft., Derate % = $75 \times .074 = 5.550$

Read Configuration Settings

Bluetooth Connection

To access configuration settings, connect to Bluetooth.

1. Swipe right on the display to navigate to the Menu screen.
2. Press the <BLUETOOTH> button. See Figure 86.
3. Toggle the Bluetooth ON by pressing the blue toggle button. See Figure 87. Bluetooth will remain on for 30 minutes of inactivity.
4. Turn on the Bluetooth of your smartphone device.

Saving the Boiler Configuration

Connecting to the WM ProTools™ app allows the boiler configuration to be loaded, saved, and viewed. To download the app, point the smartphone camera at the QR code in Figure 88, then click the link on the screen.

1. Open the WM ProTools app. See [Figure 89, page 144](#)
2. Press the <Connect> button.
3. Press <Connect to Boiler>.
4. Press the WM boiler to connect to on the screen.

IMPORTANT

If no boilers appear in the list, toggle the Bluetooth radio of the boiler off then on again. Wait for the Bluetooth screen of the display to connect via the app before navigating away from this screen.

5. Swipe down to view the connectivity options. Choose the <READ/WRITE Configuration> button.
6. Press <READ Configuration>. It takes several seconds to gather all configuration information of the boiler.
7. Review the information, then press <Save Configuration> at the bottom of the screen.
8. Choose a descriptive name for the saved configuration, then press the <Save> button.

IMPORTANT

Files are saved locally on the phone. If the app is uninstalled, all files are lost. Save the information for your records.

9. To view any saved files, at step 6 above press <WRITE Configuration> instead.

Figure 86 Menu screen

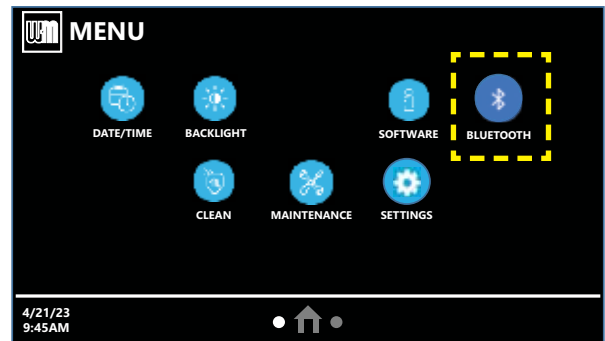

Figure 87 Toggle the Bluetooth connection

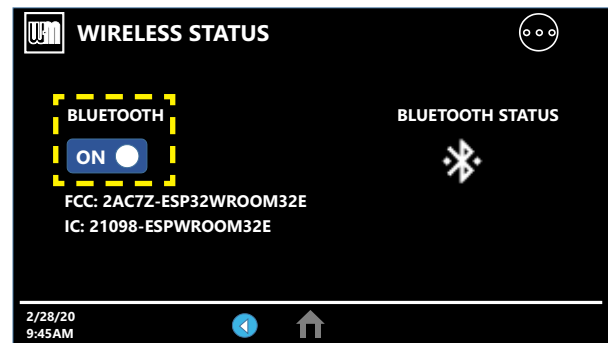

Figure 88 WM ProTools app download



- a. Choosing WRITE Configuration will bring up a list of configurations saved on your device.
- b. Pressing any of the bubbles will open that file.

IMPORTANT

DO NOT WRITE a file unless certain the configuration is correct for your application.

10. Write Configuration is possible with the app. The Model number and Master/Shadow/Single settings must match the boiler for a successful Write Configuration to occur.

Figure 89 WM ProTools app navigation

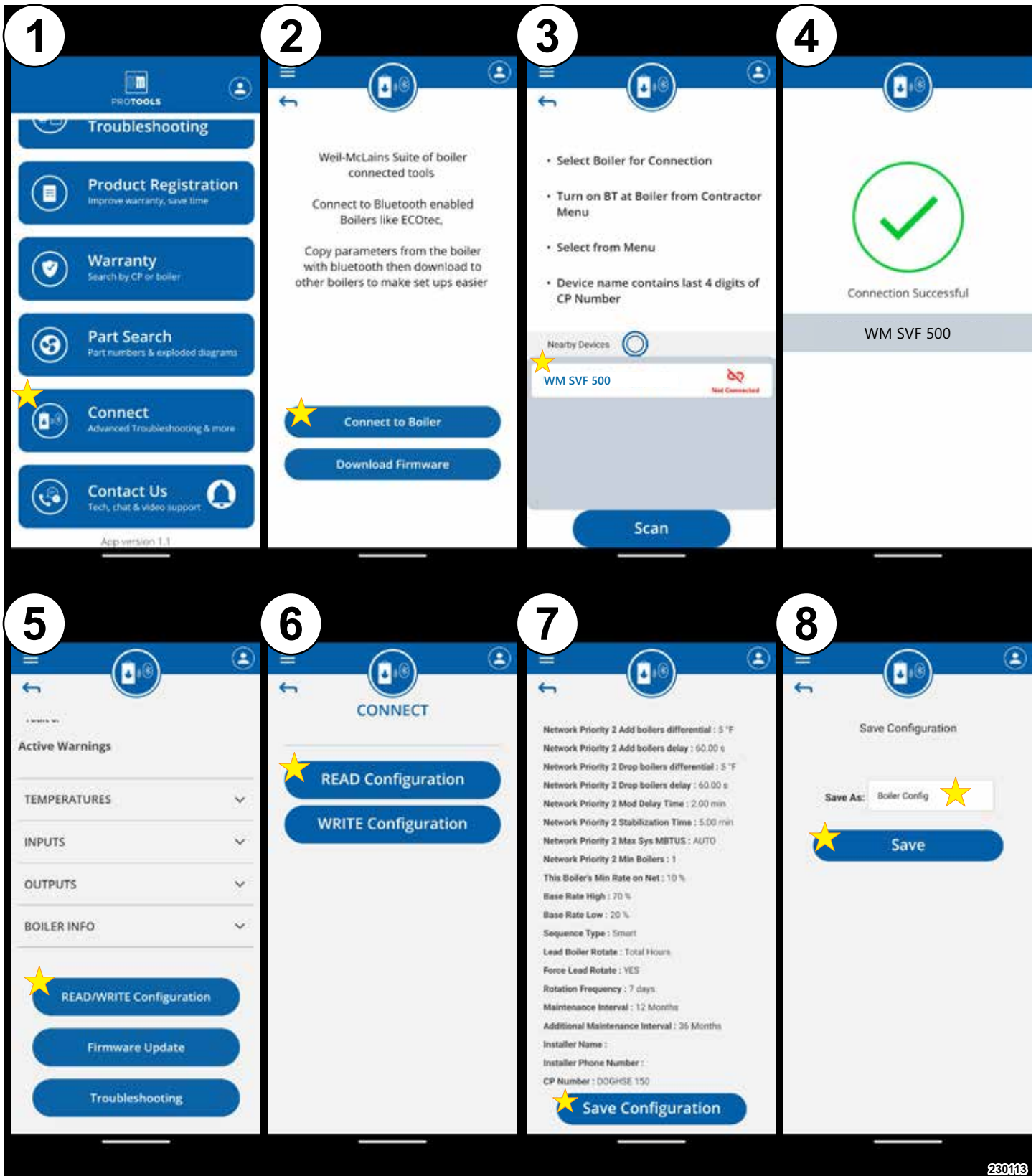

230113

The Control on this boiler now has Bluetooth® capabilities for setup, monitoring & diagnostics. See pages 143 & 144 for further details.

um PROTOOLS™

**TECH SUPPORT
IN THE PALM
OF YOUR
HAND**

Product Info & Troubleshooting
Product Registration
Warranty
Part Search
Connect
Contact Us

GET IT ON
Google Play

Download on the
App Store