

**110/155/220/299/300/399 Series 2
Condensing Gas Boiler**

Advanced Manual

- Multiple boiler installation & settings
- Single boiler advanced settings



⚠ WARNING

Installation and service of the boiler must be performed by a qualified installer or service technician. Read all instructions, including this manual and all other information shipped with the boiler, before installation or operation. Perform steps in the order given. Failure to comply can result in severe personal injury, death or substantial property damage..



Contents

SECTION 1 – Safety

- Abbreviations 2
- Safety Signals 3
- Please Read Before Proceeding 3
 - Servicing a Boiler 3
 - Boiler Operation 3
 - Boiler Water 4
 - Commonwealth of Massachusetts 4
 - Freeze Protection Fluids 4
 - Damage from Water Contact 4
 - Frozen Water Damage 4

SECTION 2 – Setup

- Multiple Boiler Installations 5
 - Placing Multiple Boilers 5
 - Manifolded Combustion Air Option 5
 - Easy-Fit™ Piping Installation 6
- EXPRESS SETUP Requirements 8
 - Control Features 8
 - Sequence of Operation 9
 - Control Priorities & Input/Outputs 9
 - Boiler Circulator 9
 - Control Operation 9
 - Outdoor Reset Operation 10
 - Remote Target Operation (0–10VDC input) 10
 - Remote Modulation Operation (0–10VDC input) 11
 - Variable Speed Boiler Pumping (0–10VDC output) 11
- EXPRESS SETUP Steps 13
- EXPRESS SETUP Wizard 14
- EXPRESS SETUP Multi-Boilers - Example A 19
 - Purpose 19
 - Circulators and Piping 20
 - Field Wiring 21
- EXPRESS SETUP Multi-Boilers - Example B 22
 - Purpose 22
 - Circulators and Piping 23
 - Field Wiring 24
- EXPRESS SETUP Multi-Boilers - Example C 26
 - Purpose 26
 - Control Setting Notes 27
 - Circulators and Piping 27
 - Field Wiring 29
- EXPRESS SETUP Multi-Boilers - Example D 31
 - Purpose 31
 - Control Setting Notes 32
 - Circulators and Piping 32
 - Field Wiring 34
- EXPRESS SETUP Multi-Boilers - Example E 35
 - Purpose 35
 - Control Setting Notes 36
 - Circulators and Piping 36
 - Field Wiring 38
- EXPRESS SETUP Multi-Boilers - Example F 39
 - Purpose 39
 - Control Setting Notes 40
 - Circulators and Piping 40
 - Field Wiring 42

SECTION 3 – Electrical

- Electrical – General 45
 - Power Requirements 45
- Field Wiring 46
 - Wire Entrances 46
 - Wiring Overview 46

- Wire Routing in the Cabinet 47
- Terminal Block Wiring 48
- Wiring Diagram - Schematic 56
- Wiring Diagram - Ladder 58
- Zoning with the Evergreen Pro Control 60

SECTION 4 – Operation

- Control Setup and Operation 63
 - Control Overview 63
 - Multiple Boiler Operation 63
 - Control Setup 64
 - Essential Control Settings 65
 - Control Settings Menus 66
- Available Control Settings and System Presets 67
- NAVIGATION Menu 69
- CONTRACTOR Menus 71
 - Accessing Contractor Menus 71
 - Service Menu Section 71
- BOILER SETTINGS Menus 72
 - Boiler Settings Menus Navigation 72
- PUMP SETTINGS Menu 73
- NETWORK SETTINGS Menu 74
- ROTATION AND SEQUENCE 75
- SYSTEM SETTINGS Menu 77
 - System Settings Menu Navigation 77
- Boiler PRIORITY Menu 78
- AUX Pump/Output 82
- Primary Valve Control 83
- DIAGNOSTICS Menu 84
- SERVICE Menu 86
- SERVICE INFO 86
- Additional Instructions 86

Abbreviations

Table 1 Common abbreviations

Abbreviation	Description
AHD	Additional Heat Demand
AMP	Ampere or Amperage
ANSI	American National Standards Institute
BMS	Building Management System
BTUH	British Thermal Unit per Hour
CAD	Combustion Air Damper
CH	Comfort Heat
CP	Consumer Protection
CSA	Canadian Standards Association
DHW	Domestic Hot Water
LWCO	Low Water Cut-Off
MBH	Thousands of Btuh
NFPA	National Fire and Protection Agency
ODT	Outdoor Temperature
P/T	Pressure and Temperature
VAC	Volts Alternating Current
VDC	Volts Direct Current
WWSD	Warm Weather Shut Down



SECTION 1 Safety

This section is intended to provide safety information.

Section Contents

Safety Signals 3
Please Read Before Proceeding 3

Safety Signals

The following defined terms are used throughout this manual to bring attention to the presence of hazards or other important information.

⚠ DANGER

Danger indicates the presence of hazards that will result in severe personal injury, death, or substantial property damage.

⚠ WARNING

Warning indicates the presence of hazards that can result in severe personal injury, death, or substantial property damage.

⚠ CAUTION

Caution indicates the presence of hazards that will or can result in minor personal injury or property damage.

NOTICE

Notice indicates additional information that may be related to property damage, but is not related to personal injury.

IMPORTANT

Important indicates additional information that is important, but is not related to personal injury or property damage.

Please Read Before Proceeding

⚠ WARNING

Adhere to all following guidelines and instructions in this section. Failure to adhere to these guidelines can result in severe personal injury, death, or substantial property damage.

IMPORTANT

Any claims for damage or shortage in shipment must be filed immediately against the transportation company by the consignee.

Servicing a Boiler

- To avoid electric shock, disconnect all electrical supplies to the boiler before performing maintenance.
- To avoid severe burns, allow boiler to cool before performing maintenance.
- This boiler contains ceramic fiber and fiberglass materials. Refer to the warnings and instructions in the boiler manual (part number 550-100-579).

Boiler Operation

- Do not block flow of combustion or ventilation air to boiler.
- Should overheating occur, or gas supply fail to shut off, do not turn off or disconnect electrical supply to pump. Shut off the gas supply at a location external to the appliance.

(continued on the next page)



Please Read Before Proceeding, continued

Boiler Water

- Since the heat exchanger is made of stainless steel, the water chemistry must be checked. The system pH must be in the range of 7.0 to 8.5. Chemical treatment may be required. See the boiler manual (part number 550-100-579) for details.
- Before connecting the boiler, thoroughly flush the system to remove sediment. Install a strainer or other sediment removal equipment if necessary. The high-efficiency heat exchanger can be damaged by build-up or corrosion due to sediment.
- Do not use petroleum-based cleaning or sealing compounds in the boiler system. Gaskets and seals in the system may be damaged, which can result in substantial property damage.
- Continual fresh make-up water will reduce boiler life. Mineral buildup in the heat exchanger reduces heat transfer, overheats the stainless steel heat exchanger, and causes failure. Addition of oxygen carried in by make-up water can cause internal corrosion. Leaks in the boiler or piping must be repaired at once to prevent make-up water. Use this boiler ONLY in a closed-loop system.
- Do not add cold water to a hot boiler. Thermal shock can cause the heat exchanger to crack.

⚠ WARNING

Boiler Model, Altitude and Fuel Type are critical settings. Failure to set these correctly can result in severe personal injury, death, or substantial property damage.

Commonwealth of Massachusetts

When the boiler is installed within the Commonwealth of Massachusetts:

- This product must be installed by a licensed plumber or gas fitter.
- If antifreeze is used, a reduced pressure back-flow preventer device shall be used.

See the boiler manual for sidewall vent air installations.

Freeze Protection Fluids

NEVER use automotive or standard glycol antifreeze, including glycol made for hydronic systems. Use only freeze-protection fluids recommended in boiler manual. See the boiler manual for more information. Thoroughly clean and flush any replacement boiler system that has used glycol before installing the new Evergreen boiler.

Damage from Water Contact

⚠ DANGER

DO NOT attempt to operate any boiler if any part of the boiler, burner, or controls has been partially or fully sprayed with or submerged under water. The boiler must either be replaced or completely repaired and inspected. The boiler and all components must be in good condition and fully reliable before operation.

If these requirements are not met, operating the boiler will cause fire, explosion, and electrical shock hazards, leading to serious injury, death, or substantial property damage.

Saltwater damage: The immediate effects of saltwater damage are like those of freshwater, with electrical components shorting out and the removal of critical lubricants. However, salt and other contaminants left behind can lead to long term issues due to the conductive and corrosive nature of salt residue. WM Technologies equipment contaminated with saltwater or polluted water will no longer be covered under warranty and should be replaced.

Electrical damage: If any electrical component or wiring has, or is suspected to have come into contact with water, replace the boiler.

Frozen Water Damage

Power outages, unattended residences or buildings, boiler component failures, or other electrical system failures in cold weather can result in frozen plumbing and water damage in a matter of hours. Consult with a boiler contractor or a home security agent to take preventative actions, such as installing a security system that operates during power outages, senses low temperature, and initiates an effective action.



SECTION 2 Setup

Section Contents

Multiple Boiler Installations	5
EXPRESS SETUP Requirements	8
EXPRESS SETUP Steps	13
EXPRESS SETUP Wizard	14
EXPRESS SETUP Multi-Boilers - Example A	19
EXPRESS SETUP Multi-Boilers - Example B	22
EXPRESS SETUP Multi-Boilers - Example C	26
EXPRESS SETUP Multi-Boilers - Example D	31
EXPRESS SETUP Multi-Boilers - Example E	35
EXPRESS SETUP Multi-Boilers - Example F	39

Multiple Boiler Installations

Placing Multiple Boilers

1. Locate multiple boilers with spacings shown in Figure 1. Provide the indicated clearances around boilers for access and servicing.

⚠ WARNING

If recommended dimensions are not possible, provide at least the minimum clearances in the boiler manual and follow local codes. Failure to comply can result in severe personal injury, death, or substantial property damage.

2. If the boiler room floor is uneven or there is a danger of flooding, construct a boiler foundation. Size the foundation to allow for clearance and spacing dimensions shown in Figure 1.
3. Provide a minimum 24" walkway in front of the boilers to ensure accessibility.
4. Uncrate, assemble, and mount boilers according to instructions in the EVG boiler manual.
5. Provide clearances needed for installation of venting, air piping, gas piping, expansion tank, primary circulator, and other accessories. Clearances must comply with all applicable codes.

Figure 1 Side-by-side mounting of multiple boilers - 220-399

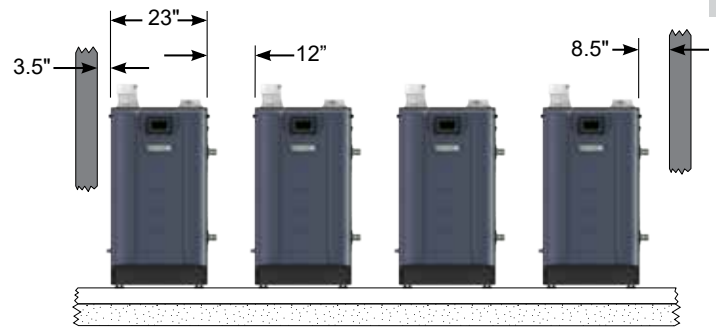
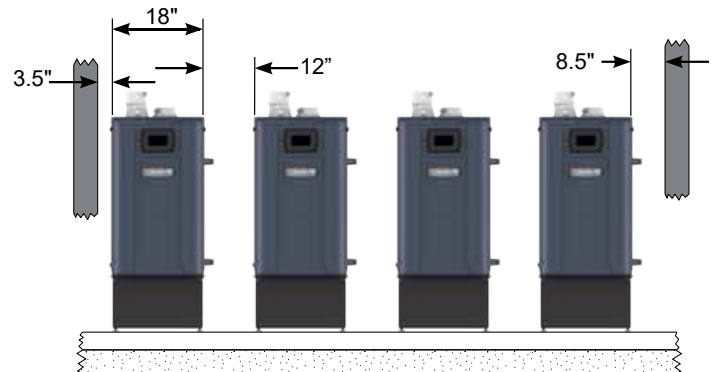

Figure 2 Side-by-side mounting of multiple boilers - 110/155



Manifolded Combustion Air Option

1. Multiple Evergreen boilers can use a common combustion air manifold.
 - a. Provide minimum clearance to adjacent vents and grade/snow line as shown in Figure 2.
 - b. Provide minimum free area in duct (adjusted for louver restriction) of 1 square inch per 2,000 Btuh total boiler input. See the following steps. Also see information in Boiler Ratings section of boiler manual.
 - c. If a combustion air damper is used, wire to boilers to prevent operation, except after damper has opened.

(continued on the next page)



Multiple Boiler Installations (continued)

Manifolded Combustion Air Option (continued)

⚠ WARNING

ONLY air piping can be combined. DO NOT use combined vent piping as flue gas leakage and boiler component damage can occur. Failure to comply can result in severe personal injury, death, or substantial property damage.

- Calculate the required cross sectional area of the combined combustion air duct for area in square inches:

$$\text{MINIMUM DUCT AREA} = \text{TOTAL MBH INPUT DIVIDED BY 2}$$

- Example: A multiple boiler system with three EVG 299 boilers has a total input of $3 \times 299 = 897$ MBH (897,000 Btuh). The required duct cross sectional area would be:

$$\begin{aligned} \text{MINIMUM DUCT AREA} &= 897 \text{ DIVIDED BY 2} \\ &= 448.5 \text{ sq. inches} \end{aligned}$$

Easy-Fit™ Piping Installation

- Main header and Easy-Fit manifold pipe sizing.
 - Size system piping as required for the flow.
 - Install tees on the system piping for Easy-Fit manifolds as shown in Figure 3 or Figure 4. Size manifolds to handle total connected boiler output as shown.
- Provide connections in main header for Easy-Fit manifolds as close as possible to the midpoint of multiple boilers.
 - Use tees for four or less boilers, as in Figure 3.
 - Use either tees (Figure 3) or crosses (Figure 4) for five or more boilers.
- Manifold placement:
 - To alternate spacing for supply and return lines to boilers, reverse the short-end and long-end of the manifolds as shown in Figure 3 and Figure 4 on [page 6](#).
 - The return manifold must be on the return side of the main. The supply manifold must be on the supply side of the main. Drawings in this manual show flow in system main from right to left. For system flowing left to right, reverse the locations of the manifolds accordingly.

Figure 3 Single-sided Easy-Fit header connection

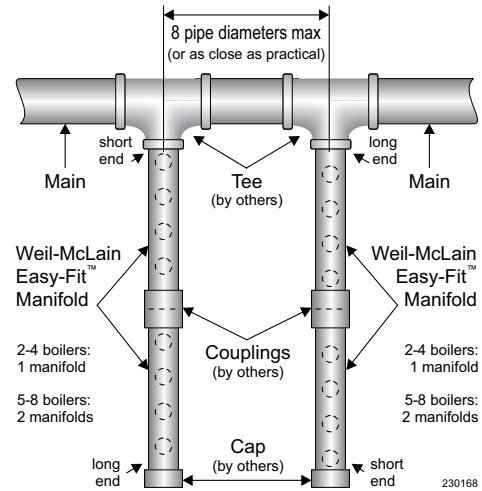
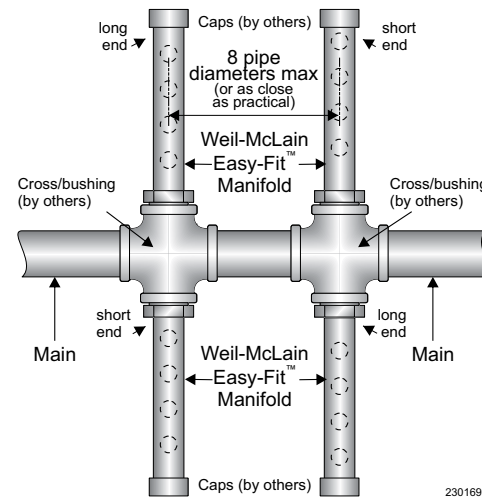

Figure 4 Double-sided Easy-Fit header connection



- Maximum connected load per manifold:
 - 3-inch manifold = 1400 MBH
 - 4-inch manifold = 2900 MBH

IMPORTANT

It is recommended to pipe to boilers such that the first boiler connection off the return manifold is piped to the furthest connection on the supply manifold from the main header. See [Figure 5, page 7](#) for examples.

- Connect from Easy-Fit manifold branches to boiler supply and return connections using copper or steel pipe, sized for the required flow rate.

Multiple Boiler Installations (continued)

Easy-Fit™ Piping Installation (continued)

6. Install an isolation valve on the supply and return of each boiler as shown in the piping diagrams in this manual. Some local codes may require the use of individual water level controls and limits on each boiler because isolation valves are installed.
7. Install main system air eliminator and primary circulator in supply piping as shown in piping diagrams. Place expansion tank on suction side of system circulator as shown.
8. Install system accessories as shown in the figures.
9. Piping recommendation illustrations are as shown. If desired, other primary/secondary piping arrangements can be used:
 - a. Figure 3 and Figure 4 show details of Easy-Fit manifolds.
 - b. Figure 5 is a schematic piping drawing showing the locations of typical boiler piping and system piping, including limits and other devices often required by local codes.
 - c. **Figure 14, page 26** and **Figure 15, page 31** are three dimensional piping drawings of typical multiple boiler installation.
 - d. **Figure 14, page 26** shows recommend piping when an isolation heat exchanger is needed.

Figure 5 Piping schematic - typical piping for multiple EVG boilers using Weil-McLain Easy-Fit manifolds. Adjust boiler connections as required for other boiler models.

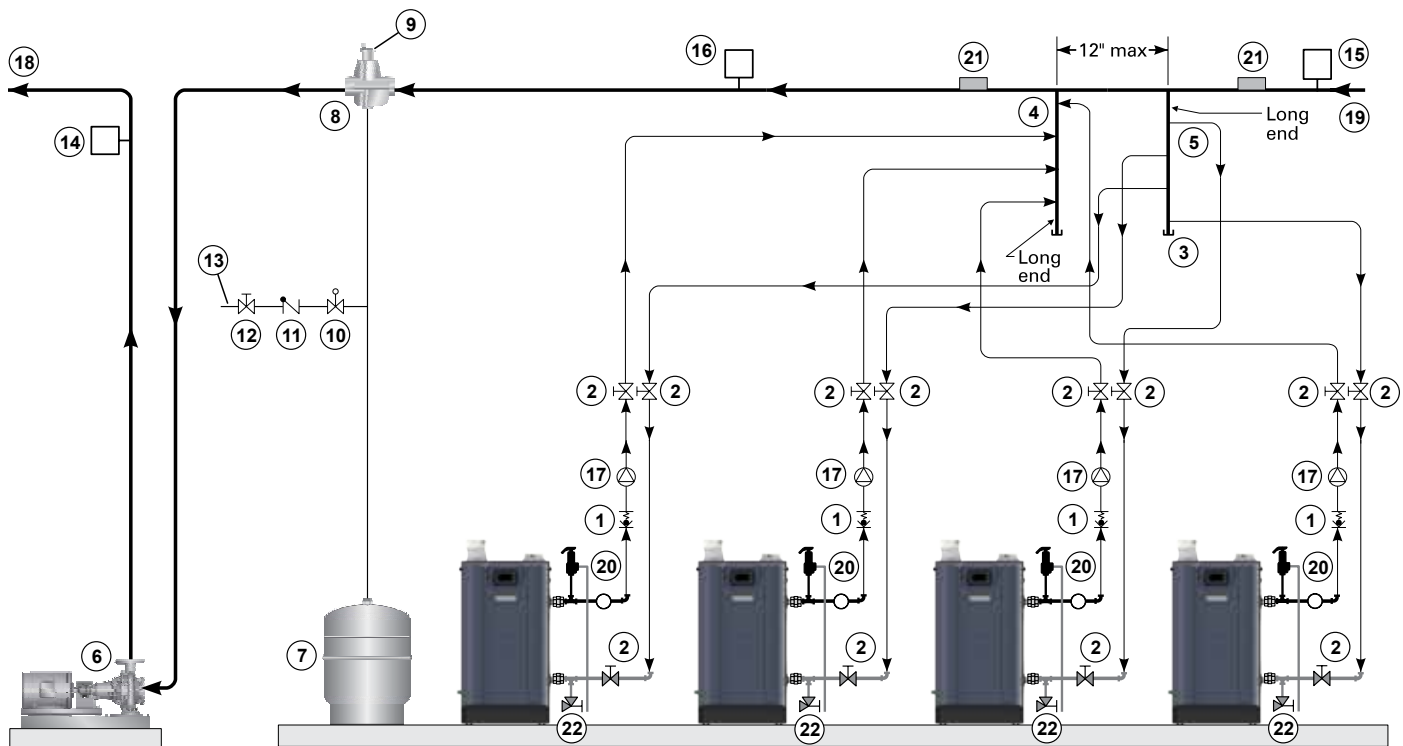

Legend – Figure 5

1. Flow/check or spring check valve.	10. Pressure reducing valve.	17. Boiler circulator.
2. Isolation valves.	11. Check valve or backflow preventer, as required by applicable codes.	18. System supply.
3. Cap.	12. Isolation valve.	19. System return.
4. Easy-Fit® Manifold (supply) — layout and size per page 6 .	13. Cold water supply.	20. Boiler P/T gauge, relief valve and discharge piping, installed per Evergreen boiler manual.
5. Easy-Fit® Manifold (return) — layout and size per page 6 .	14. Supply water temperature control (when used).	21. Strap system supply and return sensors to lines as shown, at least 6 pipe diameters (but no more than 3 feet) from boiler connection tees.
6. Primary circulator.	15. Low water cutoff (when used) (place above primary header).	22. Boiler drain valves.
7. Expansion tank (diaphragm type).	16. Water flow switch (when used) — locate a flow switch in each boiler loop if individual protection is required.	
8. System air eliminator.		
9. System automatic air vent.		



EXPRESS SETUP Requirements

Control Features

- Upload, adjust settings, and perform easier diagnostics via wireless communication.
- Color touch-screen display for ease of operation monitoring and troubleshooting.
- Easy configuration with Wizard step-by-step setup including on-screen help.
- The control can communicate to other controls and to existing Unity™ and Unity™ 2 controls in a multi-boiler network.
- Three programmable priority assignments for up to four heat inputs.
- Preset operating parameters for typical heating systems, including target temperatures, reset curves and circulator assignments.
- Integral outdoor reset option, with reset curves matched to the system type selected.
- Modbus communications for external communication and monitoring.
- 0-10 Vdc input modulation or remote target input.
- Five configurable outputs, including one boiler circulator output.
- Additional heat demand operation to call a second heat source to help supply the energy required for heating.
- Advanced PI response to anticipate system needs.
- Flue temperature modifier to target temperature.
- Modulation based on flue sensor and boiler out sensors.
- Dual temperature sensors on boiler outlet and flue, providing redundant protection.
- Boiler is shipped with an outdoor sensor.
- Blower speed modulation to control boiler firing rate.
- Alarm relay on error/fault for use with an audible safety.
- Blower calibration – allows fine tuning of blower control to reach purge speeds faster, reducing time to heat delivery.
- Temperature units – Select between using °F or °C.
- Manual Reset High Temperature Limits – Set High Limit temperature safety value.
- Daylight Saving Time – Select whether your boiler will obey Daylight Savings Time for your region.
- 0-10 Vdc Output to control classic lead/lag systems and variable speed boiler pumps.

Figure 6 Control sequence of operation

Display status text	Control action (Also see Figure 22, page 66)
POWER UP	<ul style="list-style-type: none"> • Check the boiler model listed on the power-up screen. If it is not correct, turn off the boiler. See page 63 for instructions to change setting. • When power is turned on, the screen lists sensors that are detected. If any sensor is not listed, make sure it is connected correctly. Turn off power and restart.
Standby	<ul style="list-style-type: none"> • Standby – no calls for heat. • Toggles through zero dots up to three dots while in standby (wrench symbol will show instead if maintenance is needed).
Blower Prepurge	<ul style="list-style-type: none"> • Call for heat detected. • Display on with BLUE (space heating) or PURPLE (DHW) banner. • Start min/max timers if more than one system is calling - highest priority starts first. • Start circulators for this priority setup based upon settings. • Calculate target temp – If sensor temp is below target temp, begin firing sequence. • Blower to ignition speed for prepurge.
Ignition	<ul style="list-style-type: none"> • After prepurge times out, begin ignition cycle. • Activate gas valve and ignition spark. • Continue ignition spark for ignition period. • Turn off spark and use electrode to check for flame signal.
Space Heating	<ul style="list-style-type: none"> • Flame detected. • Release boiler to modulation. • NOTE: If flame is not detected, the gas valve is turned off, blower turns on (postpurge), and control starts cycle again. After five failures, the control waits 60 minutes, then tries again. • If priority timer times out, switch to next priority and start priority timer. • If demand satisfied, go to postpurge.
DHW Heating	<ul style="list-style-type: none"> • Flame detected. • Release boiler to modulation. • NOTE: If flame is not detected, the gas valve is turned off, blower turns on (postpurge), and control starts cycle again. After five failures, the control waits 60 minutes, then tries again. • If priority timer times out, switch to next priority and start priority timer. • If demand satisfied, go to postpurge.
Blower Postpurge	<ul style="list-style-type: none"> • Demand satisfied (temperature reaches target temp or limit setting). • Gas valve off. • Blower to ignition speed for postpurge. • Return to standby after purge.
Maintenance	<ul style="list-style-type: none"> • Display banner turns BLUE, toggling between graphic screen and maintenance screen if maintenance schedule timer times out. • Will show during standby only. • Boiler operates as normal.
Error/fault	<ul style="list-style-type: none"> • Display banner turns RED due to error or limit event.
WWSD	<ul style="list-style-type: none"> • Warm weather shut down - the boiler is not allowed to fire on space heating if the outdoor temperature is greater than the WWSD setting. • DHW operation is not affected by WWSD.

EXPRESS SETUP Requirements (continued)

Sequence of Operation

Figure 6, page 8 is a summary of the operating sequence for the control.

- The statuses shown appear in the display as the control cycles the boiler.
- The display banner will be red if a problem has been detected.

Control Priorities & Input/Outputs

For heating installations with multiple systems, the control uses PRIORITIES to determine the order of operation of the systems.

- The control's MAX and MIN time settings determine the maximum and minimum times a system will be operated before being turned off to allow another system to operate.
- A typical example is DHW priority — heat demand from the DHW system is given preference over space heating, if set to use Priority 1.
- The MAX ON TIME setting controls the maximum time a priority will be allowed to run before switching to a lower priority's call for heat.
- The MIN ON TIME setting controls the minimum time a priority will be operated before switching to a higher priority's call for heat, or the next lower priority.
- Each PRIORITY has its own set of operating parameters.
- The control prompts the user to select the system type (finned tube baseboard, DHW, etc.) and is factory programmed with parameters suited to each of these system types.
- The user can also choose CUSTOM to create a system type.
- The 120VAC power output to the boiler circulator is provided by the boiler's control board.
- The control provides up to three (3) priorities for single boiler applications and up to four priorities for network boiler applications. The order of operation is:
 - Single boilers: PRIORITY 1, PRIORITY 2, PRIORITY 3.
 - Network boilers: LOCAL PRIORITY 1, NETWORK PRIORITY 1, NETWORK PRIORITY 2, LOCAL PRIORITY 2.
- For each boiler in a network, this provides up to two (2) local priorities, used for heating systems piped directly to the boiler, such as DHW tanks.
- Network priorities are used for heating systems connected in the primary heating loop and supplied by the boiler network.
- Each boiler has up to four (4) input/output pairs (INPUT/OUTPUT 1, 2, 3 and 4).
- Control setup prompts the user to assign each of these I/O pairs to a PRIORITY. The control then knows which system (priority) to operate when the input receives a call for heat. On a call for heat to an input, the control closes the corresponding output (120VAC) and begins controlling the boilers according to the setup for the assigned priority.
- When multiple inputs are set up on the same priority, they will run at the same time if the priority and inputs are active.

Boiler Circulator

- The boiler circulator is supplied with the boiler.
- The 120VAC Output for the boiler circulator is located on the terminal strip located on the High Voltage Terminal Bracket (110/155) or in the High Voltage Terminal Tray (220-399). For each of the priorities, the control can be setup to run the boiler pump or to leave it off. It is recommended to set Boiler Circulator to OFF for directly piped DHW systems with its own circulator.

WARNING

The boiler circulator must be installed and connected. Flow through the boiler must be provided during all times of operation. Failure to do so can result in severe personal injury, death or substantial property damage.

Control Operation

The control responds to signals from:

- Room thermostats.
- DHW aquastats (if used).
- Temperature sensors Boiler Out, Boiler In, flue temperature and when used, outdoor temperature.
- It is required to install System Supply and Return sensors for proper design operation.
- The control automatically adjusts blower speed to match boiler output to heating demand.
- The control provides up to four (4) inputs and four outputs (for circulators or auxiliary devices) plus a fifth (5) boiler circulator output based on selected boiler model.
- Outdoor reset are recommended to be used in all application.
- The outdoor temperature is used for supply temperature reset operation and for the warm weather shutdown (WWSD) option.
- See "Outdoor Reset Operation" on page 10 for complete explanation of outdoor reset settings.
- System presets:
 - The control provides presets by system type for complete list, see **Table 10, page 68**.
 - The control provides up to four space heating zones. The control can be easily set up for operation with a DHW zone, with or without domestic priority.
 - The Wizard leads through a step-by-step setup procedure designed for the application chosen.
 - Context-sensitive help is available to explain the purpose of key setup items.



EXPRESS SETUP Requirements (continued)

OUTDOOR TEMP FOR MIN TARGET

1. OUTDOOR TEMP FOR MIN TARGET means the outdoor temperature at which the target temperature reaches its minimum (Min Target Temp).
2. In the examples of Figure 7, this occurs at 70°F (the factory default).

OUTDOOR TEMP FOR MAX TARGET

1. OUTDOOR TEMP FOR MAX TARGET means the outdoor temperature at which the target temperature reaches its maximum value (Max Target Temp).
2. In the examples of Figure 7, this occurs at 0°F (the factory default setting).
3. OUTDOOR TEMP FOR MAX TARGET should equal the Outdoor Temp (outdoor design temperature) for the installation's location.

Outdoor Reset Operation

1. Set desired temperatures for space heating zones.
2. For an explanation of the target temperatures and associated outdoor temperatures, see Figure 7.
3. The temperature settings discussed below are accessed in the priority menu for the applicable system. For detailed explanations of the priority menus, see [Figure 32, page 78](#).

MAX TARGET TEMP

Set Max Target Temp to the required supply water temperature for the system at design maximum heat loss (typically 180°F for finned tube baseboard on new installations).

MIN TARGET TEMP

1. Min Target Temp should equal the desired minimum supply water temperature for the system.
2. The Min Temp is the setpoint whenever the ODT temp is above the ODT For Min Target and below the WWSD temps.

NOTICE

Setting this value below the Outdoor Temp for Min Target may reduce the performance of the heating system at warmer outdoor temperatures.

3. This could be set as low as 60°F, which would supply “zero heat” when outdoor temperature is 70°F, because supply water temperature would close to room temperature. See examples in Figure 7.

Figure 7 Outdoor reset operation

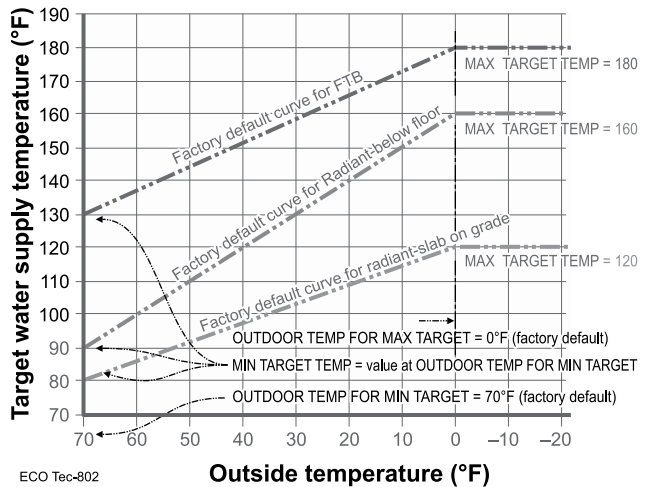
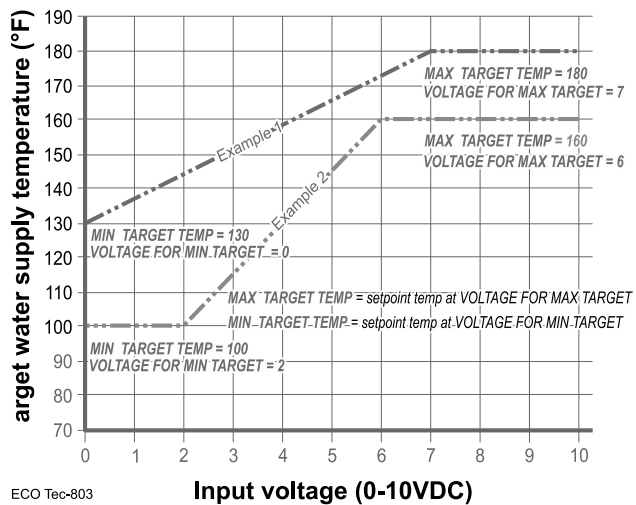

Figure 8 Remote target operation



Remote Target Operation (0–10VDC input)

1. This function allows a remote analog input to regulate the supply temperature for control operation/modulation. This can be done for any priority.
2. The settings discussed below are accessed in the Priority menu for the applicable system. For detailed explanations of the Priority menus, see [Figure 32, page 78](#).

EXPRESS SETUP Requirements (continued)

3. See Figure 8 for an explanation of target temperature vs voltage when using remote target operation.
 4. In the priority menu for the applicable system, select 0-10V for the TARGET ADJUST setting.
 5. In the same priority menu, select the VOLTS FOR MIN TARGET and VOLTS FOR MAX TARGET values. VOLTS FOR MIN TARGET sets the voltage value for the desired minimum supply temperature. VOLTS FOR MAX TARGET sets the voltage value for the desired maximum supply temperature.
2. Operation – Variable Speed Boiler Pump. See [page 73](#) for more details.
 - a. VARIABLE SPEED MAX RATE VOLTS is desired voltage delivered to the pump when at high fire.
 - b. VARIABLE SPEED MIN RATE VOLTS is desired voltage delivered to the pump when at low fire.
 - c. VOLTS WHEN BURNER OFF is desired voltage delivered to the pump when the burner is not active.
 - d. When the burner is active, the voltage output scales based on the boiler rate and the constrains of VARIABLE SPEED MIN/MAX RATE VOLTS.

Remote Modulation Operation (0–10VDC input)

1. To use 0-10VDC for remote modulation, go to Contractor Menu -> System Settings -> select the appropriate priority. Select Input 2 from System Setting menu, then change Input 2's source to 0-10V. The priority that is assigned to Input 2 cannot be used by any other Input. Only applicable for Single boilers. Network cannot use 0-10V remote modulation.
2. The boiler comes on at 0.9VDC and turns off at 0.5VDC. 1 VDC = 10% input. 10VDC = 100% input. These voltage settings are adjustable.

Variable Speed Boiler Pumping (0–10VDC output)

1. Control Setup – Variable Speed Boiler Pump.
 - a. 0-10VDC Output functionality allows for control of a variable speed boiler pump.
 - b. Connect the output to 0-10VDC input of the pump. See [page 54](#) for more details.
 - c. From the Contractor menu, navigate to Diagnostics -> Manual Test Mode. See [Figure 9, page 11](#). With FORCE RATE highlighted, select <EDIT> then use the arrows to force to <HIGH> and press <SAVE>.
 - d. Adjust the desired voltage to the desired delta T on the boiler and <SAVE AS MAX VOLTS>, Change the Pump Volts setting to AUTO to edit FORCE RATE again. Repeat for each FORCE RATE speed. Ignition speed rate sets voltage delivered to the pump when the burner is not active.

Figure 9 Manual test mode screen

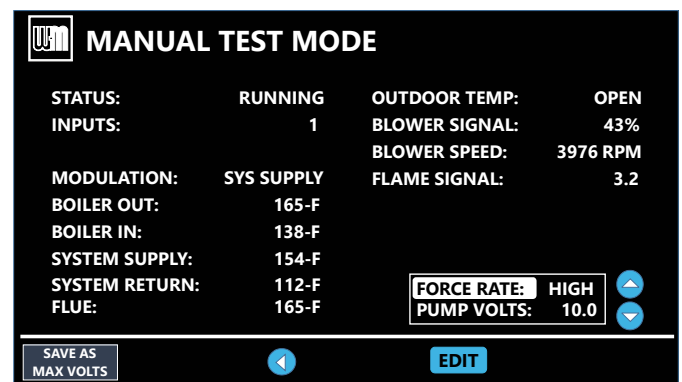



EXPRESS SETUP Requirements (continued)

Figure 10 Pressure drop through Evergreen (EVG) heat exchanger

EVG 110			EVG 155			EVG 220			EVG 299/300			EVG 399		
Flow Rate (GPM)	Head Loss (ft. w.c.)	ΔT (°F)	Flow Rate (GPM)	Head Loss (ft. w.c.)	ΔT (°F)	Flow Rate (GPM)	Head Loss (ft. w.c.)	ΔT (°F)	Flow Rate (GPM)	Head Loss (ft. w.c.)	ΔT (°F)	Flow Rate (GPM)	Head Loss (ft. w.c.)	ΔT (°F)
5**	0.3	40***	7**	0.39	41***	10**	0.00	45***	13**	0.0	45***	18**	0.0	45***
6.5	0.51	31	9	0.65	32	12	0.00	37***	18	0.3	33	24	0.3	33
8	0.77	25	11	0.97	26	14	0.1	31	22*	0.6	27	28*	0.7	29
10*	1.2	20	13	1.35	22	16	0.2	28	28	1.2	21	32	1.1	25
			14.5*	1.68	20	18*	0.2	24	32	1.7	19	36	1.6	22
						20	0.3	22	-	-	-	40	2.2	20
						22	0.5	20	-	-	-	-	-	-

Note: Delta Temperatures above are based on Boiler running on High Fire

* Suggested design flow rates based on a 20°F (EVG 110/155), 25°F (EVG 220/299/300) and 30°F (EVG 399) temp rise through the boiler.

** Minimum Flow Rates at high fire (GPM):

EVG 110: High Fire = 5.0, Low Fire = 2.1

EVG 155: High Fire = 7.0, Low Fire = 2.9

EVG 220: High Fire = 10, Low Fire = 2.4

EVG 299/300: High Fire = 13, Low Fire = 3.2

EVG 399: High Fire = 18, Low Fire = 4.0

***Temp Rises above 35°F are not recommended in high temp systems; larger Boiler Out on/off Diff's may be required for proper operation

Notice: Boilers are designed to reduce firing rate when differential temperature reaches 50°F. When using boiler in a modulating flow, the minimum allowable water flow rate during low fire operation is listed above. The variable speed pump must control flow between minimum and full rate in accordance with firing rate. See Faults and Action Items beginning on page 157 in the Boiler Manual.

Figure 11 Flow rates for **0.04 feet head loss per foot** of pipe (140°F water)

Pipe size (inches)	MAX Flow rate (GPM) @ 0.04 feet per foot	Pipe size (inches)	MAX Flow rate (GPM) @ 0.04 feet per foot
¾	3.9	2	45
1	7.1	2½	75
1¼	16	3	140
1½	24	4	290



EXPRESS SETUP Steps

⚠ WARNING

The Wizard must be used when using the EXPRESS Setup procedure to ensure that all required settings are made. All instructions in the boiler manual must be followed completely. Failure to comply can result in severe personal injury, death, or substantial property damage.

<p>Step 1 Mechanical</p>	<ul style="list-style-type: none"> Install boiler(s) per the boiler manual and all applicable codes, including vent/air piping and water piping. See suggested piping in this manual and boiler manual. 	<ul style="list-style-type: none"> As shown in the suggested piping examples, DHW tanks can be either piped directly off of individual boilers or as a separate zone in the heating system. See page 19 for additional information on multiple boiler installation options.
<p>Step 2 Electrical</p>	<ul style="list-style-type: none"> For details, see the Field Wiring section. <p>BOILER POWER SUPPLY</p> <ul style="list-style-type: none"> Connect 120 VAC power to boiler as directed on the boiler wiring diagram (on boiler and on page 56). <p>INPUTS & OUTPUTS</p> <ul style="list-style-type: none"> Each boiler provides four input/output pairs. Input circuits are 24 VAC. DO NOT apply voltage. Use dry contacts only. Circulator outputs 1-4 are 120 VAC, 2.0-amps max (use relays if loads exceed 2.0 amps or if outputs must be 24 VAC or must be isolated contacts and 120VAC, 2.2-amps max for the boiler circulator output). The input/outputs can be used with zone thermostats and zone circulators or zone valves (requires isolation relays unless valves are 120 VAC), providing up to four zones per boiler on a multiple system. If required, the AUX PUMP/OUTPUT feature can turn any of the input/outputs into a customized output with many operation types. This should be used for system pumps which operate independently from a heat demand or when multiple inputs should activate a common output. Setup can be done through the WIZARD or manually in System Settings, Input menu. 	<p>SENSORS</p> <ul style="list-style-type: none"> Connect an outdoor sensor, system supply sensor and system return sensor to at least one of the boilers in a multiple boiler system. Preferably, connect outdoor, system supply and system return sensors to more than one boiler to provide redundancy. If one of the sensors fails, the master boiler control automatically looks for an available sensor. <p>MULTIPLE BOILER COMM CABLES</p> <ul style="list-style-type: none"> For multiple boilers, connect boiler-to-boiler communication cables as directed in Section O, page 55. <p>ADDITIONAL INFORMATION</p> <ul style="list-style-type: none"> For flow switch or CAD interlock wiring, see Section K, page 53. For external limit connections, see Section G, page 51. For low water cut-off connections, see Section H, page 52. For 0–10 VDC inputs, see Section L, page 53 and Section M, page 54. For 0–10 VDC outputs, see Section N, page 54. <p>ZONING METHODS</p> <ul style="list-style-type: none"> See wiring and control setup information for typical zoning applications beginning on page 60. See example systems beginning on page 19.
<p>Step 3 POWER ON</p>	<p>IMPORTANT</p> <p><i>Follow all instructions in the boiler manual, including all start-up inspections and final checks.</i></p> <ul style="list-style-type: none"> Turn OFF the manual gas cock at the boiler to prevent gas flow during setup. 	<ul style="list-style-type: none"> Turn the boiler ON. Follow the prompts on the screen to reach the BOILER SETTINGS initial start-up screen. See Figure 21, page 65 for navigation information. Note that the screen sequence changes after initial setup, as shown.
<p>Step 4 Wizard</p>	<ul style="list-style-type: none"> Select the START WIZARD option when prompted. See page 14. Alternatively, select 'Use App' if a pre-configured setup is already created via the ProTools app. Use on-screen help as needed. For additional information, see details in this manual. 	<p>DO NOT select SKIP WIZARD unless the control is to be configured manually.</p>
<p>Step 5 Finish setup</p>	<ul style="list-style-type: none"> Some additional control settings may need to be changed, depending on the application. 	<ul style="list-style-type: none"> See explanation of control operation and settings, beginning on page 63.
<p>Step 6 Start-up</p>	<ul style="list-style-type: none"> Apply the boiler manual instructions to verify the installation and to start up the boiler, using combustion test instruments as directed. 	



EXPRESS SETUP Wizard

The Wizard is available on the initial setup of the boiler. It can however be accessed later.

If the Wizard is accidentally by-passed, follow navigation sequences shown on [page 71](#). Select <RESET FACTORY DEFAULTS> on the Boiler Settings menu. Select <RESTART Wizard> and follow screen directions. Boiler setup must then be started over from the beginning.

The Wizard leads through a step-by-step setup procedure designed for the application chosen. Context-sensitive help is available to explain the purpose of key setup items.

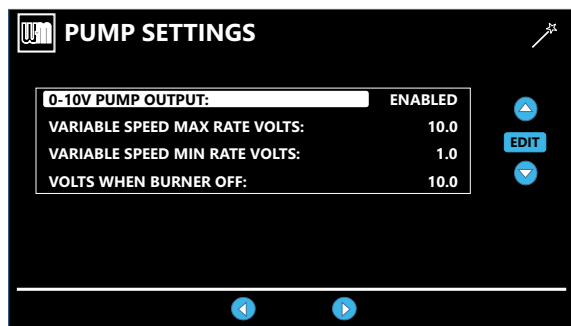
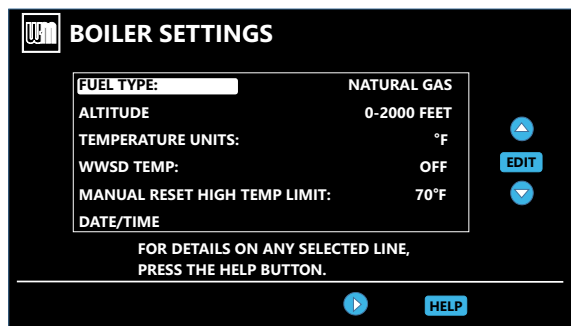

MENU Item	PURPOSE
BOILER SETTINGS WIZARD SCREEN	<ul style="list-style-type: none"> This screen appears on initial start-up. Perform the WIZARD steps for every boiler. ALTITUDE and FUEL TYPE are critical parameters. They must be entered correctly for each boiler before proceeding. Enter the WWSD temperature – This sets the outside temperature below which Space heating systems will be disabled. WWSD must also be selected during system setup to enable it. Manual Reset High Temperature Limit acts as a temperature safety. Exceeding this temperature control will enter lockout and require a manual reset to continue.
PUMP SETTINGS	<ul style="list-style-type: none"> CIRCULATOR EXERCISING allows the user to select which circulator outputs should energize for a brief time after 72 hours of boiler inactivity. FREEZE PROTECT CIRCULATORS allows the user to select which circulators should activate when the boiler in and/or boiler out sensors drop below 40°F. Turning off boiler circulators disables this feature. 0-10V PUMP OUTPUT enables and disables using the 0-10 VDC output for use with variable speed pump control. All options can be set later by using the Manual Test Mode Force Rate to adjust and save the desired voltage output for each setting. See Manual Test Mode section on page 73 for further details. VARIABLE SPEED MAX RATE VOLTS sets the output voltage of the 0-10 VDC output when the boiler is operating at maximum rate. VARIABLE SPEED MIN RATE VOLTS sets the output voltage of the 0-10 VDC output when the boiler is operating at minimum rate. VOLTS WHEN BURNER OFF sets the output voltage of the 0-10 VDC output when the boiler has a call for heat, but does not need to fire its burner. The pump also runs at this voltage when the boiler is in Standby, Pre-pump, Pre-purge and Post-purge/ Post-pump states. It will transition to mirroring rate based on Variable Speed Max/Min Rate Volts constraints and the actual blower speed when in Ignition Speed state and all burner-active states.
STARTUP WIZARD SCREEN	<ul style="list-style-type: none"> SELECT USE WIZARD. Alternatively, if a pre-configured setup has been created previously, select Use App to use the ProTools app to upload the configuration. DO NOT select SKIP WIZARD. Selecting SKIP WIZARD will take the screen to the USER MENU. All setup would then have to be done manually.

Screens shown on this page are typical only. Actual screens depend on control settings chosen.

(continued on the next page)



EXPRESS SETUP Wizard (continued)

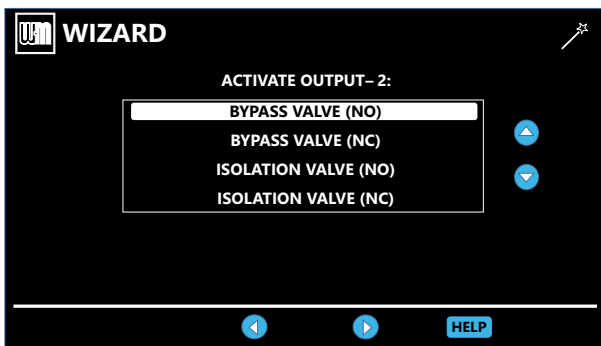
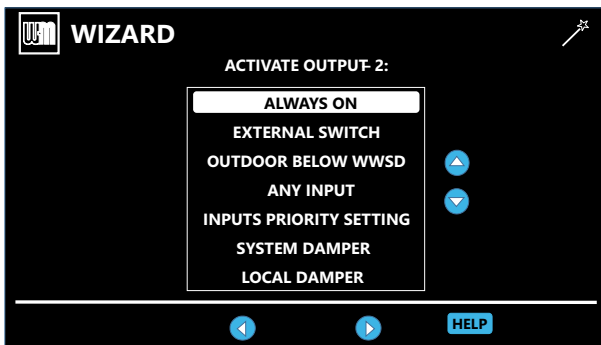
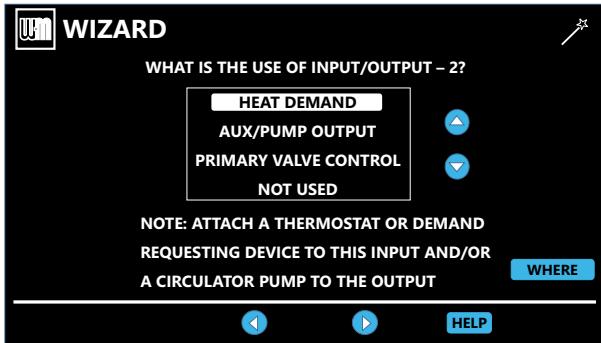

MENU Item	PURPOSE
<p>INPUT/ OUTPUT WIZARD SCREEN</p>	<ul style="list-style-type: none"> Each boiler provides four input/output pairs. Each pair can be setup to function as a call for heat with output or to perform as an auxiliary function, such as operating a system pump. After the WIZARD screens are completed for INPUT 1, the WIZARD starts over with INPUT/ OUTPUT 2, then to INPUT/OUTPUT 3 after 2 is completed, followed by INPUT/OUTPUT 4. Select HEAT/DHW DEMAND if the input/output is connected to a heating or DHW zone or system. The input could be a zone thermostat or end switch. The output could be 120 VAC to a circulator (2.0 amps or less) or isolation relay. Select AUX PUMP/OUTPUT, use this screen to set when a AUX PUMP/OUTPUT is activated. For detailed explanation, see page 82 if the input is to be used for a system pump, combustion air damper interlock, etc. To operate a system pump, setup the input as AUX PUMP/OUTPUT. Connect the corresponding output to the system pump or pump relay (if pump load exceeds 2.0 amps). When the ACTIVATE OUTPUT # screen appears, select the setting applicable to your application. Select PRIMARY VALVE CONTROL if the system uses bypass or isolation valves. For detailed explanation, see Figure 36, page 83, or on-screen in the WIZARD HELP menu for each option. This option is only available for Master/Shadow boilers. Select NOT USED if the input/output is not needed.

2



EXPRESS SETUP Wizard (continued)

2

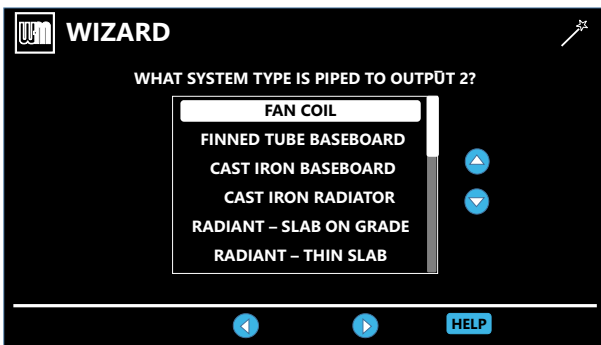
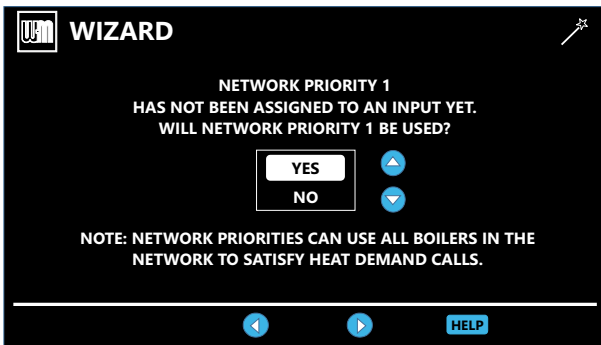
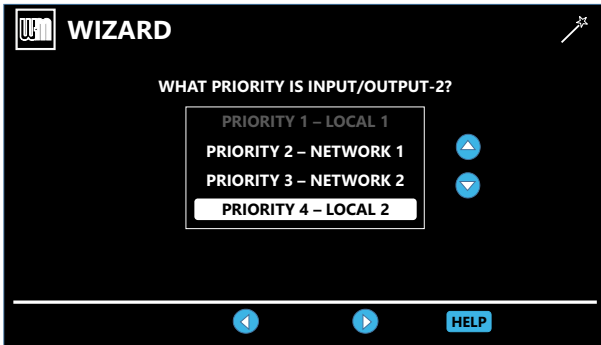

MENU Item	PURPOSE
<p>PRIORITY SELECTION WIZARD SCREEN</p>	<ul style="list-style-type: none"> For multiple boiler applications, the control provides up to four priorities, as listed on this screen. Preference is given to these priorities in the order shown (Priority 1 through 4). Select which priority will be operated by this input/output. All boilers can operate on demand from Network priorities. <p>NETWORK PRIORITIES:</p> <ul style="list-style-type: none"> Any input on any boiler can be assigned to a network priority (NETWORK PRIORITY 1 or NETWORK PRIORITY 2). The WIZARD will only allow settings to a Network Priority on the Master Boiler. It will skip setting up a Network Priority on all shadow boilers. All boilers on the network will fire to meet network demands. The Network Priority Not Assigned screen only appears when a Network Priority is not setup on the Master. <p>LOCAL PRIORITIES:</p> <ul style="list-style-type: none"> Any boiler can use its input/outputs to operate up to two local priorities (LOCAL PRIORITY 1 and LOCAL PRIORITY 2). This applies only for heating loops directly piped to the boiler. Local demands are only satisfied by the boiler to which the input is wired. Local heating loops must be directly piped to the boiler. Single boilers use Local 1, Local 2 and Local 3 in place of network calls
	<p>SYSTEM TYPE WIZARD SCREEN</p>

Screens shown on this page are typical only. Actual screens depend on control settings chosen.

(continued on the next page)



EXPRESS SETUP Wizard (continued)

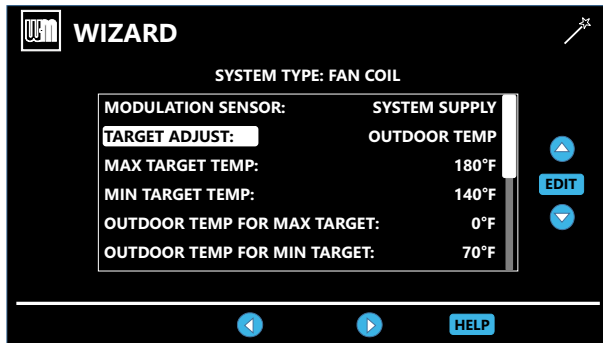

MENU Item	PURPOSE
<p>PRIORITY SETTINGS WIZARD SCREEN</p>	<ul style="list-style-type: none"> • SYSTEM TYPE – Read only (assigned in previous step). • TARGET MOD SENSOR – Read only for network boilers, adjustable for single boilers – Shows which sensor reading is used for modulation. Boiler sensor is default for local priorities. System sensor is default for network priorities. • TARGET ADJUST – Select how target temperature is calculated: <ul style="list-style-type: none"> NONE (No reset, fixed target temp = MAX TARGET TEMP) ODT (Outdoor reset operation; default setting). Target temperature is calculated from the outdoor reset curve. MAX TARGET TEMP is target temperature when outside temperature equals Outdoor temp for MAX target. MIN TARGET TEMP is target temperature when outside temperature equals Outdoor temp for MIN target. At outdoor temperatures in between, target temperature is scaled proportionally. 0–10V (Target temperature based on input from remote source). MAX TARGET TEMP is target temperature at VOLTAGE FOR MAX TARGET value. MIN TARGET TEMP is target temperature at VOLTAGE FOR MIN TARGET value. For voltage values between max and min, target temperature is scaled proportionally. • MAX TARGET TEMP – Set MAX TARGET TEMP to the required supply water temperature for the system at design maximum heat loss (typically 180°F for finned tube baseboard on new installations). • MIN TARGET TEMP – MIN TARGET TEMP should equal the desired minimum supply water temperature for the system. This line will not show if TARGET ADJUST is selected as NONE. • OD RESET MAX – means the outdoor temperature at which the target temperature reaches its minimum (MIN TARGET TEMP). (Does not appear if 0–10V is selected for TARGET ADJUST). • OD RESET MIN – means the outdoor temperature at which the target temperature reaches its maximum value (MAX TARGET TEMP). (Does not appear if 0–10V is selected for Target Adjust). • VOLTAGE FOR MAX TARGET – Appears if 0–10V is selected for Target Adjust. Set the voltage at which Supply Max temp is required. • VOLTAGE FOR MIN TARGET – Appears if 0–10V is selected for Target Adjust. Set the voltage at which MIN TARGET TEMP temperature is required. For voltages between Min and Max, the target temperature will be adjusted on a linear curve. • BOOST TIME – Every time the call for heat surpasses this duration of time the target temp will boost up 10°F. It will cap off at Supply Max. Only active if a reset curve via Target Adjust setting is being used. • RUN 120V BOILER PUMP – Selects whether the Boiler Pump is turned on while running on this call for heat. This setting is YES for network priorities and is not adjustable. • RUN AUX PUMP/ OUT – Selects whether Inputs/Outputs in the system configured as AUX PUMP/OUTPUT are turned on while running on this call for heat. • MAX ON TIME / MIN ON TIME – Maximum or minimum time the network will run on this priority if it is being asked to run on another network priority. MAX shows for Network Priority 1, MIN shows for Network Priority 2. This line ONLY shows on the Master boiler Wizard. It does not appear on Shadow boilers.





EXPRESS SETUP Wizard (continued)

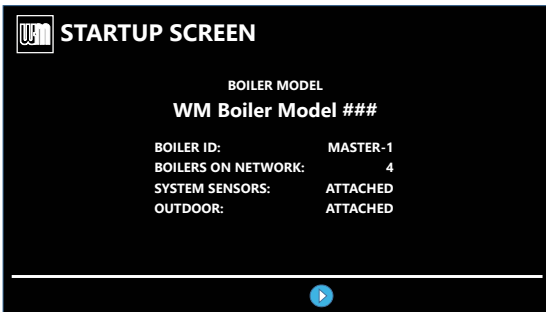
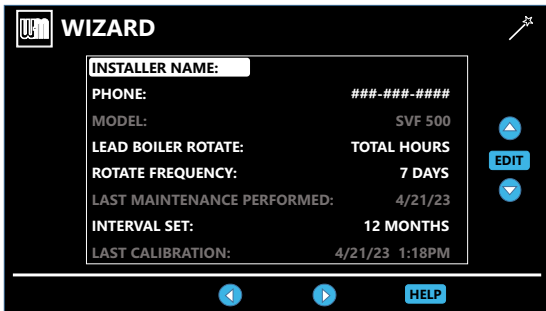
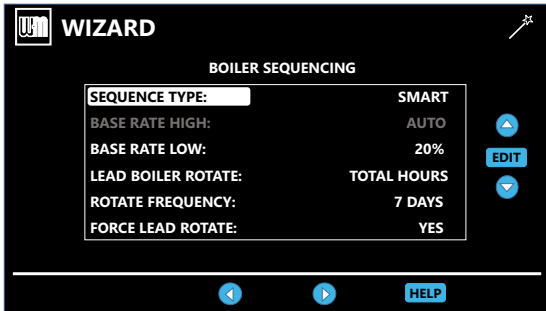

MENU Item	PURPOSE
PRIORITY TIMERS WIZARD SCREEN	<ul style="list-style-type: none"> The timings set on this screen prevent the boiler from operating too long on one demand if another demand is present. They also prevent short cycling on a demand. L1 and L2 are times for local priorities. NET MIN ON TIME and NET MAX ON TIME are the maximum and minimum times this boiler will dedicate to a call from a network demand. Net Min and Max are replaced by L2, and L2 Min is replaced by L3 Min for a Single boiler.
SEQUENCE TYPE WIZARD SCREEN	<ul style="list-style-type: none"> Use this screen to set how boilers are sequenced and how usage is rotated between boilers on the network. For a complete explanation of Sequencing and Rotation, see pages 75-76. Sequencing means the way in which boiler firing rate is controlled as boilers are turned on and off by the Master boiler. With the default settings, SMART SEQUENCING maximizes efficiency when adding boilers to the network. It runs more boilers to satisfy the demand. Boilers added start at the user-set Base Rate Low. With the default settings, PARALLEL SEQUENCING balances efficiency and number of boilers running. Each boiler modulates up to the user-set Base Rate High before adding another boiler. With the default settings, SERIES SEQUENCING minimizes the number of boilers running. Each boiler modulates to its Max Rate before adding another boiler. Rotation means how and how often the boiler firing order is changed. LEAD BOILER ROTATE options are based on how long a boiler has operated. Select either OFF, BY BOILER ID, TOTAL HOURS or INCREMENTAL HOURS. See detailed explanation of options on page 75. Use the ROTATE FREQUENCY setting to control how often the rotation sequence is changed. FORCE LEAD ROTATE – If set to YES, then when the frequency timer expires and the new order is calculated, this forces the new boiler order to take effect while a heat demand is currently active.
MAINTENANCE WIZARD SCREEN	<ul style="list-style-type: none"> Use this screen to enter relevant data about the Contractor (installer) and boiler.
STARTUP SCREEN	<ul style="list-style-type: none"> This screen summarizes what external sensors are on the boiler, how many boilers are on the network, and the ID of the boiler.
BLOWER CALIBRATION	<ul style="list-style-type: none"> After selecting Start Calibration, blower will begin optimizing to the boiler. The top banner will show similarly to the picture at left with the percentage completion with green progress bar

2

Screens shown on this page are typical only. Actual screens depend on control settings chosen.



EXPRESS SETUP Multi-Boilers - Example A

Multiple Boilers with DHW Storage Tank direct-piped to a single boiler

Purpose

- Space heating with multiple zones using system pump or zone circulators.
- Zoning with circulators or zone valves.
- DHW piped directly to a shadow boiler.
- DHW priority — Shadow boiler with locally piped DHW provides DHW priority while network heating is discontinued on that boiler. Remaining non-DHW boiler(s) will continue to service the network system.

Control Setting Notes

- **Table 2, page 20** follows the general setup required to achieve the shown system with priorities.
- Settings can be made using the WIZARD or by following instructions elsewhere in this manual to enter the settings manually.

Figure 12 Piping schematic - typical piping for multiple EVG boilers. Adjust boiler connections as required for three to eight boilers.

NOTICE:

This method does not provided DHW redundancy. DHW can only be supplied when Boiler 2 is operational.

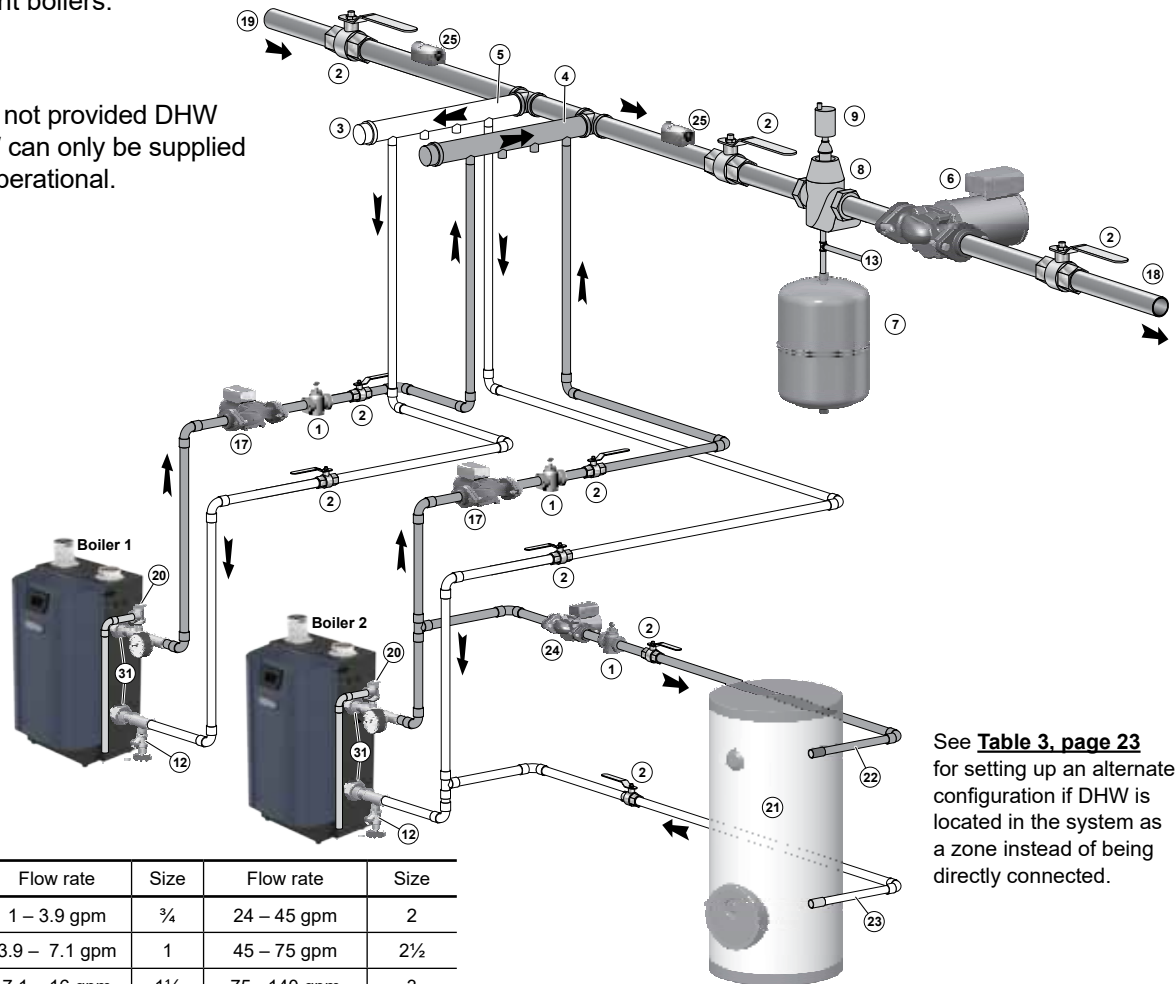

See **Table 3, page 23** for setting up an alternate configuration if DHW is located in the system as a zone instead of being directly connected.

Suggested DHW boiler-side pipe sizing (for max 0.04 feet head loss per foot of total equivalent length, TEL)	Flow rate	Size	Flow rate	Size
	1 – 3.9 gpm	¾	24 – 45 gpm	2
	3.9 – 7.1 gpm	1	45 – 75 gpm	2½
	7.1 – 16 gpm	1¼	75 - 140 gpm	3
	16 – 24 gpm	1½	140 – 290 gpm	4

Legend — Figure 12

1. Flow/check or spring check valve.	13. Cold water supply (per applicable codes).	23. DHW boiler water return, typical.
2. Isolation valves (when used).	17. Boiler circulator — circulates water between boiler and Easy-Fit® Manifolds.	24. DHW boiler-side circulator and flow/check valve.
3. Caps.	18. System supply.	25. Strap system supply and return sensors to lines as shown, at least 6 pipe diameters (but no more than 3 feet) from boiler connection tees. For redundancy, you can install a supply and return sensor connected to each boiler.
4. Easy-Fit® Manifold (supply) — layout and size per page 6 .	19. System return.	31. Unions.
5. Easy-Fit® Manifold (return) — layout and size per page 6 .	20. Boiler relief valve and discharge piping, installed per Evergreen boiler manual.	
6. System circulator. (not used if system is circulator zoned)	21. Indirect-fired storage water heaters (Weil-McLain Aqua Plus Line shown) — Example is shown connected to one boiler of the system. Setup is shown on the next page for this configuration and also for the option of a DHW tank installed as a system zone.	
7. Expansion tank (diaphragm type).	22. DHW boiler water supply, typical.	
8. System air eliminator.		
9. System automatic air vent.		
12. Boiler drain valves.		



EXPRESS SETUP Multi-Boilers - Example A (continued)

Circulators and Piping

⚠ WARNING

Provide an external relay and external power to the boiler circulator if its load rating exceeds 2.2 amps FLA, 3.6 amps locked rotor, or 16.4 amps in rush for boiler circulators, and 2.0 amps FLA for system circulators.

⚠ WARNING

DHW tanks piped using this arrangement need to be sized for the required load, with a DHW pump selected to provide a flow rate through the boiler and tank that is within the allowable flow rate range listed in the table on page 12.

NOTICE

- Follow all sizing guidelines on [page 12](#). Pumps must provide flow rates required.
- Use recognized engineering design practices throughout.

- Piping must be primary/secondary as shown.
- DHW circulator must be selected to handle the pressure drop through the indirect water heater and piping and should provide equivalent or greater flow than boiler circulator.
- For some large indirect water heaters, the required flow rate may require piping the water heater differently.
- The control settings below provide DHW priority. Space heating will be discontinued during a call for DHW.
- Zone circulators and relays supplied by installer. For alternate zone wiring using a zone controller, see manufacturers instructions.
- A boiler circulator is provided with the boiler.
- Follow all instructions in this manual for piping boiler and system.
- See [Figure 13, page 22](#) for setting up an alternate configuration if DHW is located in the system as a zone instead of being directly connected.

Suggested DHW boiler-side pipe sizing (for max 0.04 feet head loss per foot of total equivalent length, TEL)	Flow rate	Size	Flow rate	Size
	1 – 3.9 gpm	¾	24 – 45 gpm	2
	3.9 – 7.1 gpm	1	45 – 75 gpm	2½
	7.1 – 16 gpm	1¼	75 – 140 gpm	3
	16 – 24 gpm	1½	140 – 290 gpm	4

Table 2 Typical Application A multiple boiler system setup requirements. Parameters not listed below can be left at factory default settings, unless special needs indicate different settings.

Boiler Wiring and Control Settings – DHW is Directly Connected (Refer to Figure 14, page 26)						
Boiler ID	TT input	Wired from:	Input Assignment	Aux Option	Output	Wired to: **
1 Master	1	Zone 1 Tstat	Priority 2 - Network 1	N/A	1	Zone 1 Circ/Valve
	2	Zone 2 Tstat	Priority 2 - Network 1	N/A	2	Zone 2 Circ/Valve
	3	No Wire	Aux Pump/Output *	Any TT Input by Priority Settings	3	System Circ Relay * (Item 6)
	4	Zone 3 Tstat	Priority 2 - Network 1	N/A		Zone 3 Circ/Valve
2 Shadow	1	DHW Aquastat	Priority 1 - Local 1	N/A	1	DHW Circ. (Item 24)
	2	Zone 4 Tstat	Priority 2 - Network 1	N/A	2	Zone 4 Circ/Valve
	3	Zone 5 Tstat	Priority 2 - Network 1	N/A	3	Zone 5 Circ/Valve
	4	Zone 6 Tstat	Priority 2 - Network 1	N/A	4	Zone 6 Circ/Valve

* System circulator will not be used if system is circulator zoned. The Aux Pump/Output would not be required for the system pump.

** Outputs are 120 VAC maximum 2.0 amps. Use relay for other voltages or higher amperages.

Priority Settings					
Priority #	Setting	Value	Priority #	Setting	Value
Priority 1 – Local 1 (Boiler 2 only)	System Type	DHW	Priority 2 – Network 1 (Boiler 1 only)	System Type	Select heating system type
	Run 120V Boiler Pump	YES (Note 1)		Run 120V Boiler Pump	YES (Note 1)
	Run Aux Output	NO		Run Aux Output	YES

Note 1: These values cannot be changed.



EXPRESS SETUP Multi-Boilers - Example A (continued)

Field Wiring

Master Boiler – Field Wiring

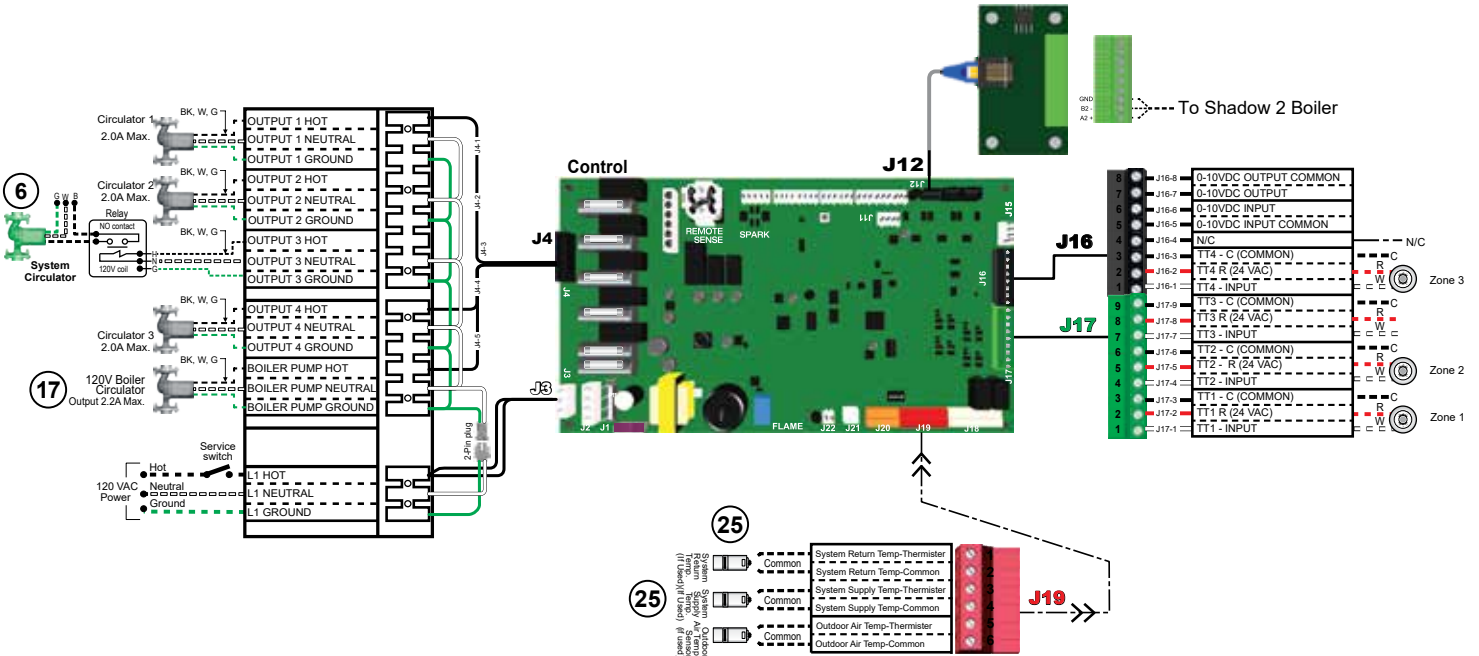

2

Shadow 2 Boiler – Field Wiring

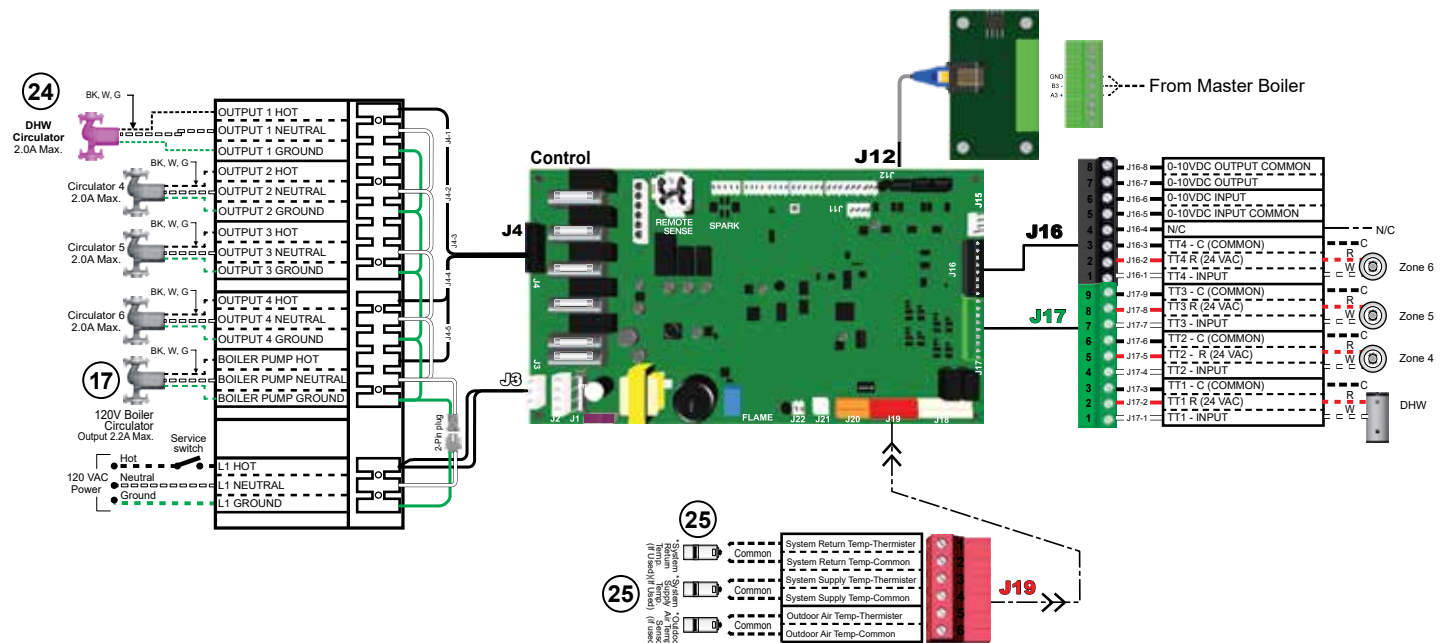

* For redundancy only (not needed)



EXPRESS SETUP Multi-Boilers - Example B

Multiple Boilers with DHW Storage Tank(s) piped in system

Purpose

- Space heating with multiple zones using system pump or zone circulators.
- DHW connected to primary with a secondary connection. Multiple DHW tanks are zoned with circulators.
- DHW priority — space heating is discontinued during call for heat from water heater(s).

Control Setting Notes

- **Table 3, page 23** for required and optional settings.
- The table follows the general setup required to achieve the shown systems with shown priorities.
- Settings can be made using the WIZARD or by following instructions elsewhere in this manual to enter the settings manually.

Figure 13 Piping schematic - typical piping for Multiple EVG boilers. Adjust boiler connections as required for three to eight boilers.

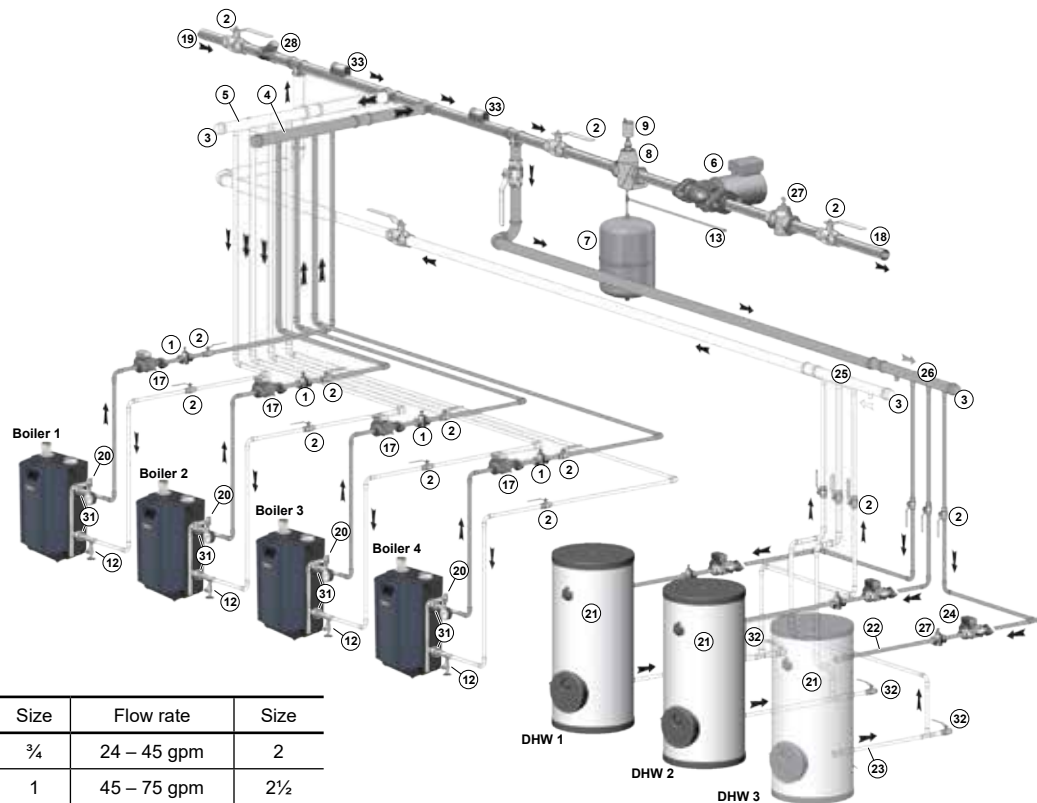

Suggested DHW boiler-side pipe sizing (for max 0.04 feet head loss per foot of total equivalent length, TEL)	Flow rate	Size	Flow rate	Size
	1 – 3.9 gpm	¾	24 – 45 gpm	2
	3.9 – 7.1 gpm	1	45 – 75 gpm	2½
	7.1 – 16 gpm	1¼	75 – 140 gpm	3
	16 – 24 gpm	1½	140 – 290 gpm	4

Legend — Figure 13

1. Flow/check or spring check valve.	21. Indirect-fired storage water heaters (Weil-McLain Aqua Plus Line shown) — Example is shown with each water heater having its own circulator. Alternate: reverse-return boiler-side piping using a single circulator.
2. Isolation valves (when used).	22. DHW boiler water supply, typical.
3. Caps.	23. DHW boiler water return, typical.
4. Easy-Fit® Manifold (supply) — layout and size per page 6 .	24. DHW boiler-side circulators.
5. Easy-Fit® Manifold (return) — layout and size per page 6 .	25. DHW boiler-side supply Easy-Fit® Manifold.
6. System circulator (not used if system is circulator zoned).	26. DHW boiler-side return Easy-Fit® Manifold.
7. Expansion tank (diaphragm type).	27. Flow/check or spring check valves (to prevent induced or gravity flow in heating system or DHW piping).
8. System air eliminator.	28. Check valve.
9. System automatic air vent.	29. See water heater manual for DHW piping — The boiler-side piping in this example uses a separate circulator for each DHW tank.
12. Boiler drain valve	31. Unions.
13. Cold water supply (per applicable codes).	32. Drain valves for DHW boiler water piping.
17. Boiler circulator — circulates water between boiler and Easy-Fit® Manifolds.	33. Strap system supply and return sensors to lines as shown, at least 6 pipe diameters (but no more than 3 feet) from boiler connection tees. For redundancy, you can install multiple sensors, each connected to a different boiler.
18. System supply.	
19. System return.	
20. Boiler relief valve and discharge piping, installed per Evergreen boiler manual.	

NOTICE

This piping is suggested only. The layout above can be controlled with the boiler control's multi-boiler function, DHW priority or by an external control that provides multiple boiler heating and DHW priorities. This will provide domestic priority by disabling the heating system circulator any time there is a DHW call for heat. The boiler circulators, item 17, must operate on any call for heat, whether heating system or DHW. Offset the DHW boiler-side supply and return manifolds as shown so the total run of pipe and fittings to each of the water heaters is approximately equal.



EXPRESS SETUP Multi-Boilers - Example B (continued)

IMPORTANT

Alternate piping: If the DHW circuit is piped elsewhere in the system, these control settings will work only if the System Pump is activated during DHW calls for heat. To set the control for this, set PRIORITY 2 — NETWORK 1 with RUN AUX PUMP/ OUTPUT set to YES instead of NO.

Circulators and Piping

- Piping must be primary/secondary as shown, with the boiler piped in a secondary loop and the DHW piped in a secondary loop with connections spanning the boiler connections.

WARNING

Provide an external relay and external power to the boiler circulator if its load rating exceeds 2.2 amps FLA, 3.6 amps locked rotor, or 16.4 amps in rush for boiler circulators, and 2.0 amps FLA for system circulators.

- DHW circulators supplied by installer. Size circulators for required flow.
- Control settings below provide DHW priority— space heating is discontinued during call for DHW.
- Zone circulators and relays supplied by installer. For alternate zone wiring, see [pages 60](#) and [page 61](#).
- A boiler circulator is provided with the boiler.
- Follow all instructions in this manual for piping boiler and system.

Table 3 Typical Application B multiple boiler system setup requirements. Parameters not listed below can be left at factory default settings, unless special needs indicate different settings.

Boiler Wiring and Control Settings – DHW is Connected to System (Refer to Figure 13, page 22)						
Boiler ID	TT input	Wired from:	Input Assignment	Aux Option	Output	Wired to: **
1 Master	1	Zone 1 Tstat	Priority 3 - Network 2	N/A	1	Zone 1 Circ/Valve
	2	Zone 2 Tstat	Priority 3 - Network 2	N/A	2	Zone 2 Circ/Valve
	3	No Wire	Aux Pump/Output **	Any TT Input By Its Priority Settings	3	System Circ ** (Item 6)
	4	Zone 3 Tstat	Priority 3 - Network 2	N/A	4	Zone 3 Circ/Valve
2 Shadow	1	Zone 4 Tstat	Priority 3 - Network 2	N/A	1	Zone 4 Circ/Valve
	2	Zone 5 Tstat	Priority 3 - Network 2	N/A	2	Zone 5 Circ/Valve
	3	Zone 6 Tstat	Priority 3 - Network 2	N/A	3	Zone 6 Circ/Valve
	4	Zone 7 Tstat	Priority 3 - Network 2	N/A	4	Zone 7 Circ/Valve
3 Shadow	1	Zone 8 Tstat	Priority 3 - Network 2	N/A	1	Zone 8 Circ/Valve
	2	Zone 9 Tstat	Priority 3 - Network 2	N/A	2	Zone 9 Circ/Valve
	3	Zone 10 Tstat	Priority 3 - Network 2	N/A	3	Zone 10 Circ/Valve
	4	Zone 11 Tstat	Priority 3 - Network 2	N/A	4	Zone 11 Circ/Valve
4 Shadow	1	DHW1 Aquastat	Priority 2 - Network 1	N/A	1	DHW 1 Circ (Item 24)
	2	DHW2 Aquastat	Priority 2 - Network 1	N/A	2	DHW 2 Circ (Item 24)
	3	DHW3 Aquastat	Priority 2 - Network 1	N/A	3	DHW 3 Circ (Item 24)
	4	Zone 12 Tstat	Priority 3 - Network 2	N/A	4	Zone 12 Circ/Valve

* System circulator will not be used if system is circulator zoned. The Aux Pump/Output would not be required for the system pump.

** Outputs are 120 VAC maximum 2.0 amps. Use relay for other voltages or higher amperages.

Priority Settings					
Priority #	Setting	Value	Priority #	Setting	Value
Priority 2 – Network 1	System Type	DHW	Priority 3 – Network 2	System Type	Select heating system type
	Run 120V Boiler Pump	YES (Note 2)		Run 120V Boiler Pump	YES (Note 2)
	Run Aux Output	NO		Run Aux Output	YES
	Min Blrs (Note 1)	Select as needed for quick response	N/A	N/A	N/A

Note 1: Min Blrs setting is accessible in the Priority menus (see [Figure 34, page 80](#)).

Note 2: These values cannot be changed.



EXPRESS SETUP Multi-Boilers - Example B (continued)

Field Wiring

Master Boiler – Field Wiring

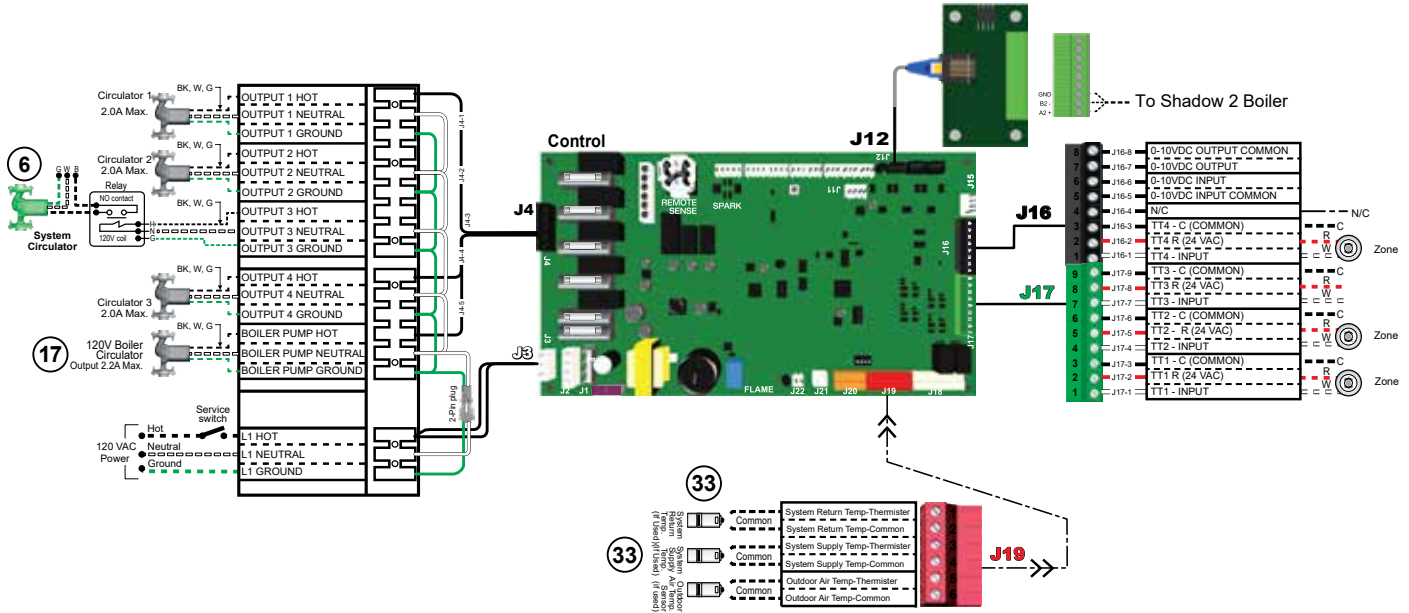

Shadow 2 Boiler – Field Wiring

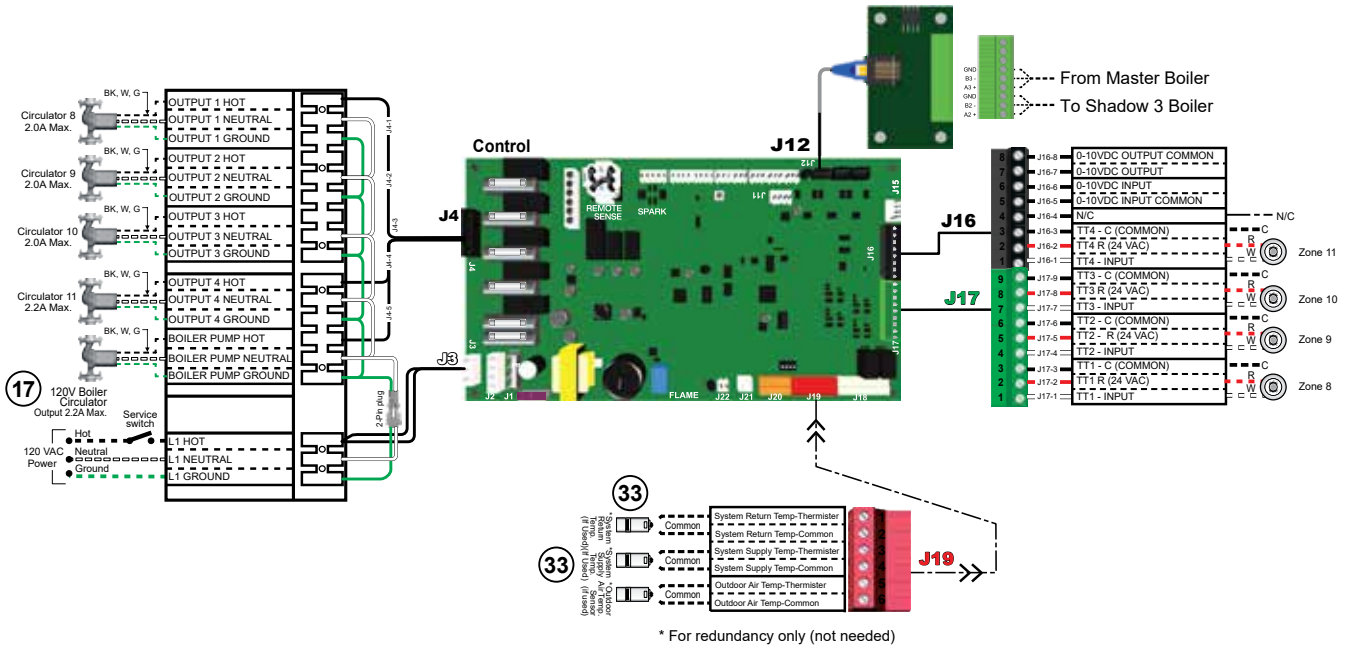

* For redundancy only (not needed)



EXPRESS SETUP Multi-Boilers - Example B (continued)

Field Wiring (continued)

Shadow 3 Boiler – Field Wiring

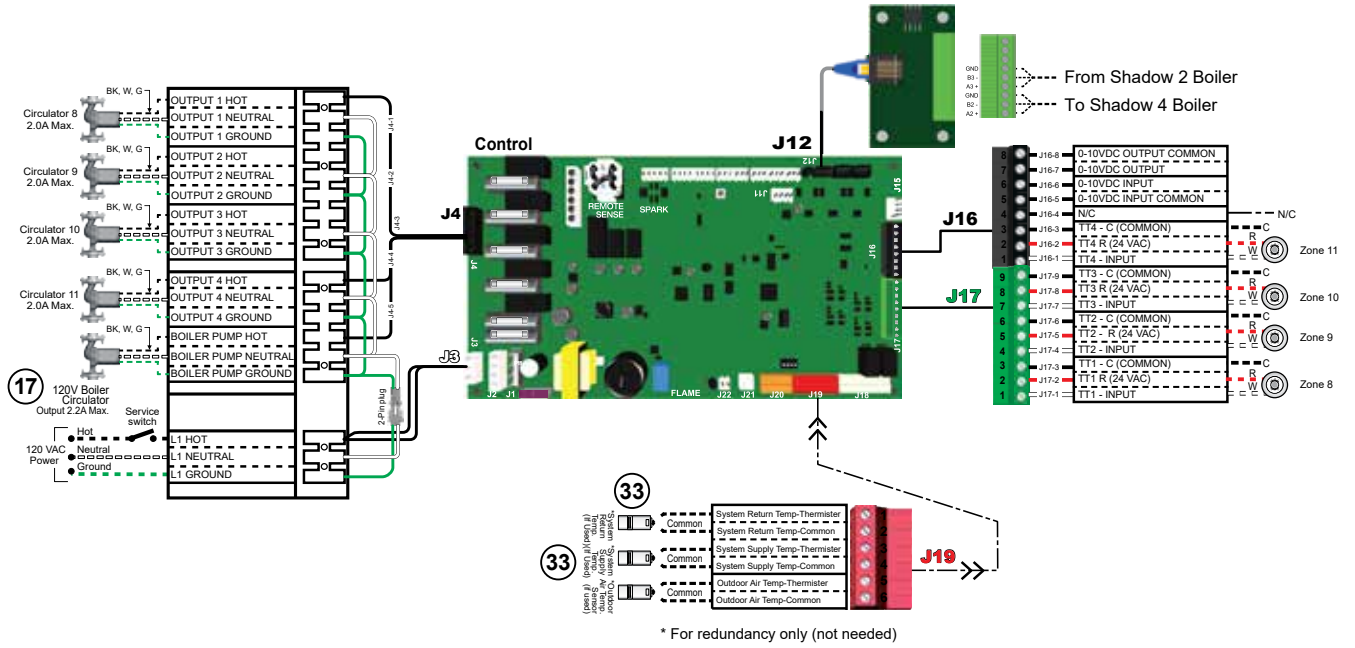

Shadow 4 Boiler – Field Wiring

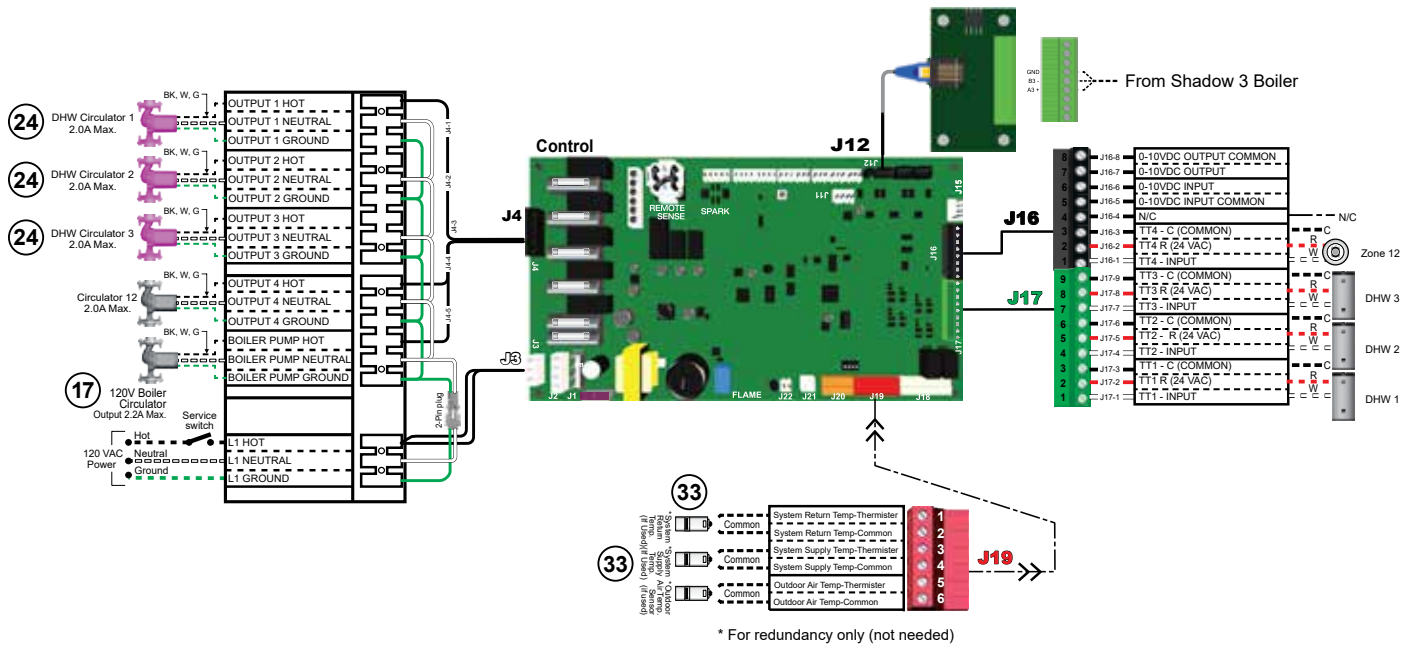



EXPRESS SETUP Multi-Boilers - Example C

Multiple Boilers using isolation Heat Exchanger

Purpose

- Isolation heat exchanger for applications with high system pressure (over 30 PSIG (EVG-110/155) and 80 PSIG (EVG-220-399), such as tall buildings. Typical application shown with shell and tube heat exchanger provided by installer. Boiler maximum allowable pressure is 30 PSIG (EVG-110/155) and 80 PSIG (EVG-220-399). Space heating provided by hot water supply of heat exchanger to terminal units.
- System circulator and shell-side circulator are activated on call for heat by the heating system.
- DHW system not shown.

Figure 14 Piping schematic - typical piping for multiple EVG boilers using Weil-McLain Easy-Fit manifolds. Adjust boiler connections as required for three to eight boilers.

Use isolation heat exchanger for:

1. Large volume systems with high mineral content in water.
2. Systems exposed to untreated quantities of makeup water.
3. Old systems severely contaminated with scale and rust buildup inside piping and heat distribution units.
4. Process applications.
5. Commercial service water applications.
6. High water pressure applications, requiring pressure relief setting in heating system more than 80 PSIG (tall buildings). See notes below.

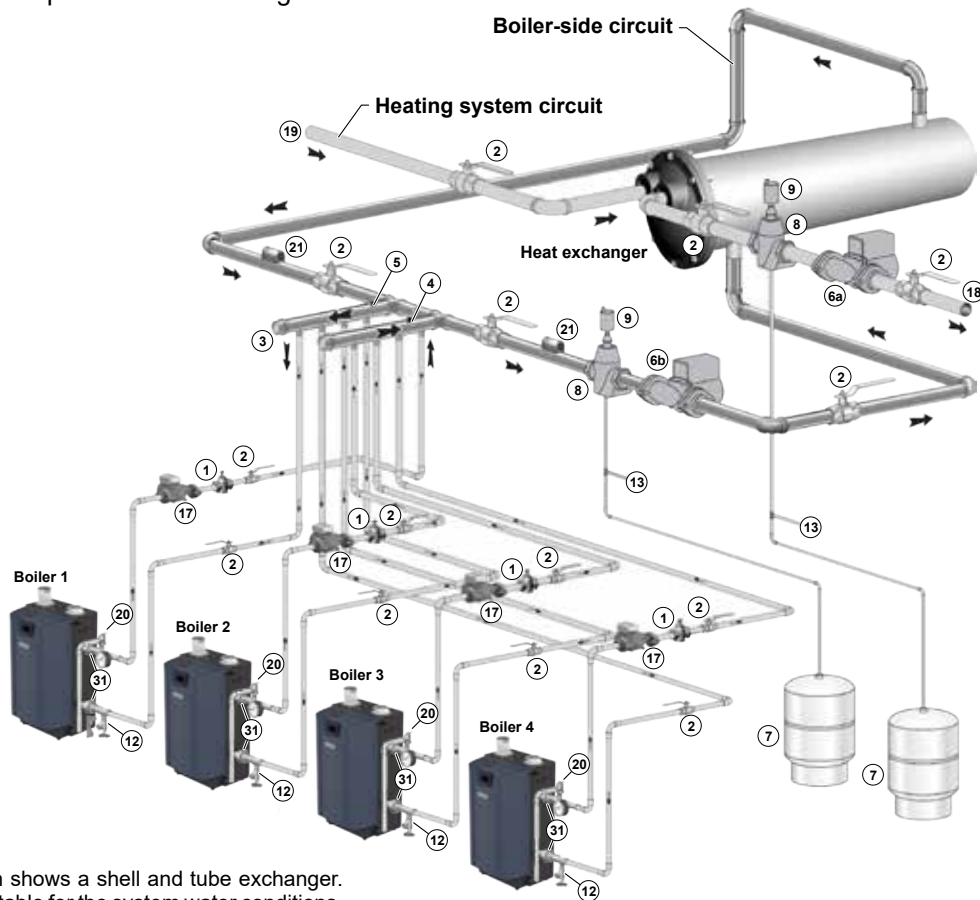

NOTICE

Heat exchanger type — This illustration shows a shell and tube exchanger. Other exchanger types may be used if suitable for the system water conditions.

Legend — Figure 14

<ol style="list-style-type: none"> 1. Flow/check or spring check valve. 2. Isolation valves (when used). 3. Cap. 4. Easy-Fit® Manifold (supply) — layout and size per page 6. 5. Easy-Fit® Manifold (return) — layout and size per page 6. 6a. Heating system circulator (exchanger tube-side). 6b. Heat exchanger shell-side circulator 7. Expansion tanks (diaphragm type). 8. System air eliminator. 9. System automatic air vent. 12. Boiler drain valves. 	<ol style="list-style-type: none"> 13. Cold water supply connections (per applicable codes). 17. Boiler circulator — circulates water between boiler and Easy-Fit® Manifolds. 18. Heating system supply. 19. Heating system return. 20. Boiler relief valve and discharge piping, installed per Evergreen boiler manual. 21. Strap system supply and return sensors to lines as shown, at least 6 pipe diameters (but no more than 3 feet) from boiler connection tees. For redundancy, you can install multiple sensors, each connected to a different boiler. 31. Unions. 	<p>Notes:</p> <ol style="list-style-type: none"> 1. Contact heat exchanger manufacturer for heat exchanger shell-side and tube-side piping and circulator requirements. Tube-side flow and temperatures must meet heating system requirements. 2. Contact heat exchanger manufacturer for sizing heat exchanger. 3. Heat exchanger shell-side circuit requires its own expansion tank as shown. 4. Heating system circuit requires its own expansion tank, as shown, plus its own relief valve set to protect heating system and heat exchanger piping and components. 5. When individual isolation valves are used, individual boiler and level controls may be required.
---	--	--

EXPRESS SETUP Multi-Boilers - Example C (continued)

Use an isolation heat exchanger for:

- Large volume systems with high mineral content in water.
- Systems exposed to untreated quantities of makeup water.
- Old systems severely contaminated with scale and rust buildup inside piping and heat distribution units.
- Process applications.
- Commercial service water applications.
- High water pressure applications, requiring pressure relief setting in heating system more than 160 PSIG (tall buildings).

NOTICE

1. Contact heat exchanger manufacturer for heat exchanger shell-side and tube-side piping and pump requirements. Tube-side flow and temperatures must meet heating system requirements.
2. Contact heat exchanger manufacturer for sizing heat exchanger.
3. Heat exchanger shell-side circuit requires its own expansion tank as shown.
4. Heating system circuit requires its own expansion tank, as shown, plus its own relief valve set to protect heating system and heat exchanger piping and components.

Control Setting Notes

- See Table 4 for required and optional settings.
- The table follows the general setup required to achieve the shown systems with shown priorities.
- Settings can be made using the WIZARD or by following instructions elsewhere in this manual to enter the settings manually.

Circulators and Piping

WARNING

Provide an external relay and external power to the boiler circulator if its load rating exceeds 2.2 amps FLA, 3.6 amps locked rotor, or 16.4 amps in rush for boiler circulators, and 2.0 amps FLA for system circulators..

- Piping must be primary/secondary as shown, with the boiler piped in a secondary loop.
- Size circulators for required flow.
- Zone circulators and relays supplied by installer. For alternate wiring zone see [pages 60](#) and [page 61](#).
- A boiler circulator is provided with the boiler.
- Follow all instructions in this manual for piping boiler and system.



EXPRESS SETUP Multi-Boilers - Example C (continued)

Table 4 Typical Application C multiple boiler system setup requirements. Parameters not listed below can be left at factory default settings, unless special needs indicate different settings.

Boiler Wiring and Control Settings – Using Isolation Exchanger (Refer to Figure 14, page 26)						
Boiler ID	TT input	Wired from:	Input Assignment	Aux Option	Output	Wired to: **
1 Master	1	No Wire	Aux Pump/Output **	Any TT Input By Its Priority Settings **	1	System Circ (Item 6a)
	2	No Wire	Aux Pump/Output	Any TT Input By Its Priority Settings	2	Shell-side Circ (Item 6b)
	3	Zone 1 Tstat	Priority 2 - Network 1	N/A	3	Zone 1 Circ/Valve
	4	Zone 2 Tstat	Priority 2 - Network 1	N/A	4	Zone 2 Circ/Valve
2 Shadow	1	Zone 3 Tstat	Priority 2 - Network 1	N/A	1	Zone 3 Circ/Valve
	2	Zone 4 Tstat	Priority 2 - Network 1	N/A	2	Zone 4 Circ/Valve
	3	Zone 5 Tstat	Priority 2 - Network 1	N/A	3	Zone 5 Circ/Valve
	4	Zone 6 Tstat	Priority 2 - Network 1	N/A	4	Zone 6 Circ/Valve
3 Shadow	1	Zone 7 Tstat	Priority 2 - Network 1	N/A	1	Zone 7 Circ/Valve
	2	Zone 8 Tstat	Priority 2 - Network 1	N/A	2	Zone 8 Circ/Valve
	3	Zone 9 Tstat	Priority 2 - Network 1	N/A	3	Zone 9 Circ/Valve
	4	Zone 10 Tstat	Priority 2 - Network 1	N/A	4	Zone 10 Circ/Valve
4 Shadow	1	Zone 11 Tstat	Priority 2 - Network 1	N/A	1	Zone 11 Circ/Valve
	2	Zone 12 Tstat	Priority 2 - Network 1	N/A	2	Zone 12 Circ/Valve
	3	Zone 13 Tstat	Priority 2 - Network 1	N/A	3	Zone 13 Circ/Valve
	4	Zone 14 Tstat	Priority 2 - Network 1	N/A	4	Zone 14 Circ/Valve

* System circulator will not be used if system is circulator zoned. The Aux Pump/Output would not be required for the system pump. An additional Zone Circ could be used here instead.

** Outputs are 120 VAC maximum 2.0 amps. Use relay for other voltages or higher amperages.

Priority Settings					
Priority #	Setting	Value	Priority #	Setting	Value
Priority 2 – Network 1	System Type	Select heating system type	Priority 3 – Network 2	System Type	N/A
	Run 120V Boiler Pump	YES (Note 2)		Run 120V Boiler Pump	N/A
	Run Aux Output	NO		Run Aux Output	N/A
	Min Blrs (Note 1)	Select as needed for quick response	N/A	N/A	N/A

Note 1: Min Blrs setting is accessible in the Priority menus (see Figure 34, page 80).

Note 2: These values cannot be changed.



EXPRESS SETUP Multi-Boilers - Example C (continued)

Field Wiring

Master Boiler – Field Wiring

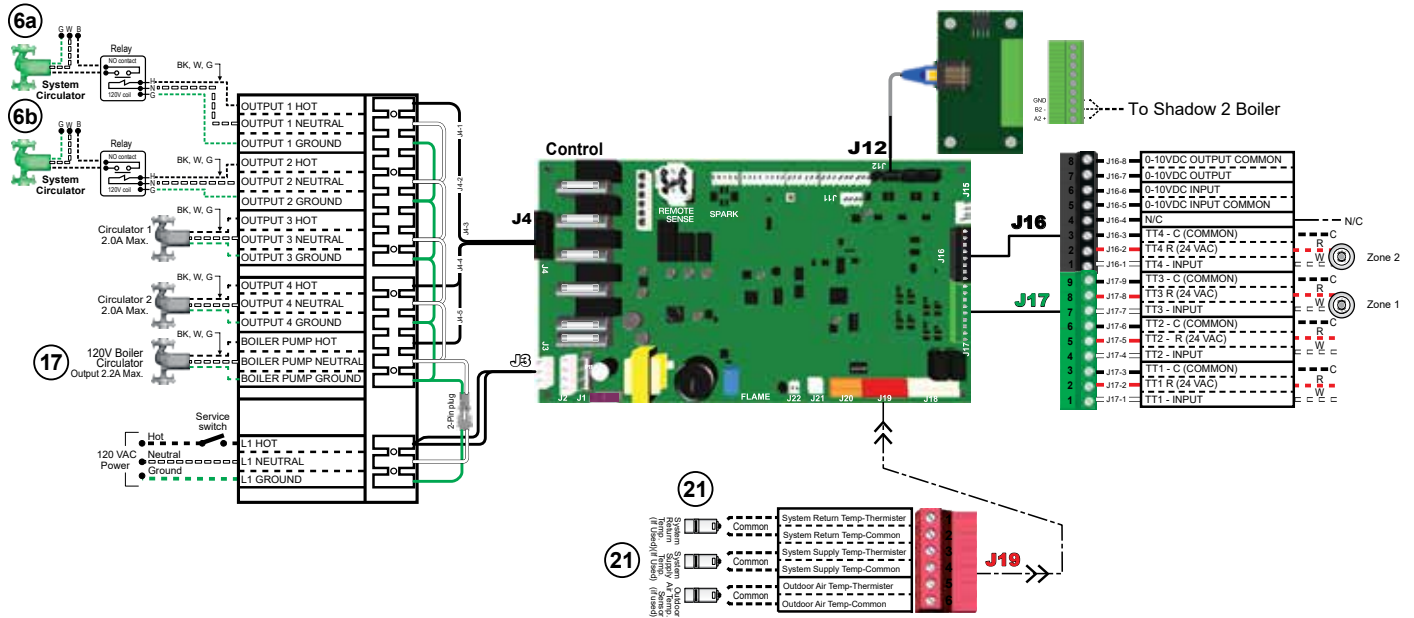

2

Shadow 2 Boiler – Field Wiring

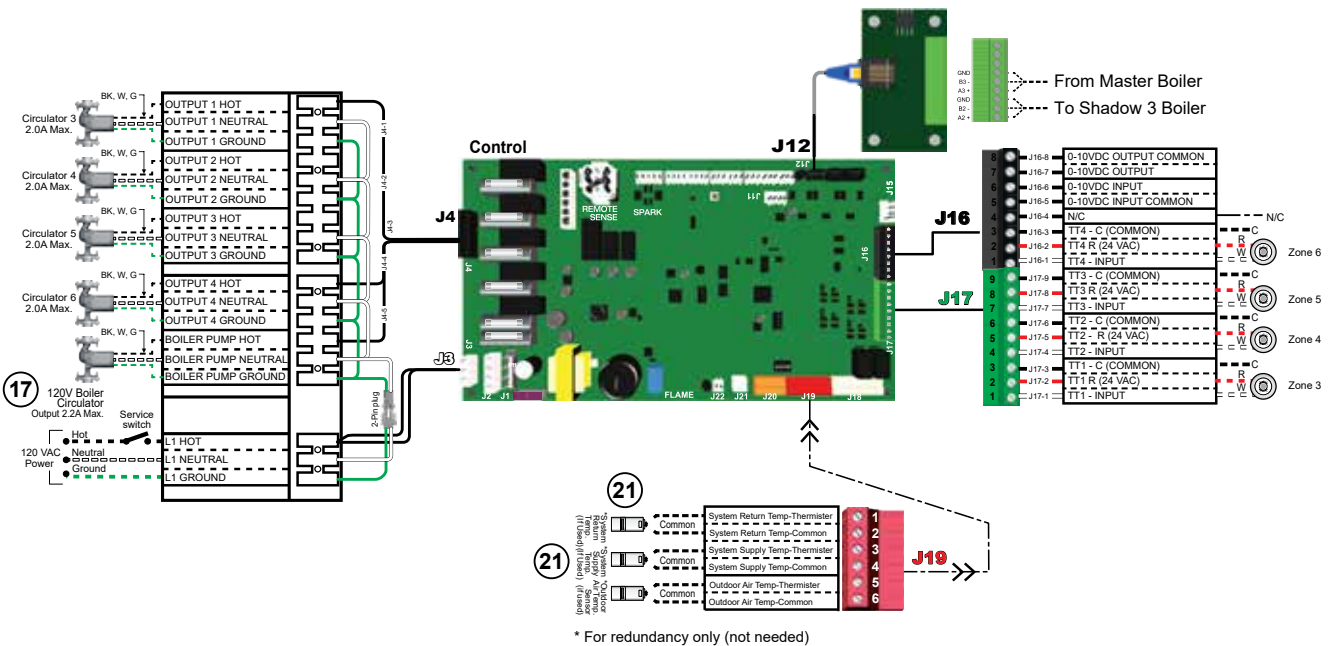



EXPRESS SETUP Multi-Boilers - Example C (continued)

Field Wiring (continued)

Shadow 3 Boiler – Field Wiring

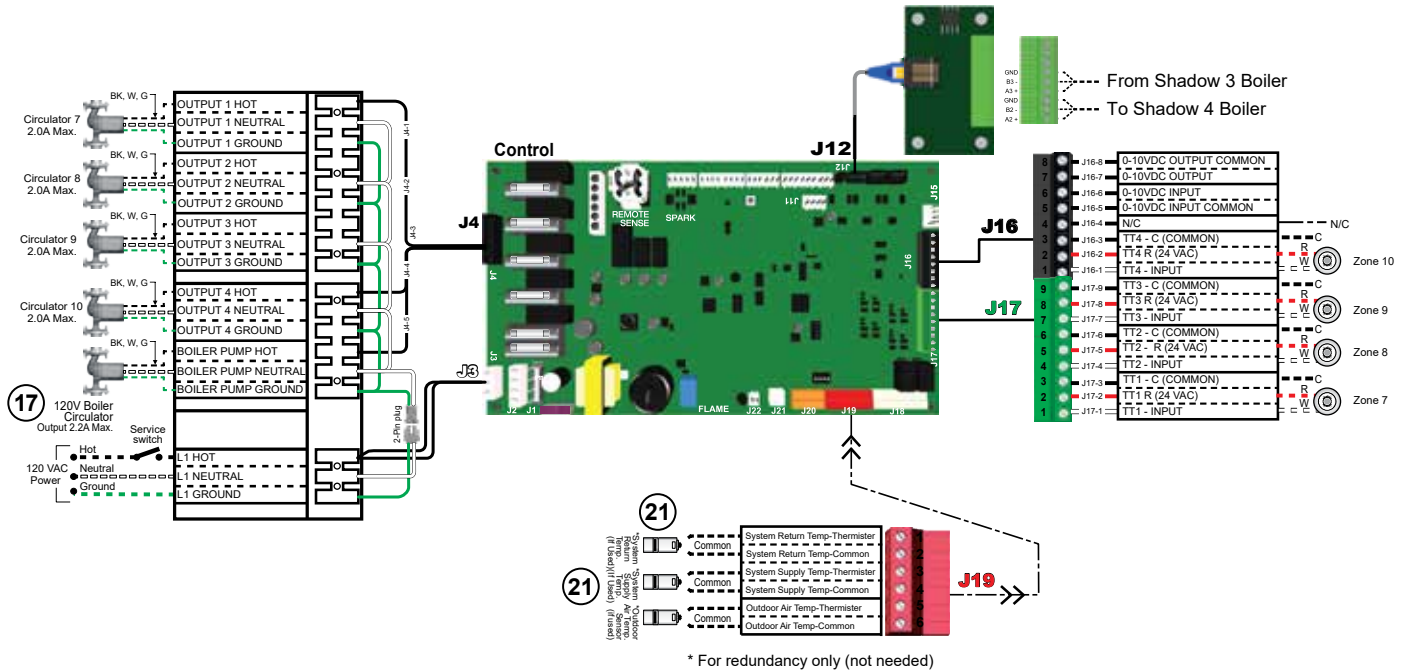

Shadow 4 Boiler – Field Wiring

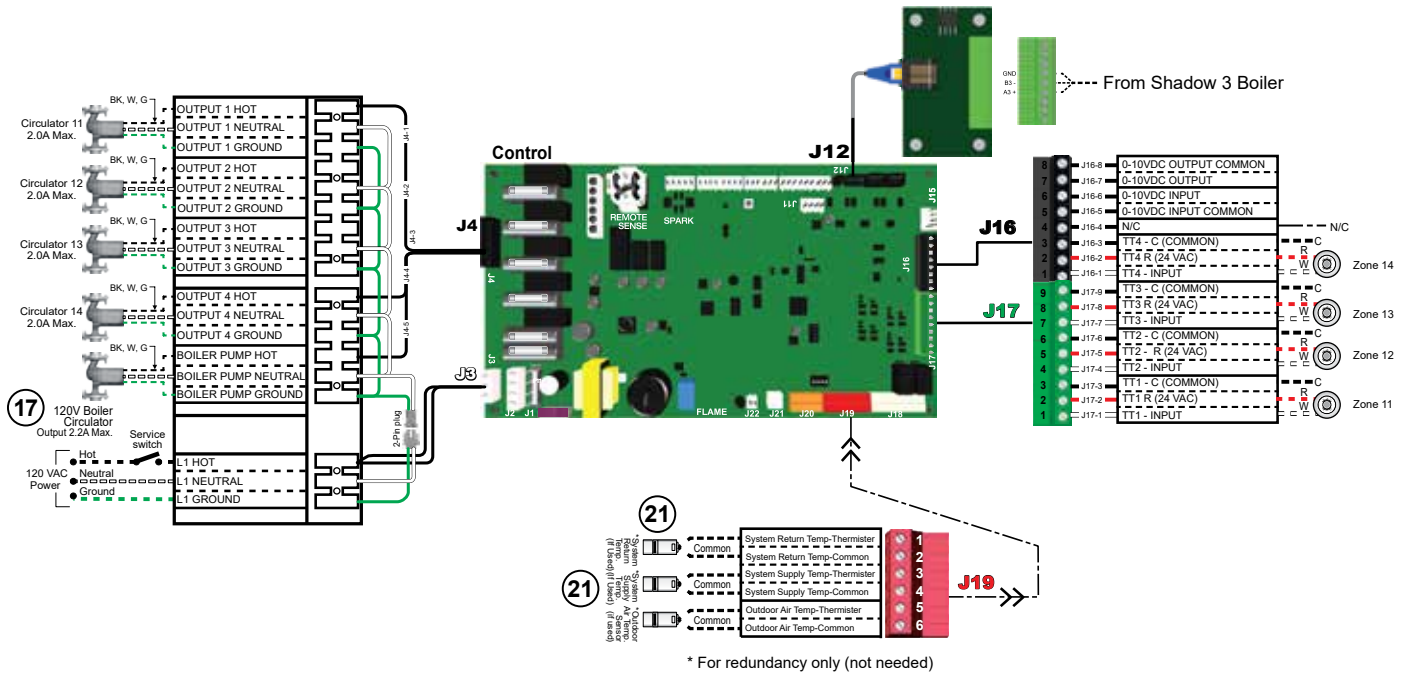



EXPRESS SETUP Multi-Boilers - Example D

Multiple Boilers using isolation heat exchanger with additional High Mass Boiler (Additional Heat Demand)

Purpose

Isolation heat exchanger for applications with high system pressure (over 160 PSIG), such as tall buildings. Typical application shown with shell and tube heat exchanger provided by installer.

- Combine Weil-McLain condensing boilers and large-mass boilers in one system controlled by the control.
- Use condensing boilers during LOW-LOAD periods (spring, fall) and high-mass boilers during HIGH-LOAD periods.
- The Unity 2 control will sequence the high mass boiler when needed.

Figure 15 Piping schematic - typical piping for multiple EVG boilers. Adjust boiler connections as required for three to eight boilers.

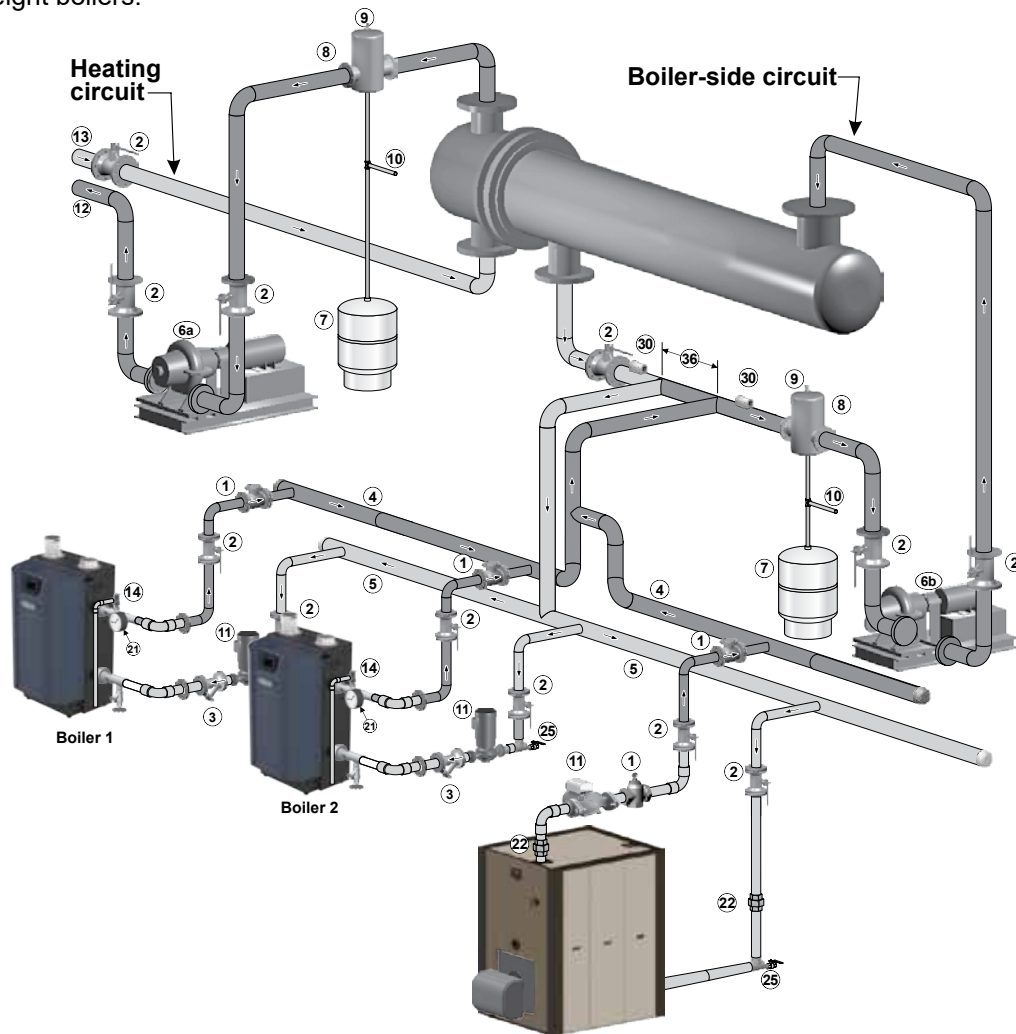

Legend – Figure 15

1. Flow/check or spring check valve.	7. Expansion tank (diaphragm type).	22. 22. Unions (recommended).
2. Isolation valves.	8. System air eliminator.	25. External drain/blowdown valve, when used, 3/4" NPT or larger.
3. Strainer (recommended on each boiler on return line) (Not shown).	9. System automatic air vent.	30. System supply and return immersion sensors, at least 6 pipe diameters (but no more than 3 feet) from boiler connection tees. For redundancy, you can install multiple sensors, each connected to a different boiler.
4. Multiple Boiler Manifold (Supply)	10. Cold water supply.	36. Secondary connection to boiler manifolds — space no greater than 8 pipe diameters apart
5. Multiple Boiler Manifold (Return)	11. Boiler Circulator (each boiler)	
6. Heating system circulator:	12. System supply.	
a. Exchanger tube-side	13. System return.	
b. Shell-side	14. Relief valve and discharge piping, installed per the Evergreen boiler manual.	
	21. Boiler T&P gauge	



EXPRESS SETUP Multi-Boilers - Example D (continued)

Control Setting Notes

- See Table 7 for required and optional settings.
- The table follows the general setup required to achieve the shown systems with shown priorities.

Settings can be made using the WIZARD or by following instructions elsewhere in this manual to enter the settings manually.

NOTICE

1. Contact heat exchanger manufacturer for heat exchanger shell-side and tube-side piping and pump requirements. Tube-side flow and temperatures must meet heating system requirements.
2. Contact heat exchanger manufacturer for sizing heat exchanger.
3. Heat exchanger shell-side circuit requires its own expansion tank as shown.
4. Heating system circuit requires its own expansion tank, as shown, plus its own relief valve set to protect heating system and heat exchanger piping and components.

NOTICE

Use accepted engineering methods to design this system for desired system efficiency and behavior. Ensure that settings for ODT SETPOINT and ACTIVATE CONTACT BELOW SETPOINT are adjusted to the design conditions of the system for proper operation.

Circulators and Piping

⚠ WARNING

Provide an external relay and external power to the boiler circulator if its load rating exceeds 2.2 amps FLA, 3.6 amps locked rotor, or 16.4 amps in rush for boiler circulators, and 2.0 amps FLA for system circulators..

- Piping must be primary/secondary as shown, with the boiler piped in a secondary loop.
- Size circulators for required flow.
- Zone circulators and relays supplied by installer. For alternate wiring zone see [pages 60](#) and [page 61](#).
- A boiler circulator must be supplied by installer.
- Follow all instructions in this manual for piping boiler and system.



EXPRESS SETUP Multi-Boilers - Example D (continued)

Table 5 Typical Application D multiple boiler system setup requirements. Parameters not listed below can be left at factory default settings, unless special needs indicate different settings.

Boiler Wiring and Control Settings (Refer to Figure 16, page 37)						
Boiler ID	TT input	Wired from:	Input Assignment	Aux Option	Output	Wired to: **
1 Master	1	No Wire	Aux Pump/Output *	Any TT Input by its Priority Settings *	1	System Circ (Item 6a)
	2	No Wire	Aux Pump/Output *	Any TT Input by its Priority Settings *	2	Shell-Side Circ (Item 6b)
	3	Zone 1 Tstat	Priority 3 - Network 2	N/A	3	Zone 1 Circ/Valve
	4	Zone 2 Tstat	Priority 3 - Network 2	N/A	4	Zone 2 Circ/Valve
2 Shadow	1	Zone 3 Tstat	Priority 3 - Network 2	N/A	1	Zone 3 Circ/Valve
	2	Zone 4 Tstat	Priority 3 - Network 2	N/A	2	Zone 4 Circ/Valve
	3	Zone 5 Tstat	Priority 3 - Network 2	N/A	3	Zone 5 Circ/Valve
	4	Zone 6 Tstat	Priority 3 - Network 2	N/A	4	Zone 6 Circ/Valve

* System circulator will not be used if system is circulator zoned. Aux Pump/Output would not be required.

** Outputs are 120 VAC maximum 2.2 amps, except Boiler Pump output). Use relay for other voltages or higher amperages.

Priority Settings					
Priority #	Setting	Value	Priority #	Setting	Value
Priority 3 – Network 2	System Type	Select heating system type	N/A	N/A	N/A
	Run 120V Boiler Circulator	YES	N/A	N/A	N/A
	Run Aux Output	YES	N/A	N/A	N/A
	Additional Heat Demand	ODT	N/A	N/A	N/A
	ODT Setpoint	As required for application	N/A	N/A	N/A
	Activate Contact Below Setpoint	1st, 2nd or off based on system requirements	N/A	N/A	N/A
	Activate Contact Above Setpoint	1st, 2nd or off based on system requirements	N/A	N/A	N/A



EXPRESS SETUP Multi-Boilers - Example D (continued)

Field Wiring

Master Boiler – Field Wiring

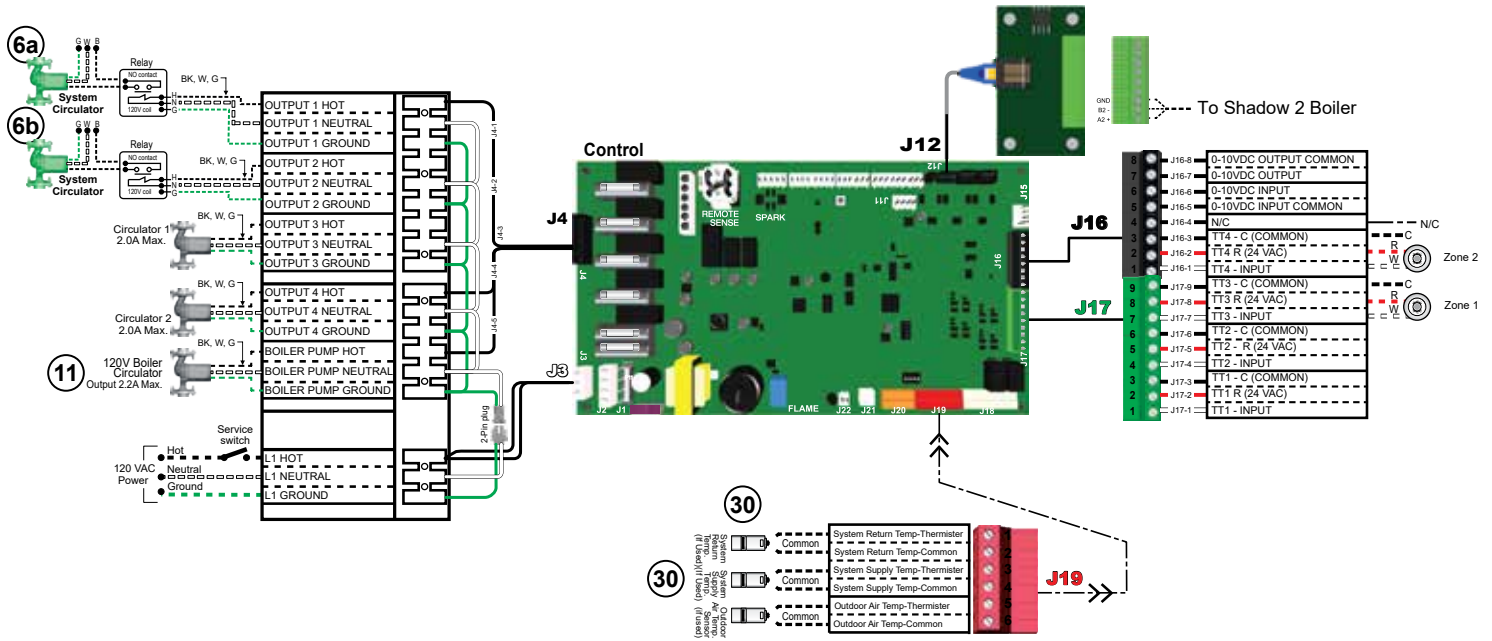

Shadow 2 Boiler – Field Wiring

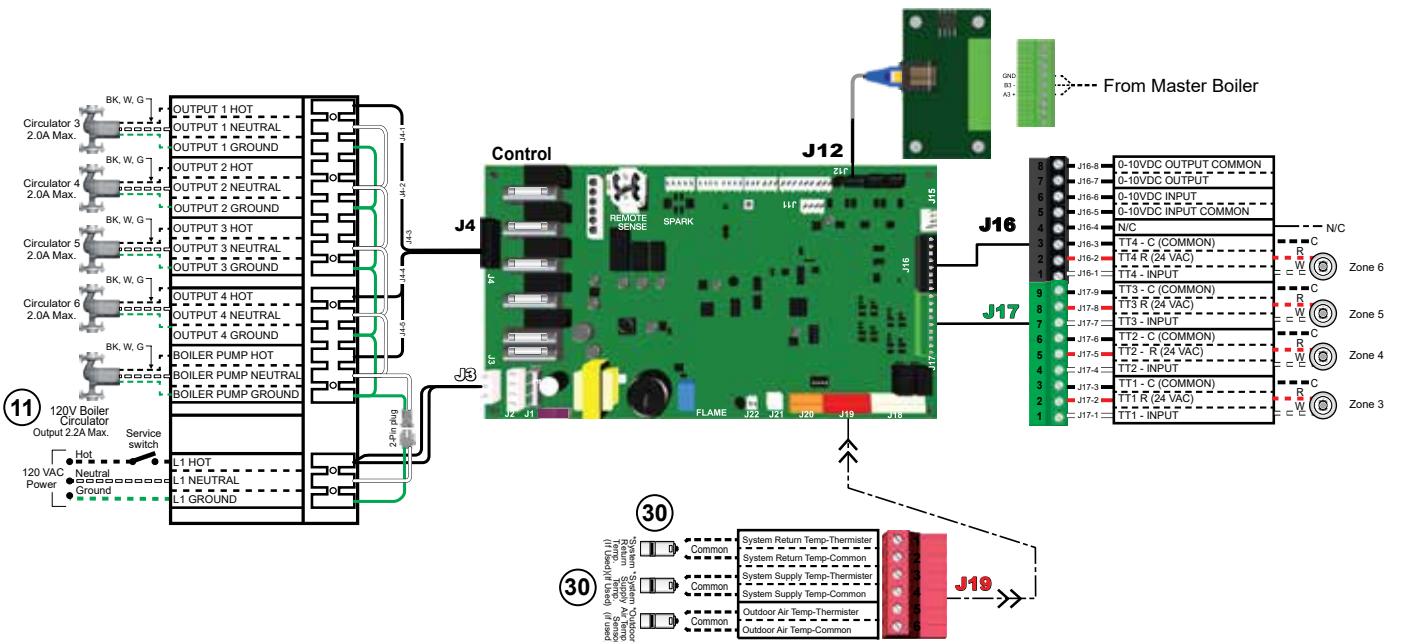

* For redundancy only (not needed)



EXPRESS SETUP Multi-Boilers - Example E

Multiple Boilers using Variable-Primary Piping with DHW Storage Tank direct-piped to a single boiler

Purpose

- Space heating with multiple zones using primary piping with variable speed system circulator.
- DHW piped directly to the Shadow 2 boiler.

- DHW priority – Shadow boiler 2 provides priority to locally piped DHW while network heating is discontinued on that boiler. Boiler 1 will continue to service network system.

Figure 16 Piping schematic - typical piping for multiple EVG boilers. Adjust boiler connections as required for three to eight boilers.

NOTICE This method does not provide DHW redundancy. DHW can only be supplied when Boiler 2 is operational.

NOTICE 38 - It is recommended that a differential pressure by-pass valve be used in case of a motorized valve failure. This will protect/ prevent dead heading the system circulator / pump.

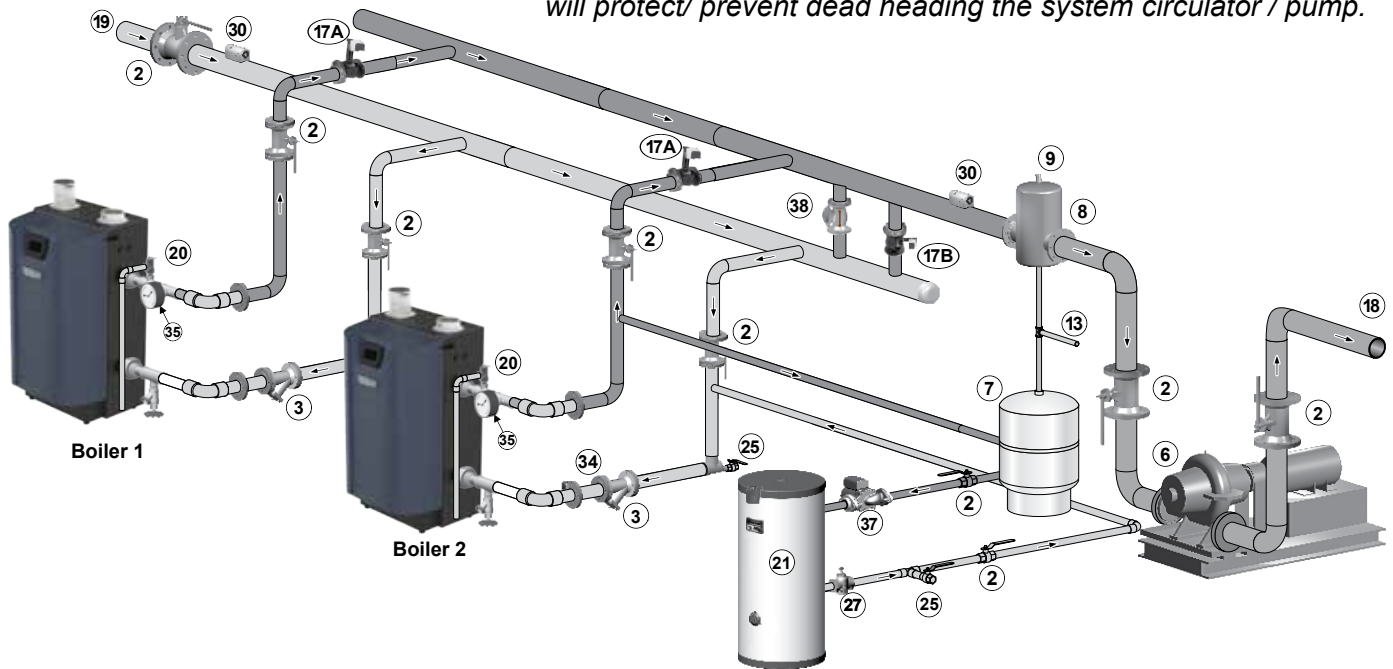

NOTICE 17A - It is recommended to use a 2-way motorized valve with an end switch to indicate when the valve is in the open position. This should be wired into the proof of closure circuit of the Evergreen boiler.

Legend – Figure 16

2. Isolation valves.	17b.By-Pass - 2 Way Motorized Isolation Valve Required if isolation valves are used on individual boilers, or a differential pressure by-pass valve if designed to do so.	25. External drain/blowdown valve, when used, 3/4" NPT or larger.
3. Strainer (recommended on return line to each boiler).	18. System supply.	27. Flow / Check Valve in DHW Piping
6. System pump.	19. System return.	30. System supply and return immersion sensors, at least 6 pipe diameters (but no more than 3 feet) from first and last boiler connection tees.
7. Expansion tank (diaphragm type shown).	20. Boiler relief valve and discharge piping — installed per the Evergreen Boiler Manual.	34. Flow switch is recommended if flow could drop below the minimum flow specified in the table on page 12 .
8. System air eliminator.	21. Indirect-fired storage water heaters (Weil-McLain AQUA PLUS shown). See water heater manual for DHW piping.	35. Boiler T&P gauge
9. System automatic air vent.		37. DHW Circulator
13. Cold water supply (requires items 10, 11 and 12 as shown in Figure 5, page 7).		38. Differential pressure by-pass valve.
17a.Boiler - 2 Way Motorized Isolation Valve (recommended).		



EXPRESS SETUP Multi-Boilers - Example E (continued)

Control Setting Notes

- See **Table 6, page 37** for required and optional settings.
- The table follows the general setup required to achieve the shown systems with shown priorities.
- Settings can be made using the WIZARD or by following instructions elsewhere in this manual to enter the settings manually.
- Variable Primary Circulator is operated by an external controller in the system
- See **Figure 36, page 89** on how to use the control for Primary Valve Control

Circulators and Piping

⚠WARNING

Provide an external relay and external power to the boiler circulator if its load rating exceeds 2.2 amps FLA, 3.6 amps locked rotor, or 16.4 amps in rush for boiler circulators, and 2.0 amps FLA for system circulators..

⚠WARNING

DHW tanks piped using this arrangement need to be sized for the required load, with a DHW pump selected to provide a flow rate through the boiler and tank that is within the allowable flow rate range listed in the table on [page 12](#).

NOTICE

- Follow all sizing guidelines on [page 12](#). Pumps must provide flow rates required.
- Use recognized engineering design practices throughout.

- Size Variable Primary System Circulator for required flow.
- Follow all instructions in this manual for piping boiler and system.
- DHW circulators supplied by installer. Size circulators for required flow.
- DHW can only be supplied when Boiler 2 is operational in the method shown in **Figure 17, page 41**.
- See **Figure 14, page 28** for setting up an alternate configuration if DHW is located in the system as a zone instead of being directly connected.

	Flow rate	Size	Flow rate	Size
Suggested DHW boiler-side pipe sizing (for max 0.04 feet head loss per foot of total equivalent length, TEL)	1 – 3.9 gpm	¾	24 – 45 gpm	2
	3.9 – 7.1 gpm	1	45 – 75 gpm	2½
	7.1 – 16 gpm	1¼	75 - 140 gpm	3
	16 – 24 gpm	1½	140 – 290 gpm	4



EXPRESS SETUP Multi-Boilers - Example E (continued)

Table 6 Typical Application E multiple boiler system setup requirements. Parameters not listed below can be left at factory default settings, unless special needs indicate different settings.

Boiler Wiring and Control Settings – DHW is Directly Connected						
Boiler ID	TT input	Wired from:	Input Assignment	Aux Option / Primary Valve CTRL	Output	Wired to: ***
1 Master	1	Zone 1 Tstat	Priority 2 - Network 1	N/A	1	Zone 1 Circ/Valve
	2	Zone 2 Tstat	Priority 2 - Network 1	N/A	2	Zone 2 Circ/Valve
	3	Zone 3 Tstat	Priority 2 - Network 1	N/A	3	Zone 3 Circ/Valve
	4	No Wire	Primary Valve Control	Iso Valve (NO/NC)	4	Boiler Isolation Valve (Item 17a)
2 Shadow	1	DHW Tstat	Priority 1 - Local 1	N/A	1	DHW Circ.
	2	Zone 4 Tstat	Priority 2 - Network 1	N/A	2	Zone 4 Circ/Valve
	3	No Wire	AuxPump / Output	Bypass Valve (NO/NC)	3	Bypass Valve (NO/NC) (Item 17b) **
	4	No Wire	Primary Valve Control	Iso Valve (NO/NC)	4	Boiler Isolation Valve (Item 17a)

** The 120 VAC output from boiler should be wired in such a way that when energized the valve should close. May require external relay by others.

*** Outputs are 120 VAC maximum 2.2 amps. Use relay for other voltages or higher amperages.

Priority Settings					
Priority #	Setting	Value	Priority #	Setting	Value
Priority 1 – Local 1 (Boiler 2 only)	System Type	DHW	Priority 2 – Network 1 (Boiler 1 only)	System Type	Select heating system type
	Run 120V Boiler Pump (Note 1)	NO		Run 120V Boiler Pump (Note 1)	NO
	Run Aux Output	NO		Run Aux Output	NO

Boiler Wiring and Control Settings – DHW is Located in System as a Zone						
Boiler ID	TT input	Wired from:	Input Assignment	Aux Option / Primary Valve CTRL	Output	Wired to: ***
1 Master	1	Zone 1 Tstat	Priority 3 - Network 2	N/A	1	Zone 1 Circ/Valve
	2	Zone 2 Tstat	Priority 3 - Network 2	N/A	2	Zone 2 Circ/Valve
	3	Zone 3 Tstat	Priority 3 - Network 2	N/A	3	Zone 3 Circ/Valve
	4	No Wire	Primary Valve Control	Iso Valve (NO/NC)	4	Boiler Isolation Valve (Item 17a)
2 Shadow	1	DHW Tstat	Priority 2 - Network 1	N/A	1	DHW Circ/Valve
	2	Zone 4 Tstat	Priority 3 - Network 2	N/A	2	Zone 4 Circ/Valve
	3	No Wire	AuxPump / Output	Bypass Valve (NO/NC)	3	Bypass Valve (NO/NC) (Item 17b) **
	4	No Wire	Primary Valve Control	Iso Valve (NO/NC)	4	Boiler Isolation Valve (Item 17a)

** The 120 VAC output from boiler should be wired in such a way that when energized the valve should close. May require external relay by others.

*** Outputs are 120 VAC maximum 2.2 amps. Use relay for other voltages or higher amperages.

Priority Settings					
Priority #	Setting	Value	Priority #	Setting	Value
Priority 2 – Network 1	System Type	DHW	Priority 3 – Network 2	System Type	Select heating system type
	Run 120V Boiler Pump (Note 1)	NO		Run 120V Boiler Pump (Note 1)	NO
	Run Aux Output	NO		Run Aux Output	NO



EXPRESS SETUP Multi-Boilers - Example E (continued)

Field Wiring

Master Boiler – Field Wiring

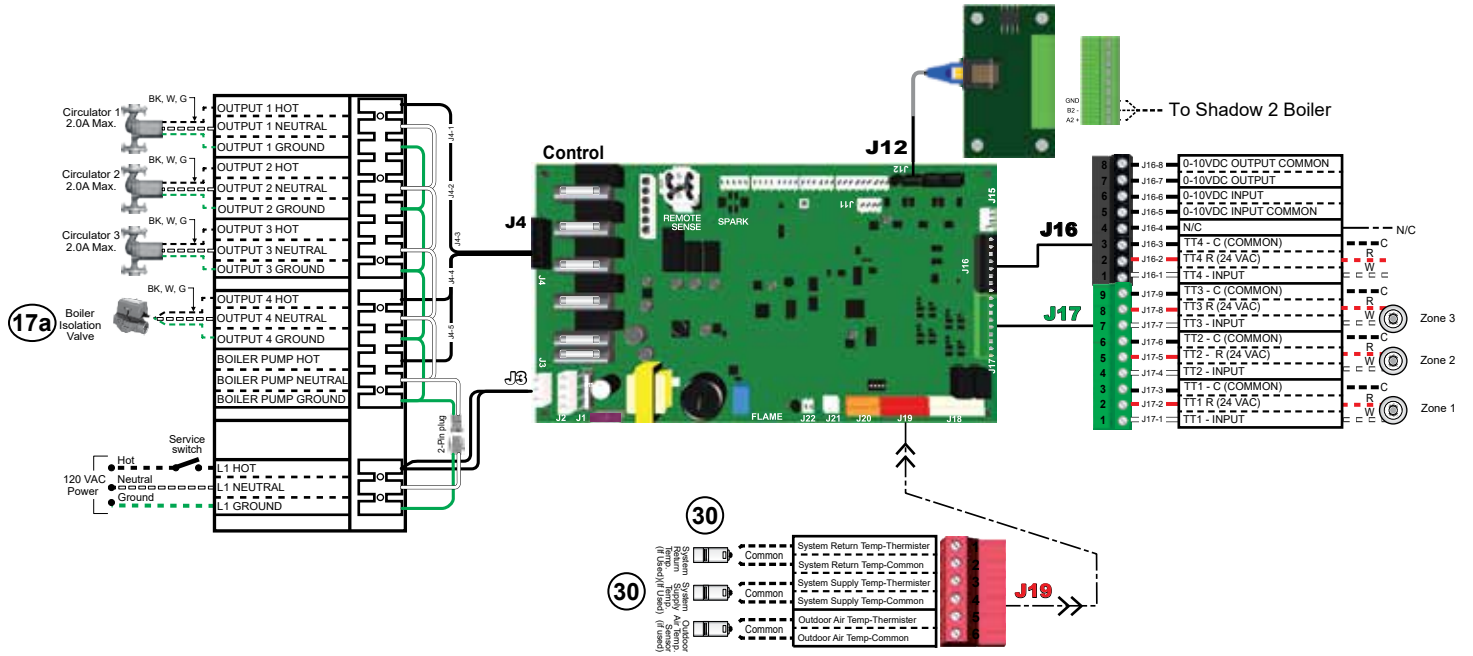

Shadow 2 Boiler – Field Wiring

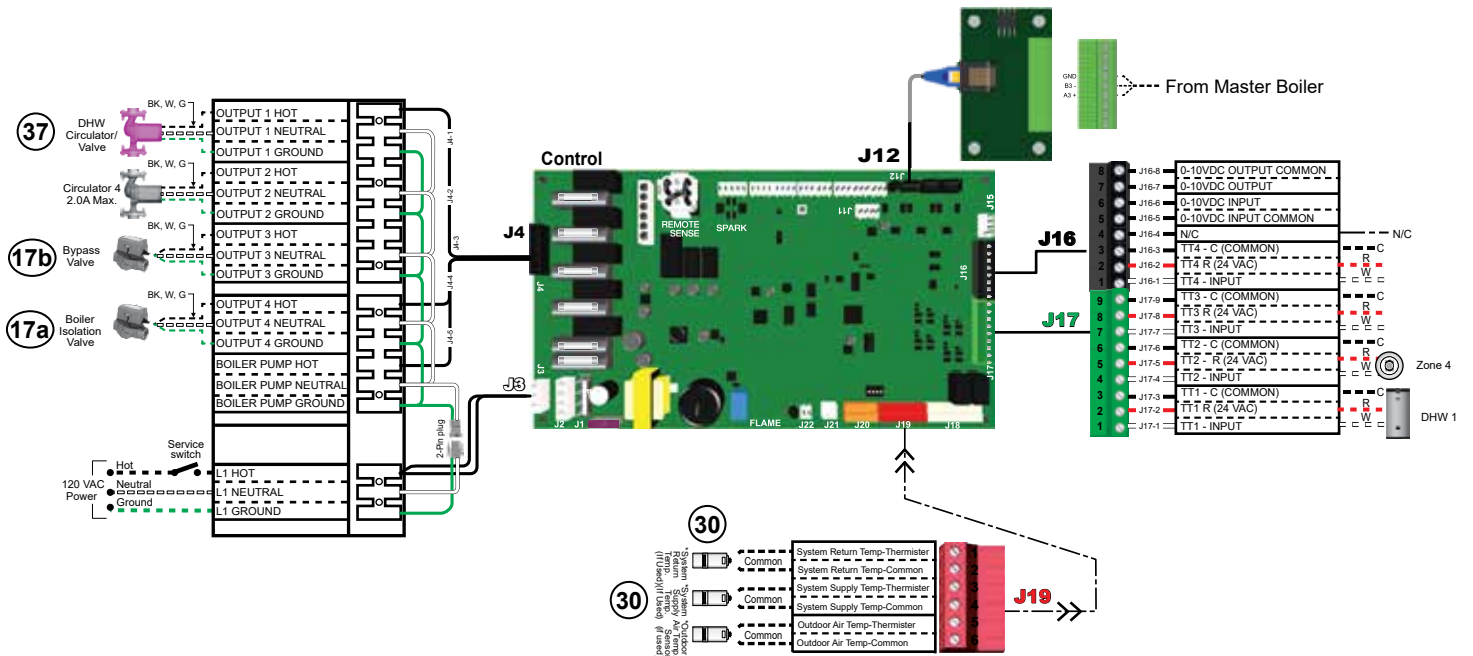

* For redundancy only (not needed)



EXPRESS SETUP Multi-Boilers - Example F

Multiple Boilers using Variable-Primary Piping

Purpose

- Space heating with multiple zones using primary piping with variable speed system circulator.

Figure 17 Piping schematic - typical piping for multiple EVG boilers. Adjust boiler connections as required for three to eight boilers.

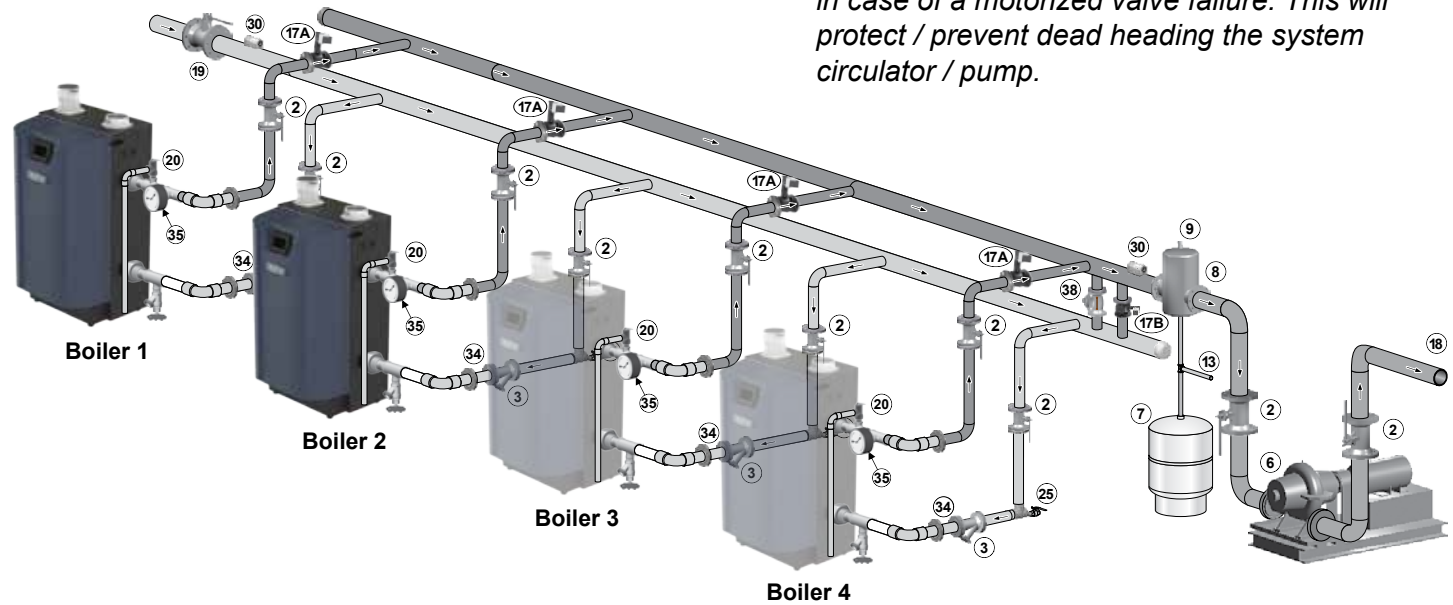

NOTICE 38 – It is recommended that a differential pressure by-pass valve be used in case of a motorized valve failure. This will protect / prevent dead heading the system circulator / pump.

NOTICE 17A – It is recommended to use a 2-way motorized valve with an end switch to indicate when the valve is in the open position. This should be wired into the proof of closure circuit of the Evergreen boiler.

Legend – Figure 17

2. Isolation valves.	17a.Boiler - 2 Way Motorized Isolation Valve (recommended).	25. External drain/blowdown valve, when used, ¾" NPT or larger.
3. Strainer (recommended on return line to each boiler).	17b.By-Pass - 2 Way Motorized Isolation Valve Required if isolation valves are used on individual boilers, or a differential pressure by-pass valve if designed to do so.	30. System supply and return immersion sensors, at least 6 pipe diameters (but no more than 3 feet) from first and last boiler connection tees.
6. System pump.	18. System supply.	34. Flow switch is recommended if flow could drop below the minimum flow specified in the table on page 12 .
7. Expansion tank (diaphragm type shown).	19. System return.	35. Boiler T&P gage
8. System air eliminator.	20. Boiler relief valve and discharge piping — installed per the Evergreen Boiler Manual	38. Differential pressure by-pass valve.
9. System automatic air vent.		
13. Cold water supply (requires items 10, 11 and 12 as shown in Figure 5, page 7).		



EXPRESS SETUP Multi-Boilers - Example F (continued)

Control Setting Notes

- See [page 9](#) for required and optional settings.
- The table follows the general setup required to achieve the shown systems with shown priorities.
- Settings can be made using the WIZARD or by following instructions elsewhere in this manual to enter the settings manually.
- Variable Primary Circulator is operated by an external controller in the system.
- See [Figure 36, page 89](#) on how to use the control for Primary Valve Control.

Circulators and Piping

WARNING

Provide an external relay and external power to the boiler circulator if its load rating exceeds 2.2 amps FLA, 3.6 amps locked rotor, or 16.4 amps in rush for boiler circulators, and 2.0 amps FLA for system circulators..

NOTICE

- Follow all sizing guidelines on [page 12](#). Pumps must provide flow rates required.
- Use recognized engineering design practices throughout.
- Size Variable Primary System Circulator for required flow.
- Follow all instructions in this manual for piping boiler and system.



EXPRESS SETUP Multi-Boilers - Example F (continued)

Table 7 Typical Application F multiple boiler system setup requirements. Parameters not listed below can be left at factory default settings, unless special needs indicate different settings.

Boiler Wiring and Control Settings (Refer to Figure 18, page 45)						
Boiler ID	TT input	Wired from:	Input Assignment	Aux Option / Primary Valve CTR	Output	Wired to: ***
1 Master	1	Zone 1 Tstat	Priority 3 - Network 2	N/A	1	Zone 1 Circ/Valve
	2	Zone 2 Tstat	Priority 3 - Network 2	N/A	2	Zone 2 Circ/Valve
	3	Zone 3 Tstat	Priority 3 - Network 2	N/A	3	Zone 3 Circ/Valve
	4	No Wire	Primary Valve Control	Iso Valve (NO/NC)	4	Boiler Isolation Valve (Item 17a)
2 Shadow	1	Zone 4 Tstat	Priority 3 - Network 2	N/A	1	Zone 4 Circ/Valve
	2	Zone 5 Tstat	Priority 3 - Network 2	N/A	2	Zone 5 Circ/Valve
	3	Zone 6 Tstat	Priority 3 - Network 2	N/A	3	Zone 6 Circ/Valve
	4	No Wire	Primary Valve Control	Iso Valve (NO/NC)	4	Boiler Isolation Valve (Item 17a)
3 Shadow	1	Zone 7 Tstat	Priority 3 - Network 2	N/A	1	Zone 7 Circ/Valve
	2	Zone 8 Tstat	Priority 3 - Network 2	N/A	2	Zone 8 Circ/Valve
	3	No Wire	Aux Pump / Output	Bypass Valve (NO/NC)	3	Bypass Valve (NO/NC) (Item 17b) **
	4	No Wire	Primary Valve Control	Iso Valve (NO/NC)	4	Boiler Isolation Valve (Item 17a)
4 Shadow	1	Zone 9 Tstat	Priority 3 - Network 2	N/A	1	Zone 9 Circ/Valve
	2	Zone 10 Tstat	Priority 3 - Network 2	N/A	2	Zone 10 Circ/Valve
	3	Zone 11 Tstat	Priority 3 - Network 2	N/A	3	Zone 11 Circ/Valve
	4	No Wire	Primary Valve Control	Iso Valve (NO/NC)	4	Boiler Isolation Valve (Item 17a)

** Outputs are 120 VAC maximum 2.2 amps. Use relay for other voltages or higher amperages.

*** The 120 VAC output from boiler should be wired in such a way that when energized the valve should close. May require external relay by others.

Priority Settings					
Priority #	Setting	Value	Priority #	Setting	Value
Priority 3 – Network 2	System Type	Select heating system type	N/A	N/A	N/A
	Run 120V Boiler Pump	NO		N/A	N/A
	Run Aux Output	NO		N/A	N/A
Min Blrs (Note 1)	Select as needed for quick response	N/A		N/A	

Note 1: Min Blrs setting is accessible in the Priority menus (see [Figure 34, page 86](#)); it is not included in the Wizard setup options.



EXPRESS SETUP Multi-Boilers - Example F (continued)

Field Wiring

Master Boiler – Field Wiring

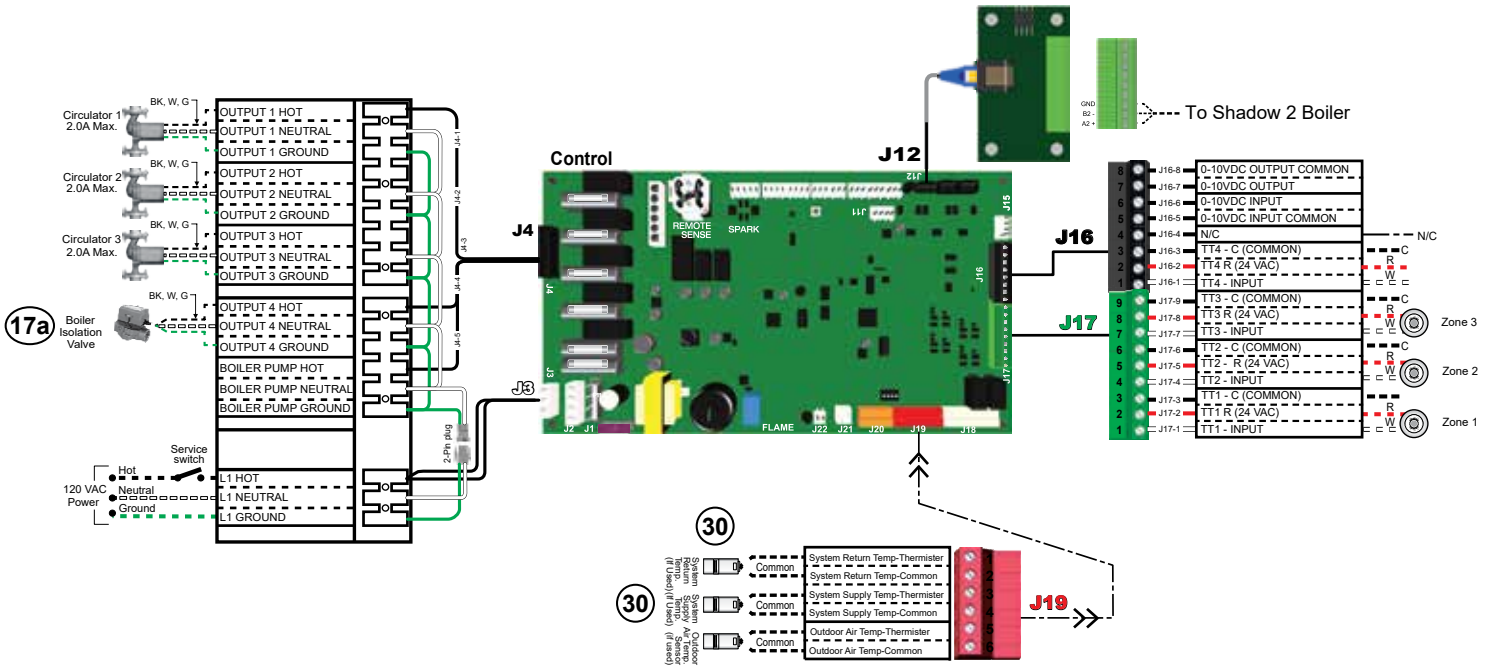

Shadow 2 Boiler – Field Wiring

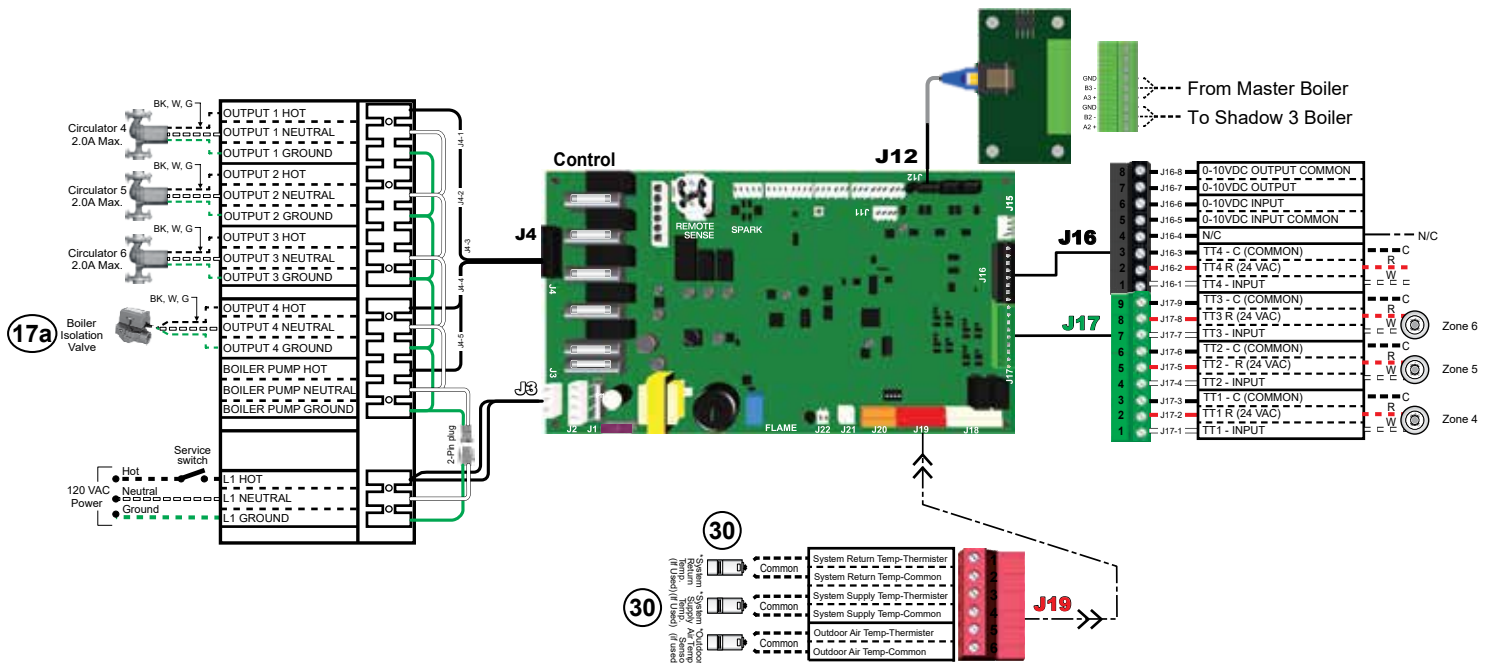

* For redundancy only (not needed)



EXPRESS SETUP Multi-Boilers - Example F (continued)

Field Wiring (continued)

Shadow 3 Boiler – Field Wiring

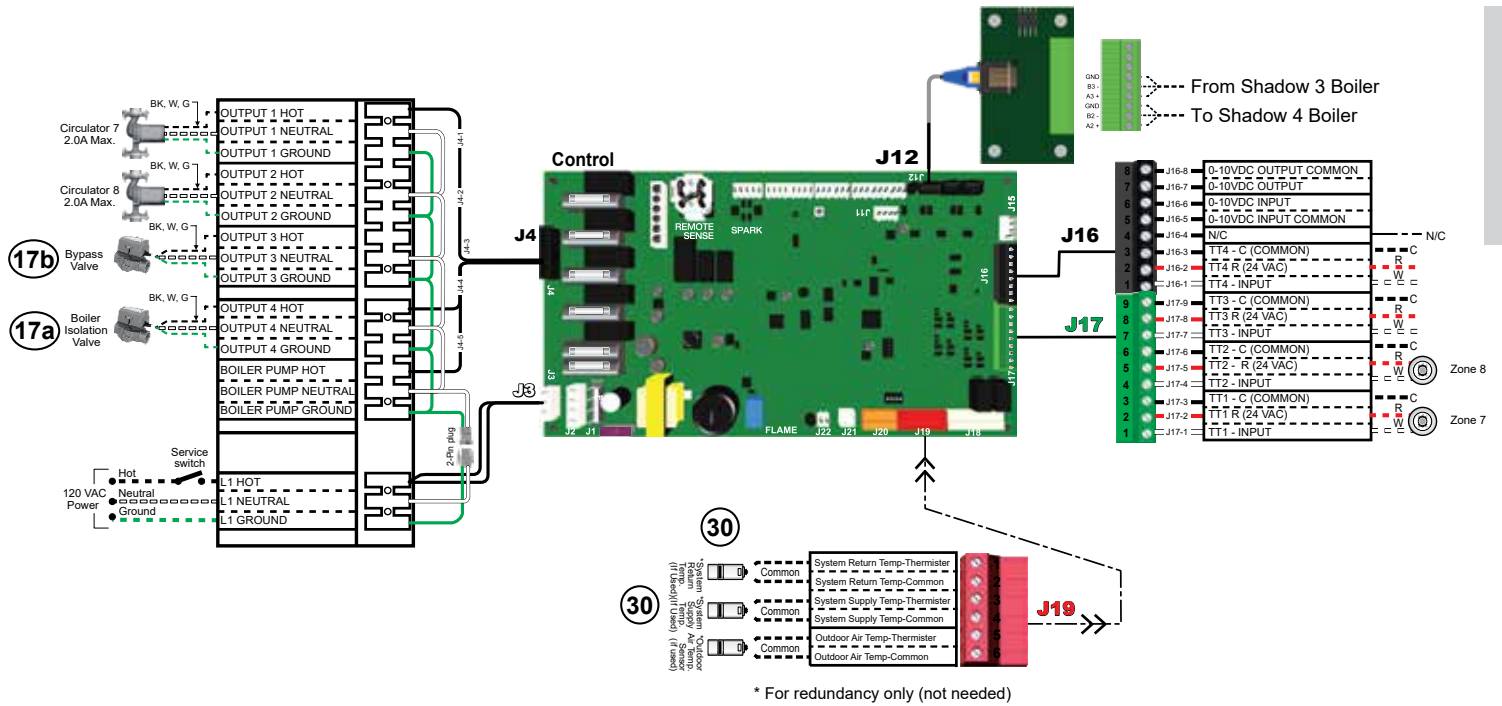

2

Shadow 4 Boiler – Field Wiring

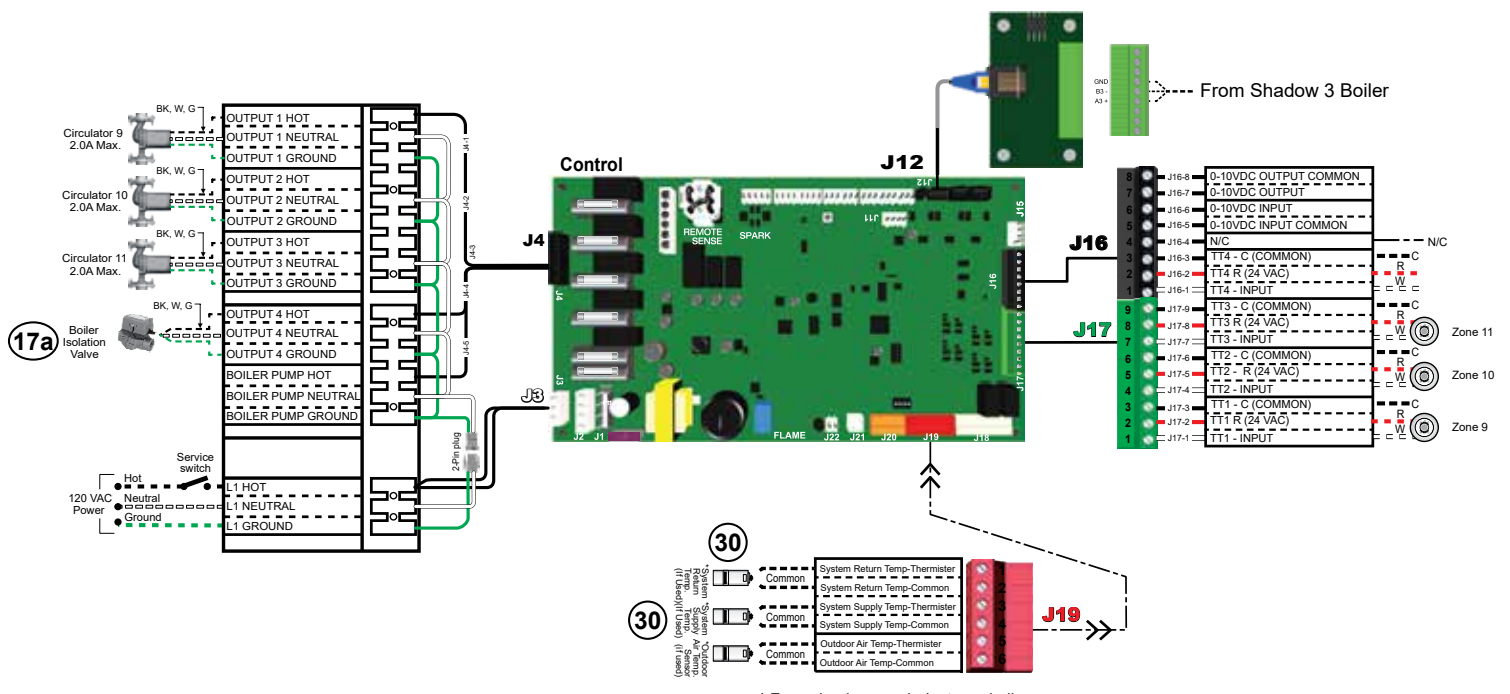



2

This page intentionally left blank



SECTION 3 Electrical

This section is intended to provide wiring and zoning instructions for qualified installers and service contractors.

Section Contents

Electrical – General45
Field Wiring46
Zoning with the Evergreen Pro Control60

Electrical – General

⚠ WARNING

Turn off electrical power supply at the service entrance panel before making any electrical connections. Failure to turn off the electrical power can cause electric shock, which can result in severe personal injury or death.

NOTICE

Do not use 24V from a transformer to power any external devices that are not listed in this manual.

The installation must comply with the National Electrical Code and any other national, state, provincial, or local codes and regulations. In Canada, comply with Canadian Electrical Code, Part 1 – CSA C22.1, and any other local codes.

⚠ WARNING

Wiring errors can cause improper and dangerous operation. Label all wires to ensure proper connection. Never jumper (bypass) any device except for momentary testing. Failure to comply can result in severe personal injury, death, or substantial property damage.

Wiring must be N.E.C. Class 1. If original wiring supplied with the boiler must be replaced, use only type 105°C wire or equivalent. The boiler must be electrically grounded as required by the National Electrical Code – ANSI/NFPA 70, latest edition, or the Canadian Electrical Code, Part 1 – CSA C22.1.

The boiler must be electrically bonded to ground when installed in accordance with the requirements of the authority having jurisdiction. In the absence of such requirements, comply with the requirements in the National Electrical Code – ANSI/NFPA 70, latest edition, or the Canadian Electrical Code, Part 1 – CSA C22.1.

Seal all electrical entrances. Use a sealed strain relief, or a strain relief sealed with duct seal putty or silicone. Sealing the entrances prevents the boiler from drawing air from inside the boiler room; this is particularly important if the boiler is located in the same room as other gas appliances.

⚠ WARNING

All electrical entrances must be sealed. Unsealed entrances can draw air from inside the room, which can result in severe personal injury, death, or substantial property damage.

Power Requirements

- The Evergreen Pro Series 2 boilers are manufactured for 120 VAC, 60 Hz electrical service.
- The total operating amperage of the boiler is dictated by the boiler max draw (7.97A for 220-399, 3.62A for 110 and 3.37A for 155) plus 2.0A per circulator. Maximum total draw is 15.97A for 220-399, 11.62A for 110 and 11.37A for 155. Boiler total draw cannot exceed 80% of the breaker amperage. Size the external disconnect accordingly.
- Before starting the boiler, ensure the proper electrical service is connected to the boiler.
- An external electrical disconnect and overload protection (not supplied with the boiler) **are required**.
- The installed conduit must not block any of the boiler's openings, and it must allow space to remove the boiler door.



Field Wiring (see wiring diagram, [Figure 19, page 56](#))

WARNING

ELECTRICAL SHOCK HAZARD - For your safety, turn off electrical power supply at service entrance panel before making any electrical connections to avoid possible electric shock hazard. Failure to do so can cause severe personal injury or death.

NOTICE

The installation must comply with National Electrical Code and any other national, state, provincial or local codes or regulations. In Canada, CSA C22.1 Canadian Electrical Code Part 1, and any local codes.

Wiring must be N.E.C. Class 1. If original wiring as supplied with boiler must be replaced, use only type 105 °C wire or equivalent. Boiler must be electrically grounded as required by National Electrical Code ANSI/NFPA 70 – latest edition.

Do not use 24V from transformer to power any external devices that are not listed in this manual.

Wire Entrances

EVG 110/155

- Six knockouts are provided in the top of the cabinet for line voltage wiring.
- Three knockouts are provided on the right side of the cabinet for low voltage and communication wiring.
- See [page 47](#) for locations and functions.

EVG 220/299/300/399

- Eight knockouts are provided in the top of the cabinet for line and voltage wiring.
- Three knockouts are provided on the right side of the cabinet for low voltage and communication wiring.
- See [page 47](#) for locations and functions.

WARNING

- **Installer MUST use a strain relief** through jacket knockouts. Failure to do so can cause severe personal injury, death or substantial property damage.
- **Installer MUST SEAL** all electrical entrances using a sealed strain relief or a strain relief sealed with duct seal putty or silicone. Sealing the entrances prevents water from entering the electrical enclosure. Failure to seal entrances could result in severe personal injury, death or substantial property damage.

Wiring Overview

See details on the following pages for the wiring connections outlined below:

Required Wiring Connections

- 120VAC power to boiler; 120VAC power out to boiler circulator; system supply and return temperature sensors; and outdoor temperature sensor (unless exempt as described in this manual).
- LWCO sensor (provided with boiler).

Connections as Needed by Systems

- Thermostat, end switch or other inputs for call for heat.
- System zone circulators, valves, relays, etc.
- System circulator, when required.

Optional Wiring Connections

- External limits; proof-of-closure interlocks (combustion air damper, flow switch, etc.); 0–10VDC for target or modulation control; remote alarm; additional heat demand contact; and communication cables for boiler networking and/or building management system interface (MODBUS). Multiple boiler communication wiring.
1. Wires should be shielded thermostat wires, or equivalent.
 2. Route communication wires through right knockout to communication board on control bracket.
 3. Provide strain relief and seal at cabinet entry.

Wire Routing in the Cabinet

1. Line voltage: (120 Vac in, circulator outputs)
 - a. Line voltage should be wired from the top electrical knockouts going into the control tray.
 - b. Strip end of wire no more than 1/4" to avoid exposing uninsulated wire.
 - c. **(110/155)** It is recommended to install an On/Off service switch in a junction box mounted near the boiler. Installation must meet all National and local electrical codes.
2. Low voltage:
 - a. Mount low voltage wire grommet(s) to desired low voltage knockout(s).
 - b. Thermostat, aquastat, limit devices, system sensors, 0-10 Vdc input/output, and outdoor temperature sensor wire pairs should be routed through the grommets and knockouts.
 - c. Wires should be connected directly into the corresponding terminal block.
 - d. Bundle all wires together with provided wire ties. Loop wire tie with bundled wires through wire tie mount and secure mount to control bracket in bottom right mounting hole.
 - e. After wires and connectors are attached to the control terminal blocks, make sure wires are properly sealed in the cabinet electrical entrances.



Field Wiring (continued)

Wire Routing in the Cabinet

Figure 18 Field wiring overview (see [Figure 18, page 47](#) and [Figure 19, page 56](#) for detailed schematic and ladder wiring diagrams)

EVG 220-399

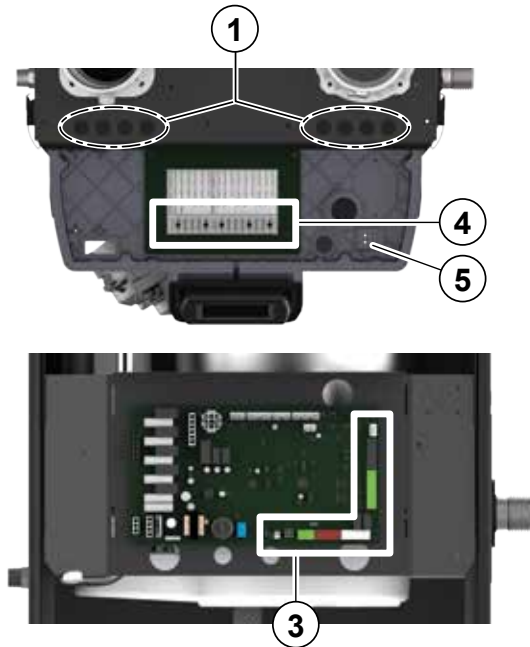

EVG 110/155

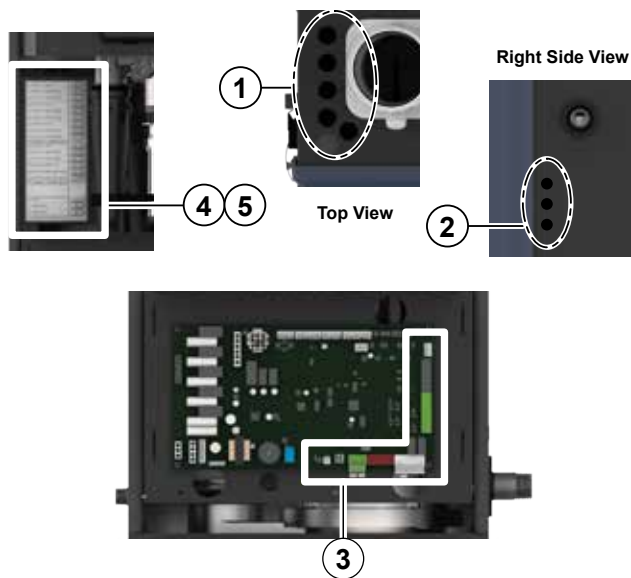

EVG 110/155

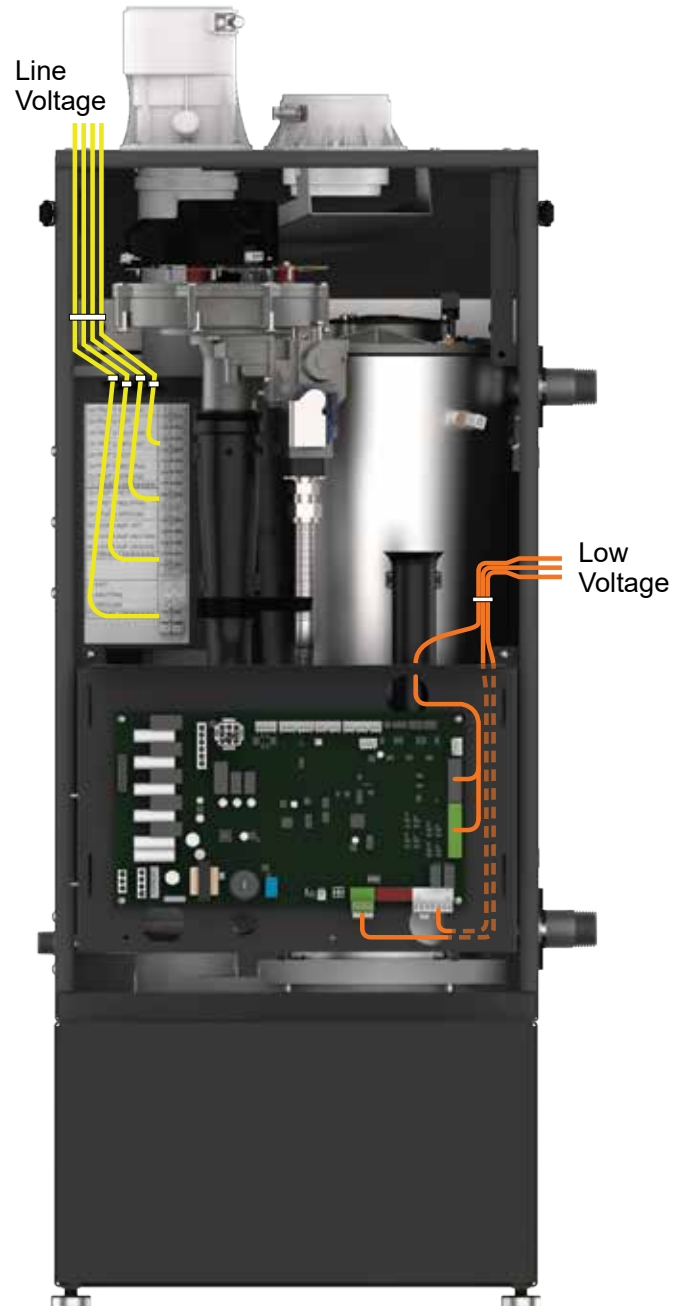

3

1. High voltage Field Wiring knockouts.
2. Low voltage Field Wiring knockouts.
3. Low voltage Field Wiring.
4. 120VAC terminal strip (T1) for boiler power supply (15-amp breaker unless larger capacity is required for outputs connected on terminal strip).
5. 120VAC terminal strip for outputs to circulators or auxiliary devices.



Field Wiring (see wiring diagram, [Figure 19, page 56](#)) (continued)

Terminal Block Wiring

A. 120VAC Power Supply – REQUIRED

Terminal Strip T1

1. Provide and install a properly-sized, fused disconnect or service switch as required by applicable codes. (15-amp for most cases.)
2. For Evergreen 220-399 models, use table at right to determine total load.
For Evergreen 110/155 models, max amp draw is less than 12 amps.
3. Connect properly sized 120VAC power wiring to **Evergreen Pro** boiler line voltage terminal block T1 as shown at right.
4. If possible, provide a surge suppressor in the supply power line. This will reduce the possibilities of control damage due to line surges.
5. Must wire ground to this terminal to provide boiler grounding. Failure to properly ground the boiler can lead to abnormal operation and potential hazards.

Determine total load (220-399 models only)

Boiler & boiler pump (combined load)	5.80 amps
Output 1 (2.0 amps max)	___ amps
Output 2 (2.0 amps max)	___ amps
Output 3 (2.0 amps max)	___ amps
Output 4 (2.0 amps max)	___ amps
Boiler Receptacle 2 amps Max	___ amps
TOTAL	_____

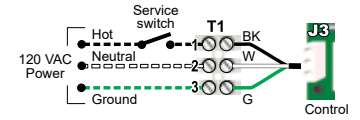

110/155

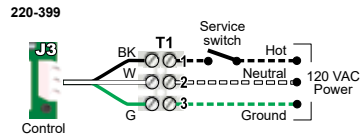

See [Figure 19, page 56](#) for details

B. Receptacle

Located on boiler right side panel

1. Electrical rating is 2.0 amps max at 120VAC.
2. This receptacle can be used to plug in a condensate pump.



Field Wiring (see wiring diagram, **Figure 19, page 56**) (continued)

Terminal Block Wiring (continued)

C. 120VAC Outputs 1, 2, 3, 4 & 5 (Boiler Circulator) – As needed for systems

Terminal Strip T2 & T3

1. Output 1: T3: 7,8,9
2. Output 2: T3: 4,5,6
3. Output 3: T3: 1,2,3
4. Output 4: T2: 4,5,6
5. Boiler Circulator: T2: 1,2,3
6. Maximum output (1-4) load: 2.0A Max, Boiler Circulator 2.2A Max (use relay if circulator load is higher). See WARNING below.
7. These four outputs (Output 1, Output 2, Output 3, and Output 4) can provide 120VAC to the following listed below:
 - A zone circulator.
 - A system circulator.
 - A DHW circulator (used to circulate through an indirect tank).
 - An Auxiliary Item that may be energized during an input call, such as an air damper.
8. When using inputs/outputs for heat/Indirect DHW demands, each input (Input 1, Input 2, Input 3, and Input 4) controls its respective 120VAC output (Output 1, Output 2, Output 3, and Output 4). Outputs are energized only when BOTH conditions below are met:
 - a. The corresponding input indicates a call for heat/ Indirect DHW (i.e. contact closure).
 - b. The PRIORITY assigned to the Input/Output pair is ACTIVE (i.e. the zone may be calling but the pump won't activate unless the boiler is currently running on that system/priority).

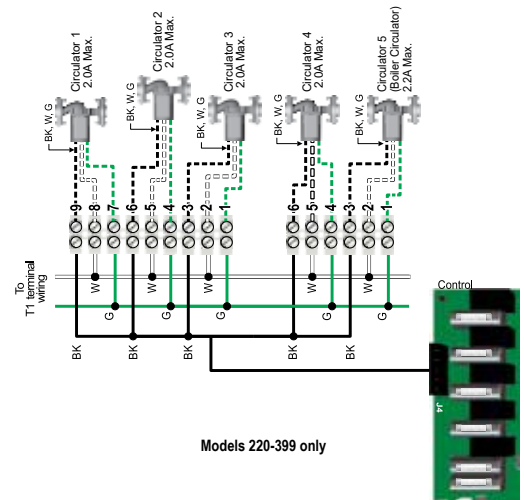
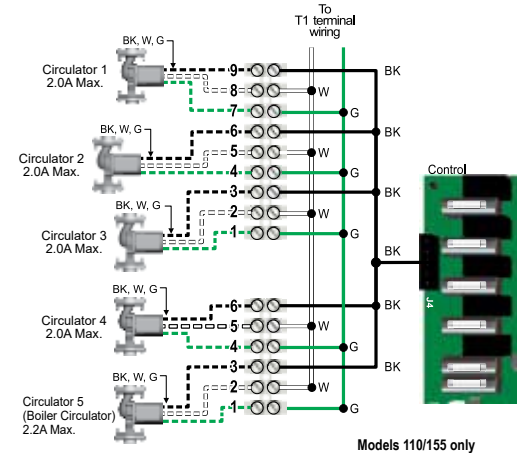

See **Figure 19, page 56** for details.



Output circuits are 120VAC. If an output is to operate a low voltage circuit or must be an isolated contact, use an isolation relay.



CIRCULATOR POWER - The maximum allowable current for each circulator is 2.0 amps for circulators 1-4, and 2.2 for boiler circulator (Circ 5) at 120VAC. For circulators with higher amp ratings, install a circulator relay or starter. Connect only the 120VAC coil to the circulator terminals.



Field Wiring (see wiring diagram, [Figure 19, page 56](#)) (continued)

Terminal Block Wiring (continued)

D. Inputs 1, 2, 3 and 4 (demands) – As needed for systems

Connector J17 (Input 1, 2, &3) & Connector J16 (Input 4, 0–10VDC Input)

1. Input 1 – Connector J17 – 1, 2 & 3 (common)
2. Input 2 – Connector J17 – 4, 5 & 6 (common)
3. Input 3 – Connector J17 – 7, 8 & 9 (common)
4. Input 4 – Connector J16 – 1, 2 & 3 (common)
5. These four (4) inputs on each boiler can indicate a call for heat to the control by means of a dry contact closure (thermostat, aquastat, or switch). (See right and [Figure 19, page 56](#)).
6. The control provides inputs for up to four (4) demands and up to three (3) systems (priorities).
7. **For Priority Indirect DHW Application:**
8. The DHW aquastat can be connected to any one of the four (4) input/output pairs. The selected input should be assigned to PRIORITY 1 during the WIZARD setup or manually in the System Settings menu.
9. The default control setting uses each input (INPUT 1, INPUT 2, INPUT 3 and INPUT 4) to control its respective 120VAC output (OUTPUT 1, OUTPUT 2, OUTPUT 3 and OUTPUT 4).

NOTICE

Use of 0–10VDC input for modulation disables Input 2 T/T input from creating calls for heat. See [page 11](#) for instructions.

An input can be assigned to an AUX PUMP/OUTPUT function to operate a system pump or interlock with a combustion air damper. Inputs assigned for this function cannot be used for heat demand operation. See [page 82](#) for more information on the setup and selection of operating conditions.

WARNING

Thermostats - DO NOT supply 24-volt power to the thermostat circuits (Input 1, Input 2, Input 3 and Input 4 in [Figure 19, page 56](#)) or attempt to supply 24 volts for any other application.

For thermostats that require a continuous 24-volt power source, connect the common wire (“C”) (see [Figure 19, page 56](#)). Do NOT exceed 120mA total amp draw at 24VAC per thermostat.

TT or end switch inputs
(INPUTS 1, 2, 3 and 4)
With External 0-10VDC inputs

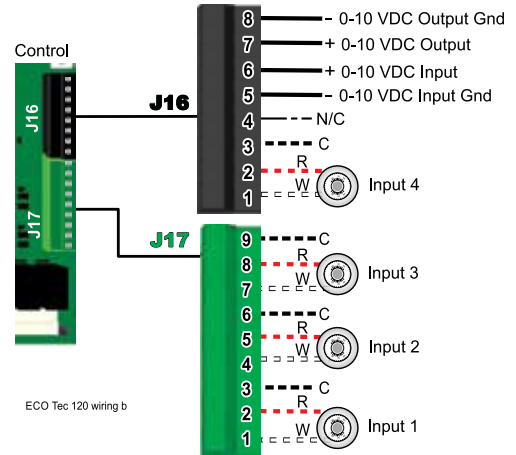

See [Figure 19, page 56](#) for details.

Zone valves - If using 3-wire zone valves, use relays to provide dry contacts to the Control thermostat connections. The zone valve end switches of 3-wire valves carry 24VAC from the valve.

Thermostat anticipator setting - 0.1 amps.

Field Wiring (see wiring diagram, [Figure 19, page 56](#)) (continued)

Terminal Block Wiring (continued)

E. System supply and return temperature sensors – Recommended when using primary secondary piping design. Connector J19

1. It is recommended to use two (2) strap-on temperature sensors (separate kit option). Attach one to the system supply piping and the other to the system return piping. For piping larger than 5 inch diameter or nonmetallic piping, using immersion sensors will provide faster response.
2. Locate the supply sensor at least six pipe diameters, but no further than 3 feet, downstream from the boiler connection to the main to ensure adequate mixing.
3. Return sensor – wire between J19 #1 and #2.
4. Supply sensor – wire between J19 #3 and #4.
5. Thermostat wire can be used to connect these sensors.
6. The Control compares the system return temperature with the system supply temperature.

NOTICE

It is recommended for all primary/secondary heating systems shown in this manual that the System Supply and Return sensors to be installed for proper control function. System may not properly provide desired temperature if sensors are not installed according to these instructions.

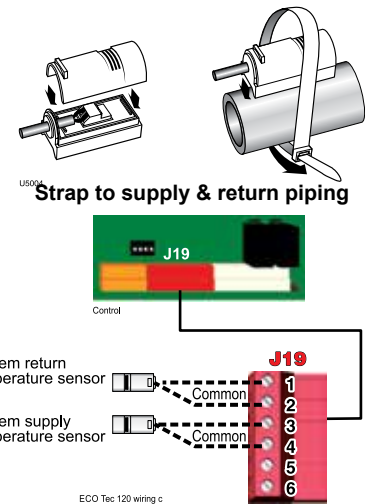

See [Figure 19, page 56](#) for details.

F. Outdoor temperature sensor – REQUIRED unless exempted

Connector J19

1. The control provides programmable options if using an outdoor temperature sensor. This sensor is supplied with the boiler.
2. **The outdoor sensor must be installed unless specifically exempted in the Energy Act statement on page 193 in boiler manual.**
3. Mount the outdoor sensor on an exterior wall, shielded from direct sunlight or flow of heat or cooling from other sources.
4. The wire outlet on the sensor must be oriented DOWN to prevent water entry.
5. Connect the sensor leads to the terminal shown at right and in the wiring diagrams (see [Figure 19, page 56](#)). Thermostat wire can be used to connect the sensor.

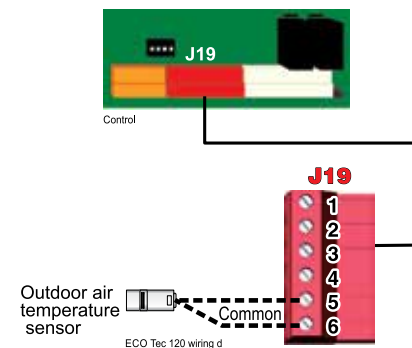

See [Figure 19, page 56](#) for details.

G. External limits – OPTIONAL

To cause MANUAL reset: Connector J20 #1 & #2

The control will require manual reset after circuit is interrupted.

1. Remove factory-installed jumper and connect isolated contacts of external limits across J20 pins 1 and 2 to cause the control to enter manual reset lockout if the limit circuit opens. The limit must close and the control must be manually reset using the procedure given in this manual. See drawing at right and wiring diagram [Figure 19, page 56](#).

NOTICE

The control will lockout when a limit in its manual reset circuit opens (J20 pins 1 & 2). The control activates its alarm terminals and shuts the boiler down. An operator (user or technician) must manually reset the control to restart the boiler.

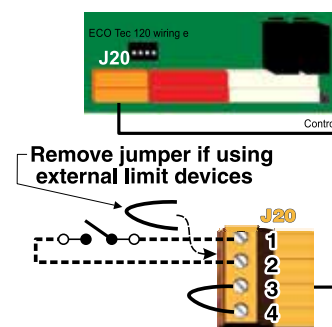

See [Figure 19, page 56](#) for details.



Field Wiring (see wiring diagram, [Figure 19, page 56](#)) (continued)

Terminal Block Wiring (continued)

To cause **AUTOMATIC** reset: Connector J20 #3 & #4

The control will reset automatically after circuit is interrupted.

1. Remove factory-installed jumper and connect isolated contacts of external limits across J20 pins 3 and 4 to cause the control to shut down the boiler on limit opening, then automatically restart 150 seconds after the limit closes.
2. See drawing at right and wiring diagram ([Figure 19, page 56](#)).

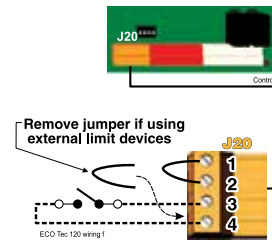

See [Figure 19, page 56](#) for details.

H. Low water cutoff (LWCO) – Sensor (supplied with boiler) & alternate (installer supplied)

Connector J21 (optional) & Connector J9 (optional)

1. Install a low water cut-off (optional) (see boiler manual [Figure 13, page 21](#); [page 58](#) for further installation instructions)
2. Connector J9 - An LWCO sensor is supplied with the boiler and is recommended to be installed. Connect this supplied LWCO sensor to connector J9. A jumper is factory installed and must be removed before connecting the LWCO sensor .
3. Connector J21 (optional) wiring Weil-McLain LWCO Kit:
 - a. Use the Weil-McLain Low water cut-off kit listed in the back of this manual when an alternate LWCO device is desired. It includes a probe-type low water cut-off and provides a simple harness connection for the wiring.
 - b. Connect as shown at bottom center in the control wiring diagram ([Figure 19, page 56](#)).
4. Wiring another LWCO - must have isolated contact:
 - a. Other low water cut-offs can be used with the Evergreen® Pro only if the device uses an isolated contact for the LWCO function.
 - b. Connect as shown at bottom right.

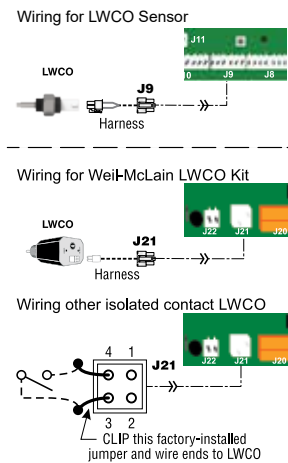

See [Figure 19, page 56](#) for details.

I. Alarm contacts – OPTIONAL

Connector J18 #4 & #5

1. The control's alarm dry contact (J18, terminals 4 and 5) closes when the boiler enters manual lockout only.
2. Connect these terminals for remote alarm notification.
3. Contact electrical ratings: 24VAC or less; 0.5 amp or less.

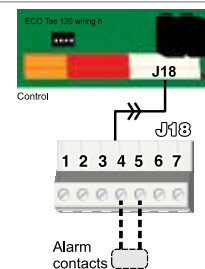

See [Figure 19, page 56](#) for details.

J. Additional heat demand contacts – OPTIONAL

Terminal Block J18 #6 & #7

1. The circuit board can be set to activate another heat source using its additional heat demand dry contacts through terminal block J18 pins 6 & 7.
2. Connect these terminals to call for heat from the other heat source.
3. Contact electrical ratings: 24VAC or less; 0.5 amp or less.
4. Set the control to activate the heat demand contacts as needed.
5. For Additional Heat Demand, refer to setup in the control section on [page 81](#) for more information.

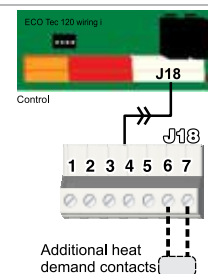

See [Figure 19, page 56](#) for details.



Field Wiring (see wiring diagram, [Figure 19, page 56](#)) (continued)

Terminal Block Wiring (continued)

K. Proof of closure (*flow switch and/or CAD*)

Jumper on Connector J18

1. A flow switch or combustion air damper (CAD) interlock can be configured by removing the jumper on connector J18 and wiring components as shown at right and in the wiring diagram ([Figure 19, page 56](#)).
2. No control settings are required when using a flow switch.
3. Recommended configuration of the control for a CAD interlock:
 - a. Assign **INPUT 3** as a **AUX PUMP/OUTPUT** function.
 - b. For the **AUX PUMP/OUTPUT** operating mode, select local or **System Damper** for use with CAD Interlock. This ensures the damper will be activated any time the boiler is called on to fire.
 - c. **OUTPUT 3** will provide 120VAC to the damper motor. Use an isolation relay if damper motor requires another voltage or more than 2.0 amp if using 120VAC.
 - d. For multi-boiler wiring of CAD interlock, wire all Proof of Closure inputs in series with the endpoint devices and each boiler's Closure Switch input.

NOTICE

* The devices used must provide electrically isolated contacts, because the J18 jumper circuit carries 5 VDC.

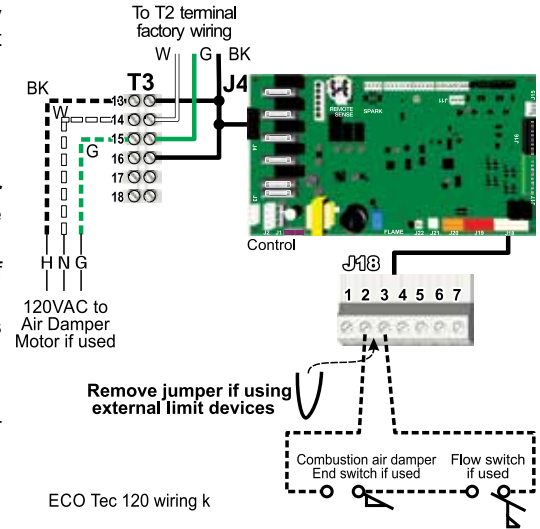

See [Figure 19, page 56](#) for details.

L. 0–10 VDC Remote TARGET input – *OPTIONAL*

Connector J16 #5 & #6

1. See illustration at right and [Figure 19, page 56](#) (wiring diagram) for details.
2. Remote target using 0–10VDC input requires a 0–10VDC input signal at J16-5/6 as shown at right.
 - a. The input positive connection must be at J16 terminal 6 and the common connection at terminal 5.
3. This illustration also shows how to connect TT or end switch contacts at INPUT 1, INPUT 2, INPUT 3 and INPUT 4.
 - a. If a Heat/Indirect DHW demand is required, connect the demand's dry contact to an unused input on the control and its pump/valve to the respective output. Then assign and setup a priority to the input using the Wizard or manually through the contractor menu.
 - b. A dry contact heat demand must be applied to one of the inputs in order to initiate a call for heat.
4. The 0–10VDC signal is used to adjust the supply target temperature, using the TARGET ADJUST setting. Set TARGET ADJUST during the WIZARD or manually in the PRIORITY SETTINGS menu for the desired system/ priority.
 - a. Many options are available for configuring the control. The following is a suggested setup that uses factory default settings as much as possible.
 - b. Use PRIORITY 1 for the Indirect DHW heating system when used. This priority's default values are set for Indirect DHW, direct-piped to the boiler. Verify that settings are suitable for the application, change if needed.
 - c. Use PRIORITY 2 for the heating systems.
 - d. The factory default settings for PRIORITY 2 or 3 make either priority a good choice for space heating applications. Set PRIORITY 2/3 values to the following:
 - Set TARGET ADJUST value to 0–10V.
 - Set VOLTS FOR MAX TARGET at the voltage that will call for the highest target temperature. Set MAX TARGET TEMP at this temperature.
 - Set VOLTS FOR MIN TARGET at the voltage that will call for the lowest target temperature. Set MIN TARGET TEMP at this temperature.
 - For voltages between VOLTS FOR MAX and VOLTS FOR MIN, the target temperature will range proportionately between MAX TARGET TEMP and MIN TARGET TEMP.

TT or end switch inputs (INPUTS 1, 2, 3 and 4)
With External 0-10VDC inputs

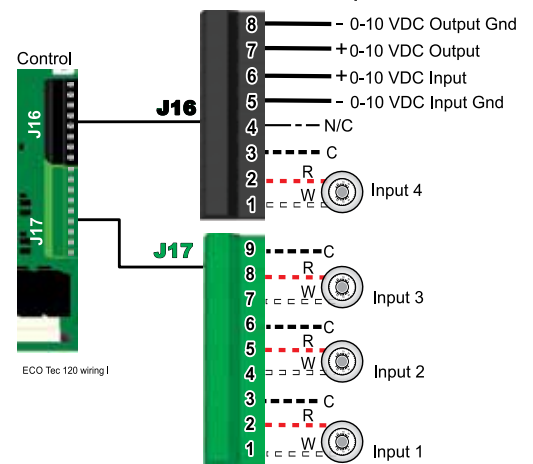

See [Figure 19, page 56](#) for details.

NOTE: The 0–10VDC signal replaces the Outdoor Temp sensor as the target temperature modifier (TARGET ADJUST setting). The control does not control target.



Field Wiring (see wiring diagram, [Figure 19, page 56](#)) (continued)

Terminal Block Wiring (continued)

M. 0–10 VDC Remote MODULATION input – *OPTIONAL*

Connector J16 #5 & #6

1. See illustration at right and [Figure 19, page 56](#) for details.
2. This illustration also shows how to connect TT or end switch contacts at INPUT 3 and INPUT 4 for other uses.
3. Note that using 0–10VDC input replaces INPUT 2 for generating a heat demand. Do NOT wire any input to INPUT 2 as shown at right.
4. Remote modulation requires a 0–10VDC input signal at J16-5/6 as shown.
 - a. The 0–10VDC input positive connection must be at terminal 6 and common connection at terminal 5.
5. Control setup:
 - a. In the System Settings menu, select INPUT 2 and change SOURCE to 0-10v. This must be done after the Wizard is complete. See [page 77](#) for System Settings menu information.
6. Operation:
 - a. The boiler comes on at 0.9VDC and turns off at 0.5VDC. 1 VDC = 10% input. 10 VDC = 100% input. These voltage settings are not adjustable.
 - b. OUTPUT 2 (120VAC) is activated and deactivated as the heat demand is turned on and off.

NOTE: The control can be configured to use either 0–10VDC for target operation (see previous section) or modulation, **but not both**.

TT or end switch inputs (INPUTS 1, 3 and 4) 0-10VDC Inputs

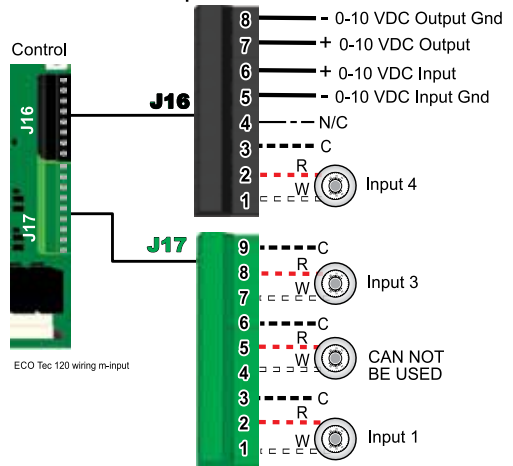

See [Figure 19, page 56](#) for details.

N. 0–10 VDC Output

Connector J16 #7 & #8

1. See illustration at right and [Figure 19, page 56](#) for details.
2. Control setup – lead/lag:
 - a. 0–10 Vdc Output functionality allows classic lead/lag system operation, and allows for cooperation with other heat sources that utilize 0-10 Vdc inputs as a source.
 - b. Adjust MAX RATE VOLTS to desired maximum voltage output. Adjust MIN RATE VOLTS to desired minimum voltage output.
3. Operation – lead/lag:
 - a. The 0–10 Vdc Output only activates when AHD is set to be used, a call for heat that uses AHD is active and Temp Dependent is set to Yes. Valid systems sensors must be present.
 - b. The 0-10 Vdc Output will follow the requested modulation rate, with 10% = Min Rate Volts, and 100% = Max Rate Volts. Voltages between are scaled accordingly.
4. Control Setup - Variable Speed Boiler Pump
 - a. 0-10 Vdc Output functionality allows for control of a variable speed boiler pump.
 - b. Connect the output to the 0-10 Vdc input of the pump.
 - c. For setup and tuning of variable speed boiler pump parameters, refer to [page 11](#).
5. Operation - Variable Speed Boiler Pump
 - a. VARIABLE SPEED MAX RATE VOLTS is desired voltage delivered to the pump when at High Fire.
 - b. VARIABLE SPEED MIN RATE VOLTS is desired voltage delivered to the pump when at Low Fire.
 - c. VOLTS WHEN BURNER OFF is desired voltage delivered to the pump when the burner is not active.
 - d. When the burner is active, the voltage output scales based on the boiler rate and the constraints of VARIABLE SPEED MIN/MAX RATE VOLTS.

TT or end switch inputs (INPUTS 2, 3 and 4) 0-10VDC Outputs

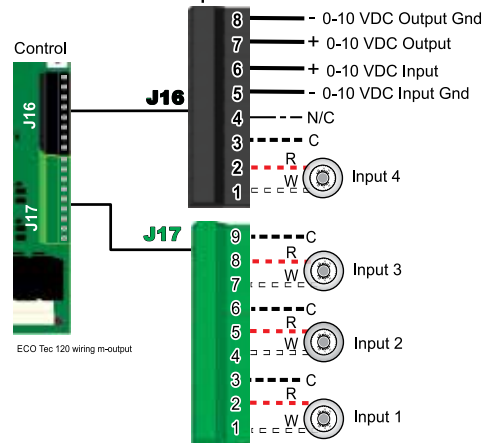

See [Figure 19, page 56](#) for details.



Field Wiring (see wiring diagram, **Figure 19, page 56**) (continued)

Terminal Block Wiring (continued)

O. Multiple Boiler and the Modbus Connection

Connector J12

- The Unity 2.0 control is capable of multiple boiler communication and can control up to eight Unity 1.0 or 2.0 control boilers in one installation. A boiler with a Unity 2.0 control **MUST** be the Master boiler in these applications.
- The boiler control is also capable of Building Management System (BMS) communication. For applications using either BMS or Multi-Boiler, use the pre-installed BMS/Multi-Boiler communication board.
- Wiring for RS485 communication harness endpoint circuit board is as follows:
 - JP4-1 = A2 (RS485 Multi-boiler Bus A+)
 - JP4-2 = B2 (RS485 Multi-boiler Bus B-)
 - JP4-3 = GND (RS485 Multi-boiler Bus GND)
 - JP4-4 = A3 (RS485 Multi-boiler Bus A+)
 - JP4-5 = B3 (RS485 Multi-boiler Bus B-)
 - JP4-6 = GND (RS485 Multi-boiler Bus GND)
 - JP4-7 = GND (BMS Ground)
 - JP4-8 = BMS B (BMS B-)
 - JP4-9 = BMS A (BMS A+)
- Boiler to boiler wiring connections (see wiring at right):
 - Use shielded 3-wire cable. Do not exceed 1,000 feet length.
 - Connect 3-wire cable between Boiler-to-Boiler OUT (JP4-GND, B2, A2) on one boiler to Boiler-to-Boiler IN (JP4-GND, B3, A3) on the next boiler.
 - Continue this wiring until all boilers are interconnected.
 - Drain line **MUST** be installed to proper ground to ensure proper communication. It is suggested to do this on the Master boiler only. Do **NOT** ground on the Master **AND** final boiler.

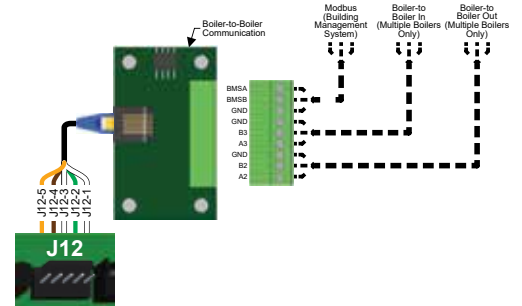

3

NOTICE

DO NOT return last shadow's wires to the Master's A3/B3/GND ports! This will create a communication loop, which will cause duplication of information and clashes in communication. The result is undesired and unknown behavior, up to and including complete loss of communication.

- For applications using BMS, the terminals on the control are:
 - J12-1 = BMS A+
 - J12-2 = BMS B-
 - J12-5 = BMS Ground
- The control is equipped with MODBUS communication to communicate with a BMS.
- Use terminal JP4 (JP4-BMS A+, BMS B-, GND) to wire to the BMS control.
- If the BMS uses BACnet protocol, install a BACnet converter between the BMS and the MODBUS-to-BMS terminals on JP4.
- Navigate to the Modbus Setting screen on the display. This is accessed via the contractor menu by pressing and holding the WM Logo from the home screen.
- Adjust all necessary Modbus settings to match the BMS system being utilized.

P. Touch screen display connection

Connector J13 or J14

- The electronic color touch screen display is factory wired to the control and is connected to the J13 or J14 connector.
- The Display harness is wired to a spring terminal on the mounting bracket. The wires are as follows: J14 is used as the example. J13 uses the same wiring pin out on the control board.
 - J14-1 White to A+
 - J14-2 Green to B-
 - J14-3 Black to C
 - J14-4 Red to R



Assembled From tested components Complete system not tested

- This device complies with Part 15 of the FCC Rules. Operation is subject to the following two conditions: (1) this device may not cause harmful interference, and (2) this device must accept any interference received, including interference that may cause undesired operation.

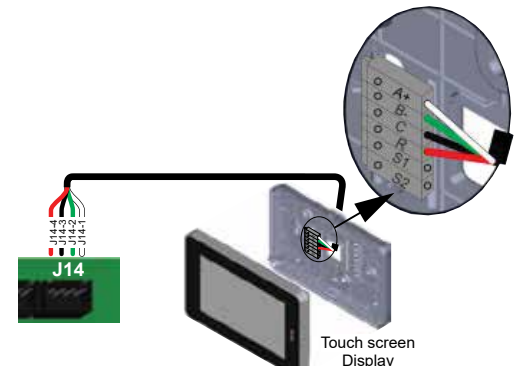



Wiring Diagram - Schematic

Figure 19 Schematic wiring diagram

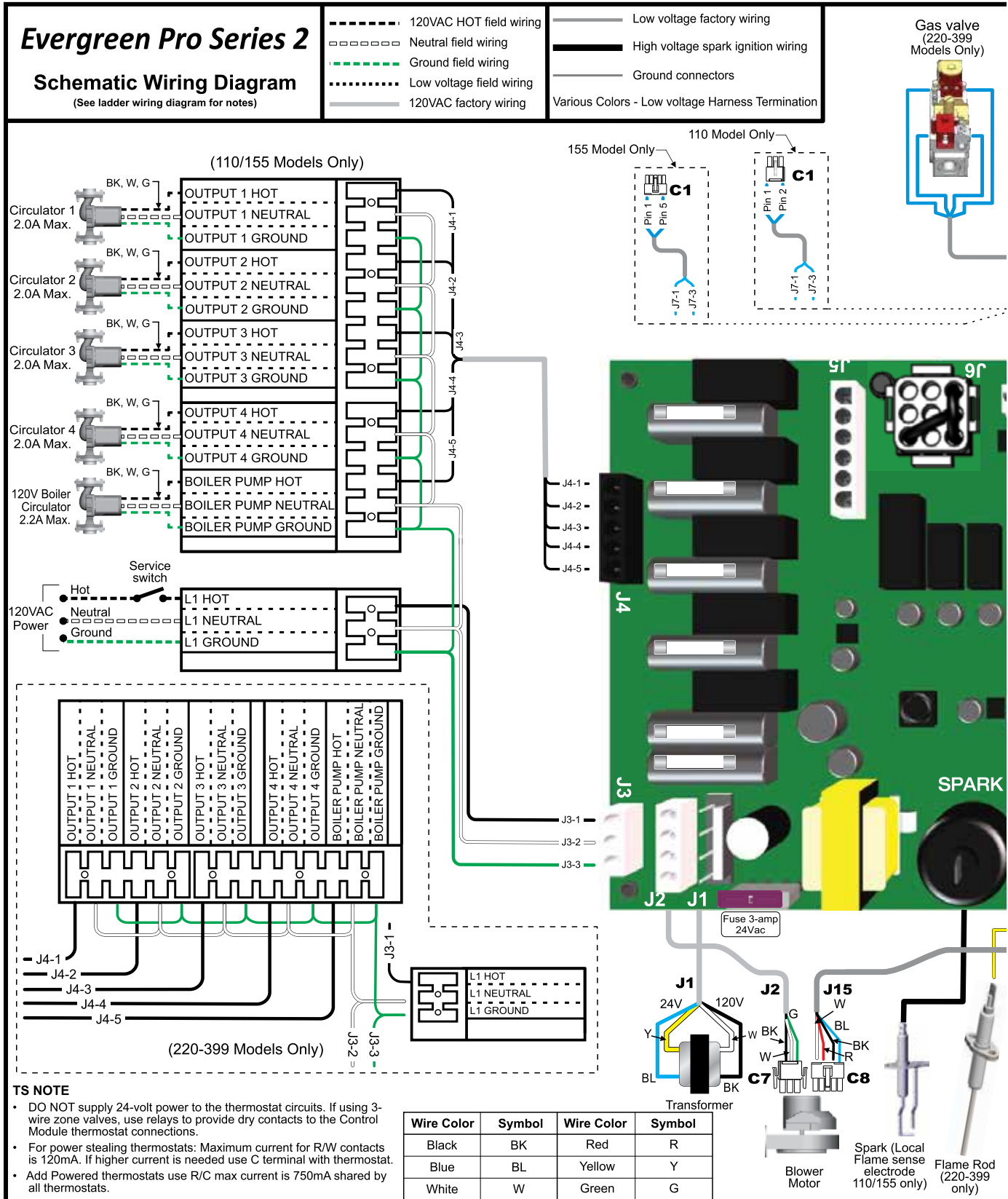



Wiring Diagram - Schematic (continued)

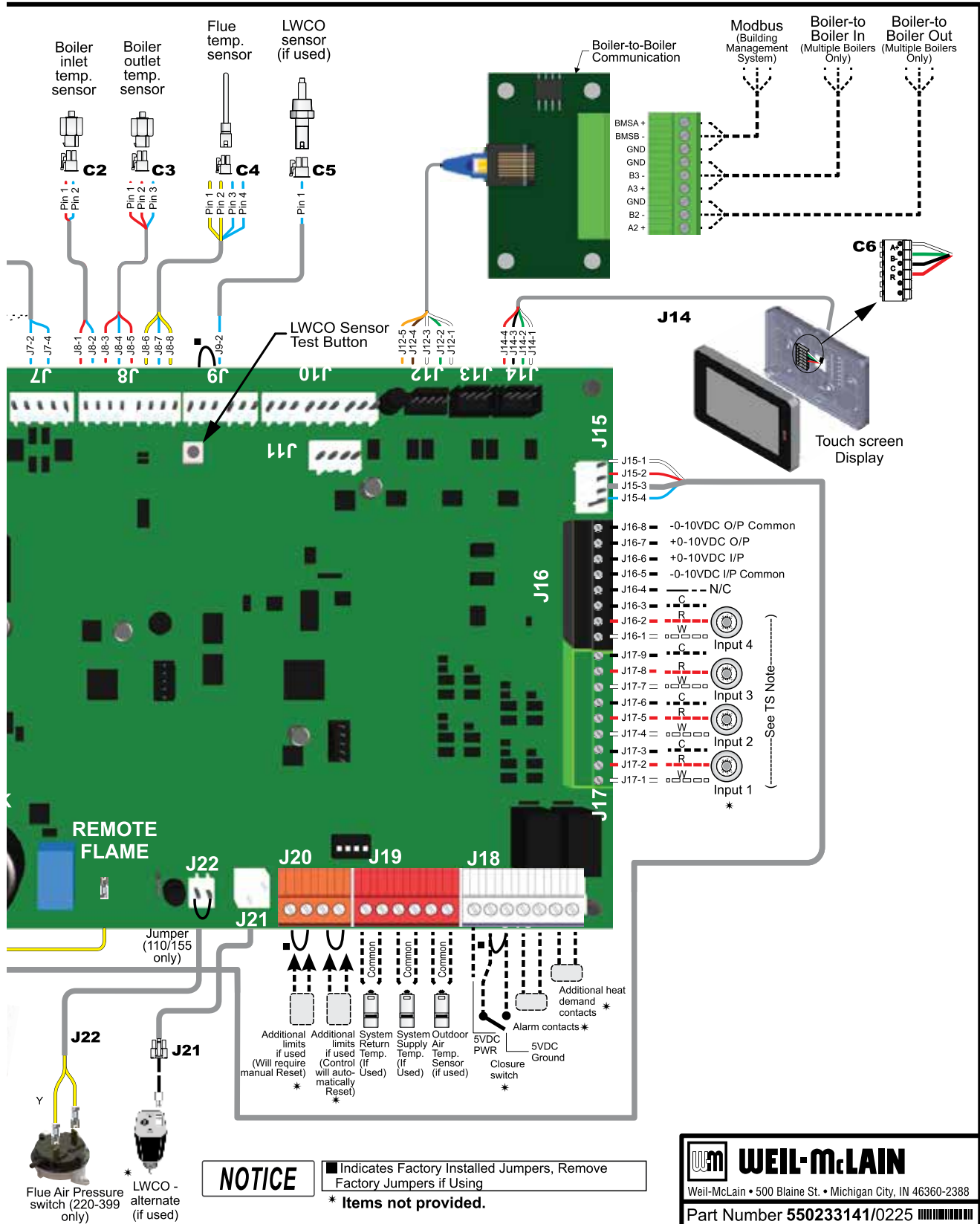

3

WEIL-McLAIN
 Weil-McLain • 500 Blaine St. • Michigan City, IN 46360-2388
 Part Number 550233141/0225



Wiring Diagram - Ladder

Figure 20 Ladder wiring diagram (see **Figure 19, page 56** for schematic wiring diagram)

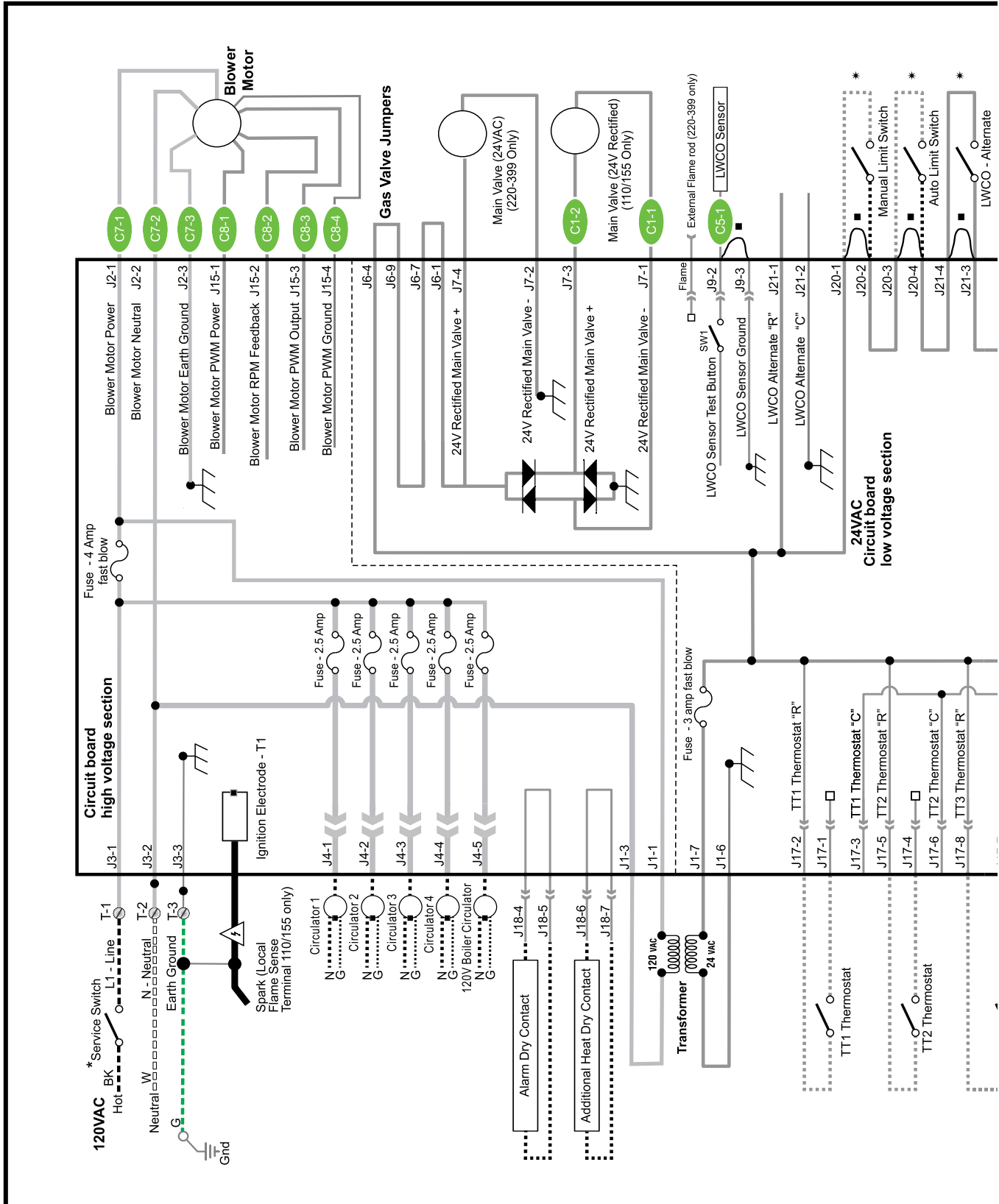



Wiring Diagram - Ladder (continued)

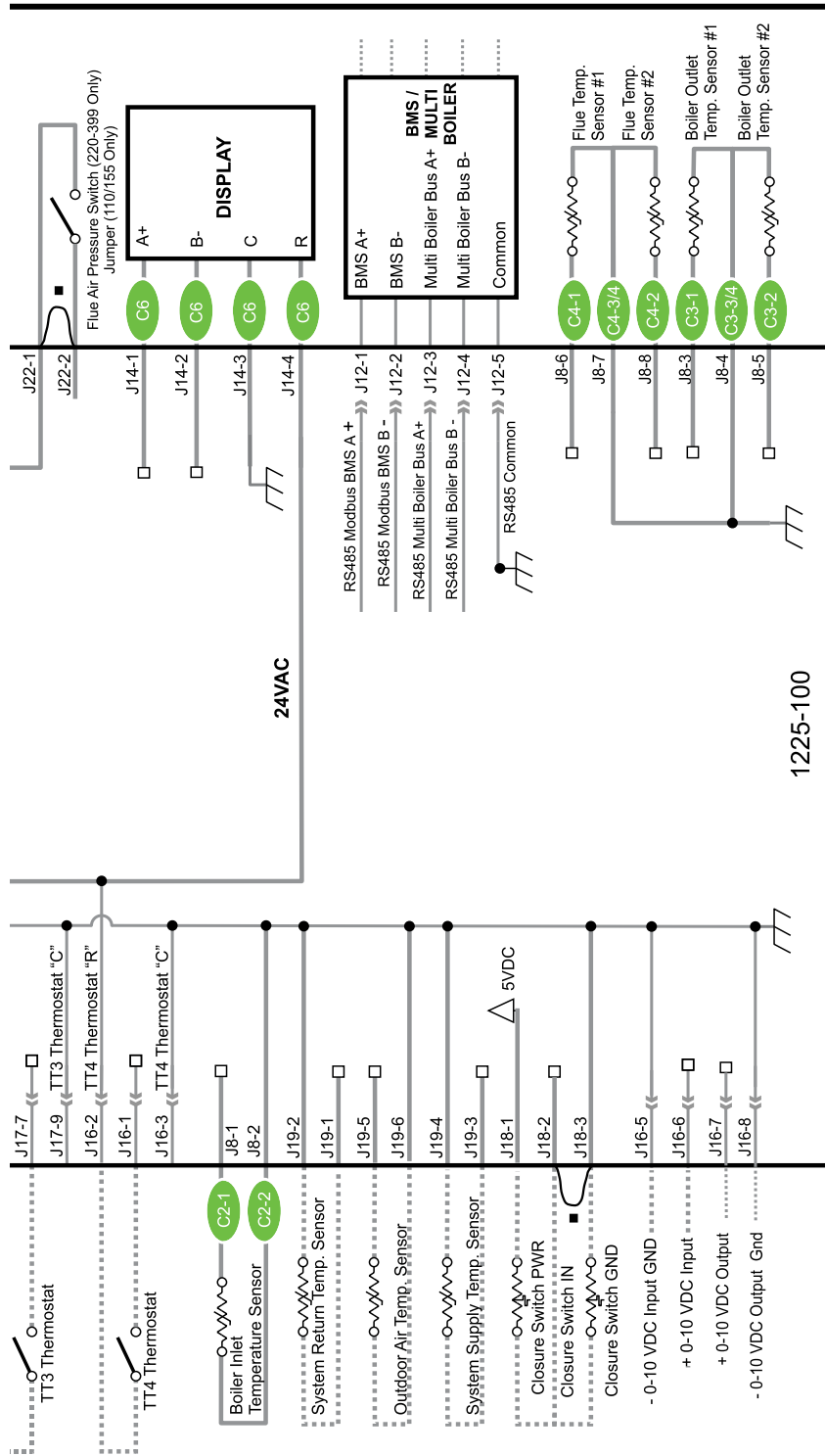

Wire Color	Symbol	Wire Color	Symbol
Black	BK	Red	R
Blue	BL	Yellow	Y
White	W	Green	G

Evergreen Pro Series 2 Ladder Wiring Diagram



Electrical shock hazard — can cause severe injury or death. Disconnect power before installing or servicing.

NOTICE

- All contacts shown without power applied.
- Indicates Factory Installed Jumpers, Remove Factory Jumpers if Using
- * Items not provided.

NOTES (for Schematic and Ladder Diagrams)

1. All wiring must be installed in accordance with:
U.S.A. — NEC ANS/NFPA 70 - latest edition and any other national, state, or local code requirements.
Canada — CSA C22.1 C.E.C. Part 1 and any other national, provincial, or local code requirements.
2. Connect additional limits (if used) between terminals J20-1 and J20-2 if the boiler circuit board is to manual reset on limit action. Connect between terminals J20-3 and J20-4 for automatic reset. Remove jumper across terminals used.
3. If any of the original wire as supplied with the appliance must be replaced, use minimum 105° C wire or equivalent. Exceptions: Ignition lead wire, ignition ground wire, and flame sense wire must be replaced only with Weil-McLain parts.
4. Thermostat anticipator setting (single zone) — set anticipator for 0.1 amps.
5. For multiple zoning, use either zone valves or circulators. Refer to the component manufacturer's instructions and the manual for application and wiring suggestions.
6. Refer to control component instructions packed with the boiler for application information.
7. To field wire a non-powered (isolated contact) low water cutoff, clip the factory jumper in the factory-installed Molex plug, strip the wires, and connect to the low water cutoff limit terminals.

Legend for ladder wiring diagram only

- 120VAC field wiring
- Low voltage field wiring
- Field ground connectors
- 120VAC factory wiring
- Low voltage factory wiring
- High voltage spark ignition wiring
- Ground connectors
- Harness Connector and Pin



WEIL-McLAIN

Weil-McLain • 500 Blaine St. • Michigan City, IN 46360-2388

Part Number 550233143/0225



Zoning with the Evergreen Pro Control

A. Zoning with CIRCULATORS, suggested applications

Four Space Heating Zones (no Indirect DHW)

(110/155 models shown, for 220-399, reference the wiring diagram).

1. Review wiring information on [page 49](#) (120VAC outputs) and [page 50](#) (24VAC inputs).
2. The configuration at right uses the four input/output pairs to receive thermostat inputs on J17-1/2, J17-4/5, J17-7/8 and J16-1/2; and circulator outputs as shown.
3. Choose the space heating system type that matches the heating system during the WIZARD setup or manually in the PRIORITY 2 menu in the System Settings menu.
4. Use the factory default settings for the system type chosen, or change if needed.

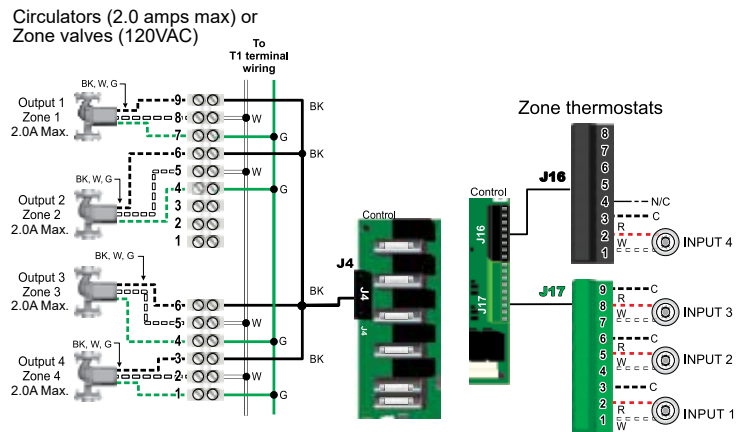

Three Space Heating Zones Plus Indirect DHW Piped Directly to Boiler

(110/155 models shown, for 220-399, reference the wiring diagram).

1. Review wiring information on [page 49](#) (120VAC outputs) and [page 50](#) (24VAC inputs).
2. The configuration at right uses INPUT 3 and 4 for space heating thermostats. INPUT 1 uses the input from a DHW aquastat.
3. System Settings 2, 3 and 4 to PRIORITY 2. To set up PRIORITY 2, choose the space heating system type that matches the heating system during the WIZARD setup or manually in the PRIORITY 2 menu in the System Settings menu.
4. Assign INPUT 1 to PRIORITY 1.
5. Use the factory default settings for DHW and for the heating system type chosen, or change if needed.

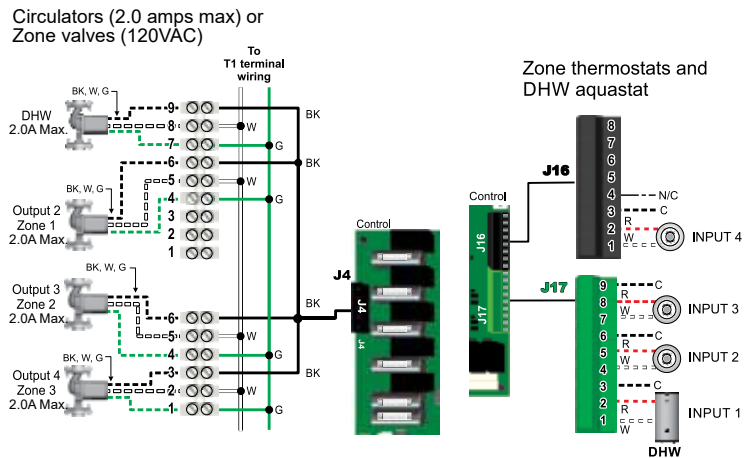



Zoning with the Evergreen Pro Control (continued)

B. Zoning with ZONE VALVES, suggested applications

Two Space Heating Zones (no Indirect DHW)

(110/155 models shown, for 220-399, reference the wiring diagram).

1. Review wiring information on [page 49](#) (120VAC outputs) and [page 50](#) (24VAC inputs) and [page 50](#) (24VAC inputs).
2. The configuration at right uses INPUT 2, 3, and 4 for space heating thermostats. INPUT 1 is reserved here for configuring the operation of the system circulator.
3. System Settings 2, 3 and 4 to PRIORITY 2. To set up PRIORITY 2, choose the space heating system type that matches the heating system during the WIZARD setup or manually in the PRIORITY 2 menu in the System Settings menu.
4. Use the factory default settings for the heating system type chosen, or change if needed.
5. Assign INPUT 1 to AUX PUMP/OUTPUT. Then select INPUTS PRIORITY SETTING when prompted for when to activate the output. This will cause the system pump to run when either of the zones calls for heat. Confirm that Priority 2 RUN AUX PUMP/OUT is set to YES.
6. INPUT 1, J17-1/2, cannot be used for a wired connection because it is being used in the control setup to run the system circulator.

⚠ WARNING

The system must be equipped with a by-pass pressure regulating valve. Flow can occur with zone valves closed.

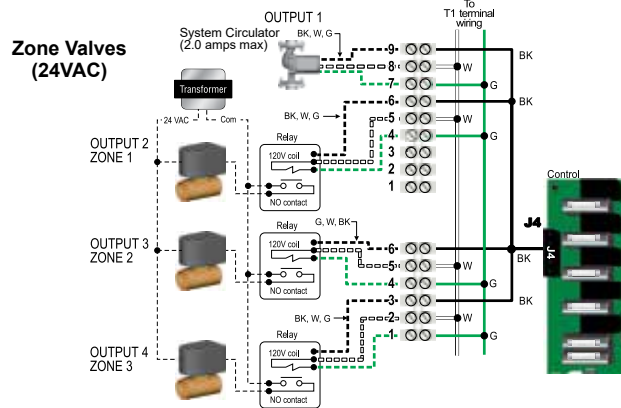
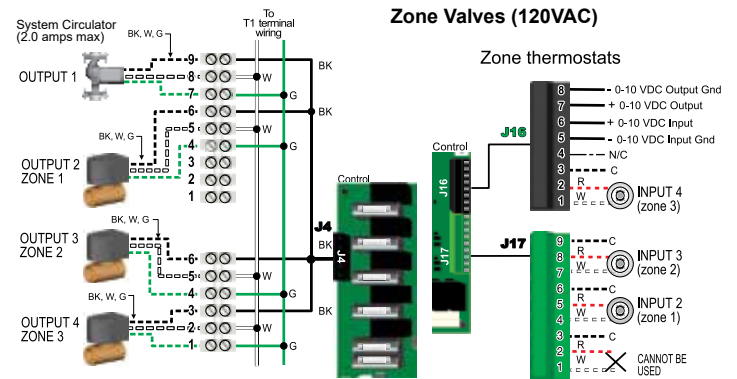



This page intentionally left blank

3



SECTION 4 Operation

This section is intended to provide instructions for control setup and boiler startup procedures.

Section Contents

Control Setup and Operation63
Multiple Boiler Operation63
Available Control Settings and System Presets67
NAVIGATION Menus69
CONTRACTOR Menus71
BOILER SETTINGS Menus72
PUMP SETTINGS Menus73
NETWORK SETTINGS Menus74
ROTATION AND SEQUENCE75
SYSTEM SETTINGS Menus77
Boiler PRIORITY Menus78
AUX Pump/Output82
Primary Valve Control83
DIAGNOSTICS Menu84
SERVICE Menus86
SERVICE INFO86
Additional Instructions86

Control Setup and Operation

Control Overview

This manual covers boiler control operation and setup. This manual is a walk-through of the complete control setup for basic and complex boiler applications.

- Control inputs and outputs allow operation of multiple heating circuits (space heating and DHW, for example).
- Up to three priority levels can be set, providing automatic switch-over on demand. Up to four priority level for multi boiler (2 local and 2 network).
- The control responds to signals from the room thermostats, DHW aquastats (if used), boiler sensors (Boiler Out, Boiler In, flue temperature), system sensors, and outdoor temperature sensor, if used.
- The control automatically adjusts blower speed to match boiler output to space heating and DHW heating demand.
- The control provides up to four space heating zones. The control can be easily set up for operation with a DHW zone, with or without domestic priority.

- The Wizard leads through a step-by-step setup procedure designed for the application chosen.
- Context-sensitive help is available to explain the purpose of key setup items.

Multiple Boiler Operation

- The boiler has an auto detection feature for multiple boiler networks. The Master will automatically detect the presence of the other boilers wired to the network.
- There will be a 30 second to 1 minute period until the Master may see the shadow boilers.
- Each shadow boiler must be assigned a network address, from 2 through 8. The address for each boiler must be unique, NOT selected for any other boiler.
- Afterwards, the Master will build a network based on the communications shared. If a boiler loses communication, the Master will automatically re-assign the lost boiler to where it was before once it is back on the network.
- When network inputs turn on, the Master boiler will enter the Network Modulation routine.
- Three system modulation types—SERIES, PARALLEL, AND SMART.
- Using system sensors, the Master will modulate the entire network to meet the energy requirements of Network Priority 1 and Network Priority 2 inputs when they are on.
- When a Local Priority input becomes active (switch closes), modulation for that input is not controlled by the Master, but instead is left to that local boiler using its own local Boiler Inlet and Outlet sensors.





Multiple Boiler Operation (continued)

- Each of the four (4) inputs on the Master or any of the Shadow boilers can be assigned as Network Priority 1 or 2 or assigned as Local Priority 1 or 2. Network Priority settings are common across all the boilers. These Network Priority settings can only be adjusted from the Master boiler.

Control Setup

1. Set control parameters using the Wizard option provided on initial start-up, or manually enter parameters using control menus. See the following pages for more information.
2. See Express Setup instructions in this manual for systems and minimum settings required.

WARNING

BOILER MODEL, ALTITUDE, and FUEL TYPE are critical settings. Failure to set these correctly can result in severe personal injury, death, or substantial property damage.

NOTICE

Ensure the control is set for the proper water temperatures for the system. Excessive water temperature can result in significant property damage in some applications.

NOTICE

Multi-temperature systems — If the heating system includes both circuits that require lower temperature water and higher temperature circuits, protect the low-temperature circuits with limit controls that are wired to an control external limit circuit. Failure to provide regulation can result in substantial property damage.



Essential Control Settings

Figure 21 Boiler essential settings, REQUIRED on initial start-up.

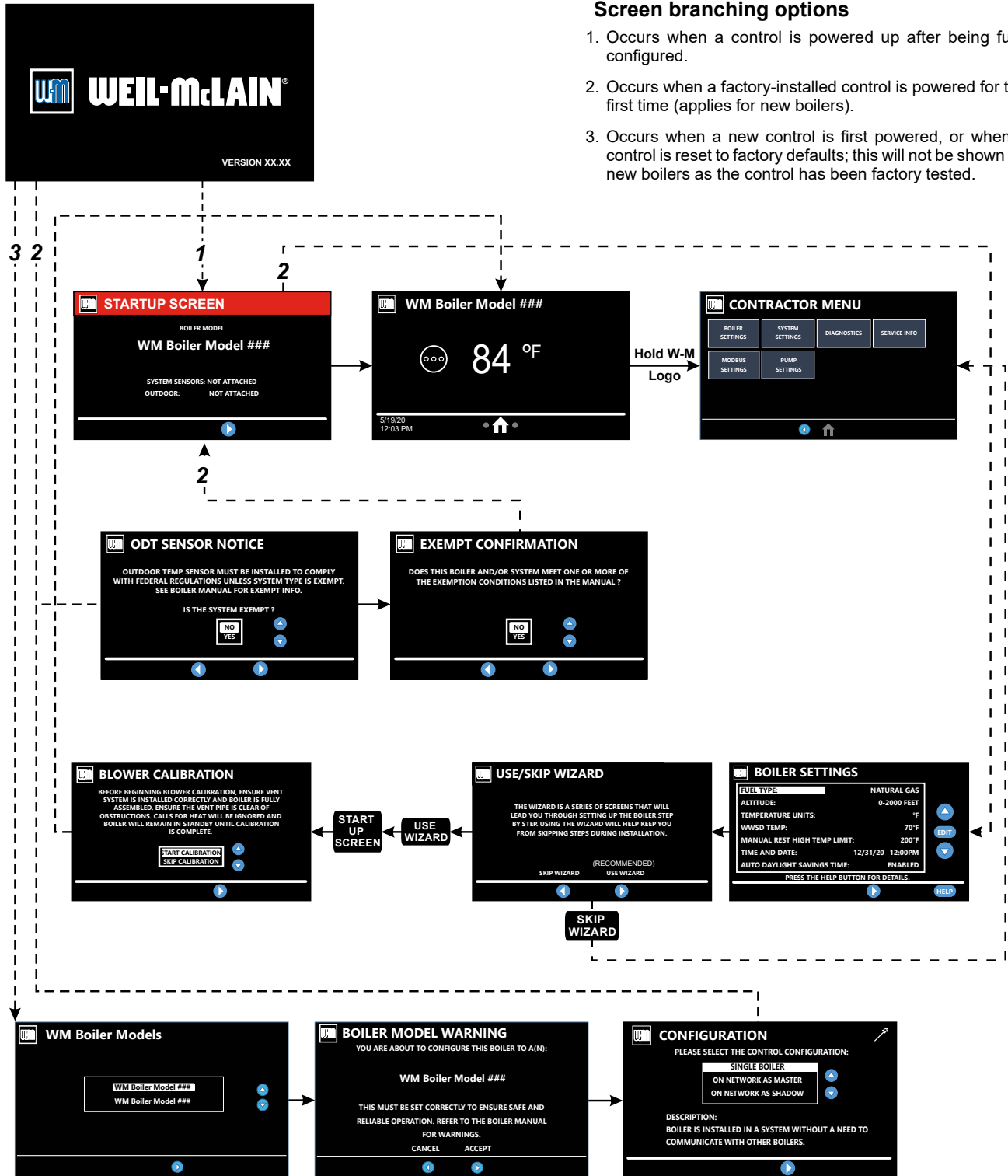

Screen branching options

1. Occurs when a control is powered up after being fully configured.
2. Occurs when a factory-installed control is powered for the first time (applies for new boilers).
3. Occurs when a new control is first powered, or when a control is reset to factory defaults; this will not be shown on new boilers as the control has been factory tested.



Screens shown above are typical only.
Actual screens depend on control settings chosen.



Control Settings Menus

Figure 22 Outdoor reset operation

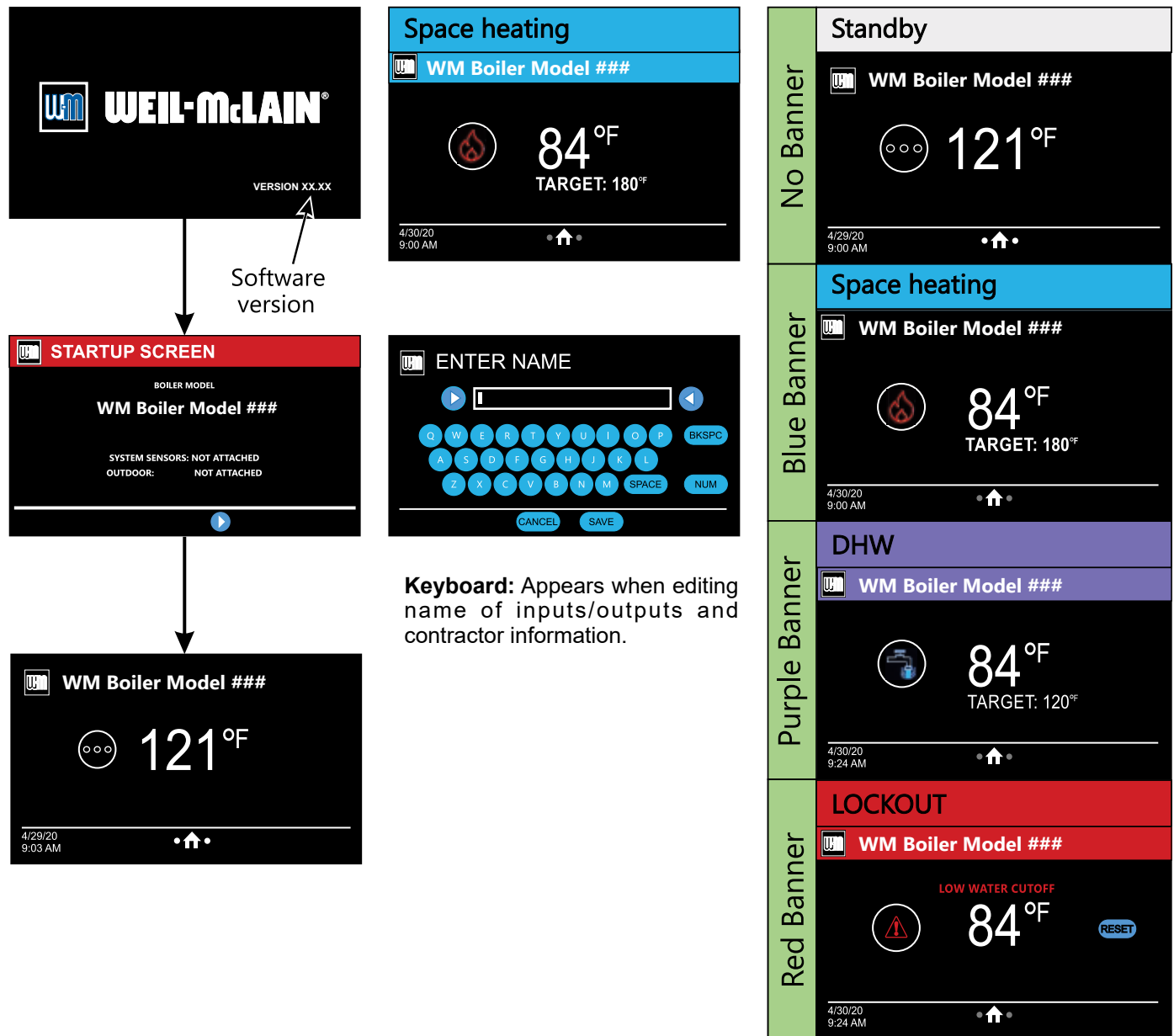

Navigation Controls

Swipe: Slide finger left or right on the screen to navigate forward and backward on applicable screens.

Press: Touch icons on screen to perform specified action.

Scroll: Place finger on slide bar empty space and hold to scroll. Applicable screens can also be swiped up or down to scroll.

Double tap: Applicable on editable parameters. Allows user to enter edit mode by double tapping parameter.

Screens shown above are typical only.
Actual screens depend on control settings chosen.



Available Control Settings and System Presets

Table 8 Control priority settings

Priority Settings			
Parameter Name	Range and Options	Default Setting	Units
ASSIGNED INPUTS	1, 2, 3, 4, 0-10V, FLOW	—	—
SYSTEM TYPE	See System Type Presets	OFF	—
TARGET MODULATION SENSOR	System Supply, Boiler Out	System Supply if detected, Boiler Out if not	—
TARGET ADJUST	Outdoor Temp, 0-10V, none	Outdoor Temp (If attached)	—
MAX TARGET TEMP	See System Type Presets	See System Type Presets	°F
MIN TARGET TEMP	See System Type Presets	See System Type Presets	°F
OUTDOOR TEMP FOR MIN TARGET	50 - 100	70	°F
OUTDOOR TEMP FOR MAX TARGET	-20 to 49	0	°F
VOLTAGE FOR MAX TARGET (TARGET ADJUST)	5.0 - 10.0	10.0	V
VOLTAGE FOR MIN TARGET (TARGET ADJUST)	0.0 - 4.9	0.0	V
TARGET BOOST TIME	OFF, 1 - 240	OFF	M
SYSTEM SUPPLY OFF DIFF	5 - 15	10	°F
SYSTEM SUPPLY ON DIFF	5 - 30	10	°F
MAX BOILER TEMP	60-185	Max Target Temp plus 5°F	°F
ADD BLR DIFF	2 to 10	5	°F
DROP BLR DIFF	2 to 10	5	°F
MOD DELAY TIME	1 to 15 minutes	2 minutes	—
STABILIZE TIME	3 to 30 minutes	5 minutes	—
ADD DELAY TIMER	30 to 240 seconds	60 seconds	—
DROP DELAY TIMER	30 to 240 seconds	60 seconds	—
BOILER OUT OFF DIFF	2 - 15	5	°F
BOILER OUT ON DIFF	2 - 30	5	°F
COLD START ERROR	0 - 150	50	°F
RUN 0-10V BOILER PUMP	YES, NO	No	—
RUN 120V BOILER PUMP	YES, NO	Yes	—
RUN AUX/PUMP OUT	YES, NO	No	—
PRE PUMP	OFF, 1 - 240	OFF	S
POST PUMP	OFF, 1 - 240	30	S
MAXIMUM RATE	11 - 100	100	%
MINIMUM RATE	10 - 99	10	%
ADDITIONAL HEAT DEMAND ACT CONTACT	OFF, 1ST, 2ND, Outdoor Temperature	OFF	—
RESPONSE TIME	OFF, 1 - 240	OFF	M
TEMP DEPENDENT	YES, NO	NO	—
OUTDOOR TEMP SETPOINT	0 - 50	15	°F
ACT CONTACT BELOW SETPOINT	1st, 2nd, OFF	1st	—
ACT CONTACT ABOVE SETPOINT	1st, 2nd, OFF	2nd	—





Available Control Settings and System Presets (continued)

Table 9 Available settings

Other Available Settings		
Menus and Items	Range and Options	Default Setting
MAX SYS MBH (NETWORK PRIORITIES ONLY)	AUTO or 100 to 32,000 MBTU's	AUTO
MIN BOILERS (NETWORK PRIORITIES ONLY)	1 to 8	1
MAX RATE VOLTAGE	5.0 - 10.0	10.0
MIN RATE VOLTAGE	0.0 - 4.9	1.0
Network Settings (page 74)	Range and Options	Default Setting
CONTROL TYPE	Single, Master, Shadow	—
BOILER ADDRESS	1 to 8	—
THIS BOILERS NET MAX ON TIME	Off, 1 to 240	30
THIS BOILERS NET MIN ON TIME	Off, 1 to 240	15
THIS BOILERS MAX RATE ON NET	100% to 21%	96%
THIS BOILERS MIN RATE ON NET	20% to 99%	20%
Rotation and Sequence (page 75)	Range and Options	Default Setting
SEQUENCE TYPE	Smart, Parallel, Series	None
BASERATE HIGH	Auto, 20% to 100%	N/A
BASERATE LOW	20% to 100%	N/A
LEAD BOILER ROTATE	Off, By Boiler, Total Hours, Incremental Hours	Total Hours
ROTATE FREQUENCY	1-30, 60, 90, 120, 150, 180, 210, 240, 270, 300, 330, 365	7
FORCE LEAD ROTATE	Yes, or No	Yes
CURRENT ORDER	Shows current rotation sequence	—
Other	Range and Options	Default Setting
INPUT 1	NONE or Single boiler – PRIORITY 1, 2, or 3 Master or shadow boiler – NETWORK PRIORITY 1 or 2 or LOCAL PRIORITY 1 or 2	—
INPUT 2		—
INPUT 3		—
INPUT 4		—
DIAGNOSTICS (page 84)		
SERVICE (page 86)		
NOTICE See detailed information about control settings and parameters on the following pages.		

Table 10 System type presets – each option shown with factory settings

System Type	8-Character Abbreviation	3-Character Abbreviation	Max Target Temp °F	OD Reset Min °F	Min Target Temp °F	OD Reset Max °F	Run 0-10V Boiler Pump	Run 120V Boiler Pump	Run AUX PUMP/ OUTPUT
Fan-coil	FAN-COIL	FCL	180	0	140	70	NO	YES	NO
Finned Tube Baseboard	FIN BASE	FTB	180	0	130	70	NO	YES	NO
Cast Iron Baseboard	IRONBASE	CIB	180	0	120	70	NO	YES	NO
Cast Iron Radiators	RADIATOR	CIR	180	0	120	70	NO	YES	NO
Radiant - slab on grade	RAD SLAB	RSG	120	0	80	70	NO	YES	NO
Radiant - thin slab	RAD SLAB	RTS	140	0	80	70	NO	YES	NO
Radiant - below floor (staple up)	RADFLOOR	RSU	160	0	90	70	NO	YES	NO
Radiant - above floor (sleeper system)	RADFLOOR	RAF	140	0	90	70	NO	YES	NO
Domestic Hot Water	DOMESTIC	DHW	180	N/A	N/A	N/A	NO	YES	NO
Custom (user defined)	XXXXXXXX (user input)	first three of user input	180	0	70	70	NO	YES	NO



NAVIGATION Menus

Figure 23 NAVIGATION menus

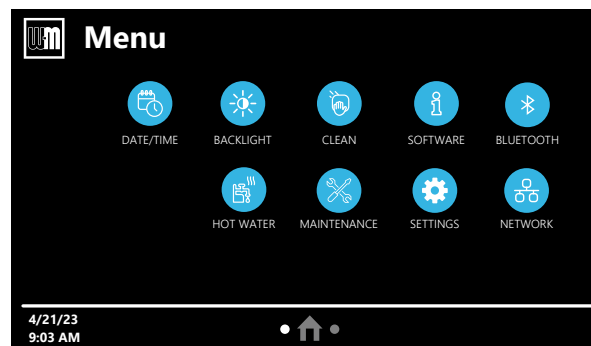
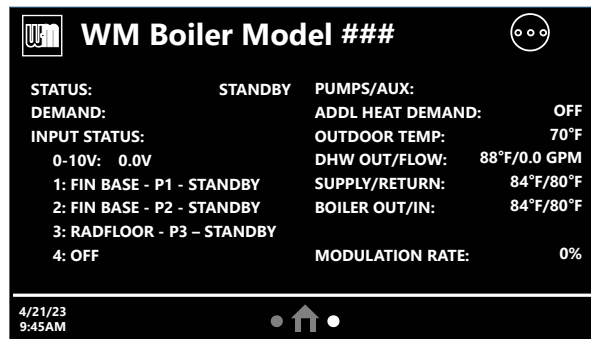
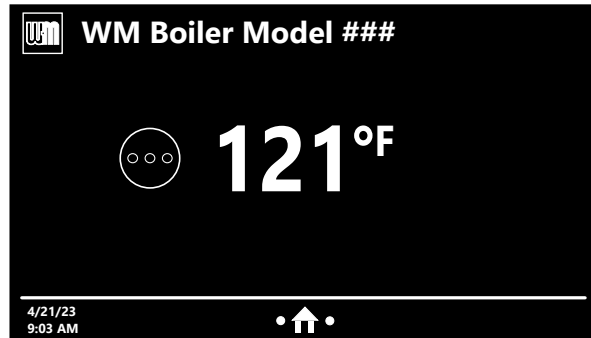

Screens shown on this page are typical only. Actual screens depend on control settings chosen.

Menu Item	Purpose
HOME SCREEN	<ul style="list-style-type: none"> Banner info Status image Fault name and reset button Time/Date Navigation buttons – 2 dots and Home Current temperature Target Temperature (when a priority is active)
BOILER INFORMATION SCREEN	<ul style="list-style-type: none"> Status: Shows the current sequence of operation status with the active priority. Input Status: Shows the current status of each call for heat. 0-10v: Shows the current 0-10v input value from external device. 1-4: Shows inputs 1 through 4, what they are assigned to, their custom names and their status. Pumps/Aux: Shows which aux/pump outputs are currently active. Additional Heat Demand: Shows whether AHD is off or on. Only appears if a priority is selected to use AHD. Outdoor Temp: Shows the current outdoor temperature sensor value. Only visible if selected to use. Supply/Return: Shows the current System Supply and System Return temperature. Only visible if selected to use. Boiler Out/In: Shows the current Boiler Out and Boiler In temperatures. Target Temp: Shows the current Target Temperature of the active priority. Mod Rate: Shows the modulation rate of the boiler's blower motor.
DATE/TIME BUTTON	<ul style="list-style-type: none"> Allows user to edit the current date and time.
BACKLIGHT	<ul style="list-style-type: none"> Allows user to edit how bright the screen is during normal operation and when dormant.
CLEAN	<ul style="list-style-type: none"> Locks the screen so nothing can be pressed for 10 seconds while the user cleans the screen.
SOFTWARE	<ul style="list-style-type: none"> Displays the current software revisions of the control and display, log file and fault file size.
NETWORK	<ul style="list-style-type: none"> Allows the user to see basic network information for firing rate and status of boilers on network, and their commanded rates from the Master.



NAVIGATION Menus (continued)

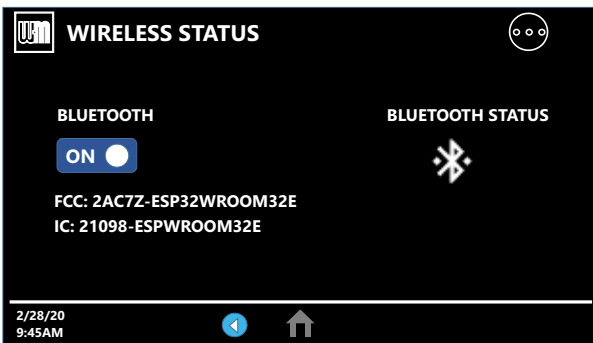
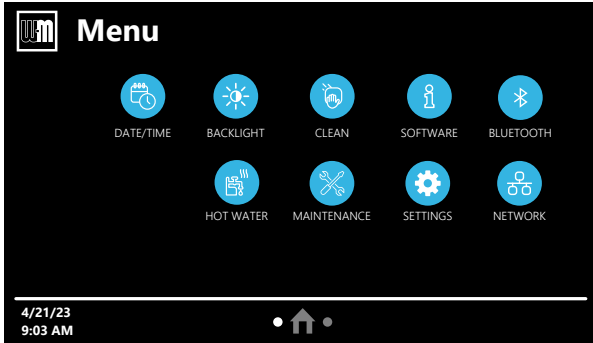

Menu Item	Purpose
<p>BLUETOOTH®</p>	<ul style="list-style-type: none"> Allows the user to turn Bluetooth ON or OFF. Swipe right from HOME and press <BLUETOOTH> to reach FCC and IC information. Bluetooth allows the user to connect remotely to the WM ProTool app for wireless communication to the boiler. The app functions include, but are not limited to, allowing the user to install the latest software for their boiler control, display, and Bluetooth radio, giving quick access to boiler information, and providing contact information to WM Technical Services.
<p>FCC</p> <p>Assembled From tested components. Complete system not tested.</p>	<p>FCC: Wireless device unique identifier registered with the U.S. Federal Communications Commission.</p> <p>IC: Wireless certification approval number unique to all devices, required for Canada.</p> <ul style="list-style-type: none"> This device complies with Part 15 of the FCC Rules. Operation is subject to the following two conditions: (1) this device may not cause harmful interference, and (2) this device must accept any interference received, including interference that may cause undesired operation.
<p>MAINTENANCE</p>	<ul style="list-style-type: none"> Allows the user to view contractor and maintenance information, as well as reset the maintenance reminder when present.
<p>SETTINGS</p>	<ul style="list-style-type: none"> Allows the user to edit temperature units, screen time out, daylight savings time and sound effect of presses.

4



CONTRACTOR Menus

Accessing Contractor Menus



Boiler Model, Altitude and Fuel Type are critical settings. Failure to set these correctly can result in severe personal injury, death, or substantial property damage.

Access contractor menus by pressing the WM Logo for seven seconds from the home screen.

Service Menu Section

Use this section to enter contractor’s information, Consumer Protection (CP) number, install date, and an automatic notice for maintenance (default is 12 months). The notice for maintenance shows on the display and automatically notifies the homeowner of the need for scheduled maintenance by the technician. Select RESET REMINDER to reset for the next maintenance date.

Figure 24 CONTRACTOR menus

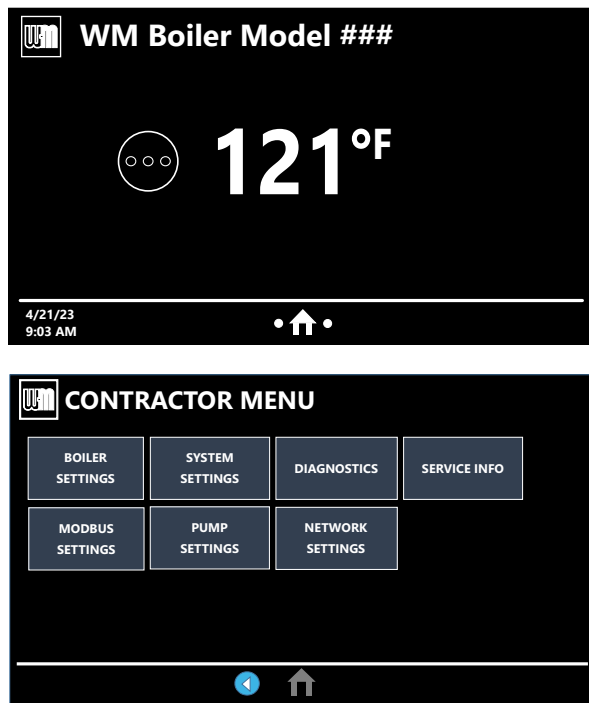

Menu Item	Purpose
BOILER SETTINGS	<ul style="list-style-type: none"> Set or change boiler model, control type, high altitude setting, ODT sensor requirement, manual reset high limit and WWSD temperature settings. Outdoor sensor temp adjustment. Restore to factory default option. Fuel type and blower calibration.
SYSTEM SETTINGS	<ul style="list-style-type: none"> These settings assign Priority 1, 2 or 3 to each of the four inputs to the control and see an overview of assigned priorities.
DIAGNOSTICS	<ul style="list-style-type: none"> Use to review current and historical information, including previous lockouts.
SERVICE INFO	<ul style="list-style-type: none"> Used to set contractor contact information, boiler information and maintenance dates.
MODBUS SETTINGS	<ul style="list-style-type: none"> Used to adjust Modbus related settings such as Baud Rate, Parity and Stop Bits, Modbus Address and turning Modbus on/off.
PUMP SETTINGS	<ul style="list-style-type: none"> Holds menu for Circulator Exercising, Freeze Protect Circulators, 0-10V Pump output, Variable Speed Max Rate Volts, Variable Speed Min Rate Volts, and Volts When Boiler Off settings. Manual Test mode shortcut button.
NETWORK SETTINGS	<ul style="list-style-type: none"> Used to adjust Max/Min Time On Net, This Boiler’s Max/Min Rate On Net, select Run 120V and 0-10V Boiler Pumps to run on or off network, and select Rotation and Sequence screen.



Screens shown on this page are typical only. Actual screens depend on control settings chosen.



BOILER SETTINGS Menus

Boiler Settings Menus Navigation

1. Access contractor menus by pressing the WM Logo for seven seconds from the home screen.
2. Select BOILER SETTINGS on the screen.
3. See Figure 25 for an explanation of control settings

⚠ WARNING

Boiler Model, Altitude and Fuel Type are critical settings. Failure to set these correctly can result in severe personal injury, death, or substantial property damage.

Figure 25 BOILER SETTINGS options

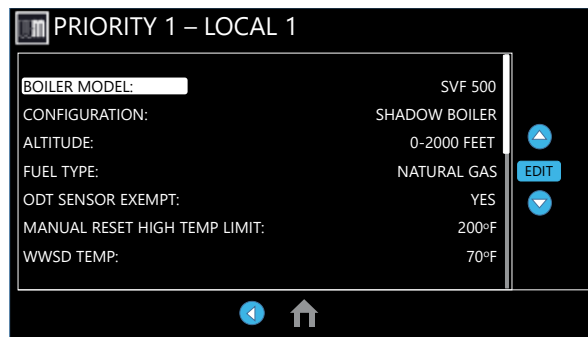
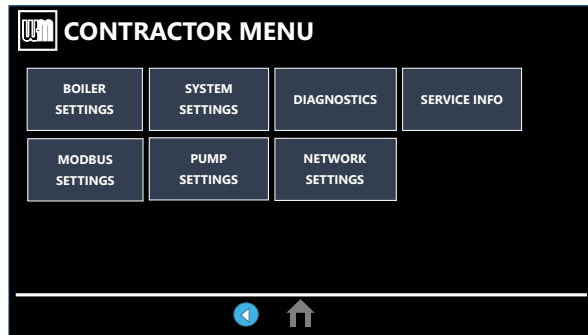

Menu Item	Purpose
BOILER MODEL	<ul style="list-style-type: none"> MUST be set to the correct model. Check the boiler model against the model listed on the boiler's rating plate. Change the selection to the correct model if incorrect. Also verify the model number on the control display at power-up.
CONFIGURATION	<ul style="list-style-type: none"> Change boiler configuration to Single boiler, Master or Shadow boiler.
ALTITUDE	<ul style="list-style-type: none"> MUST be set correctly if altitude is greater than 2,000 feet. Settings are in 500-foot increments.
FUEL TYPE	<ul style="list-style-type: none"> MUST be set to the correct fuel type. Select between Propane and Natural Gas. Follow screen instructions to change if necessary.
OUTDOOR TEMP SENSOR EXEMPT	<ul style="list-style-type: none"> Select YES only if boiler is exempt from the requirement for outdoor reset operation stipulated in Section 303 of the 2007 Energy Act.
MANUAL RESET HIGH TEMP LIMIT	<ul style="list-style-type: none"> If boiler outlet water temperature exceeds this temperature, the control will shut down the boiler and enter lockout. Changing this setting is NOT recommended.
WWSD TEMP	<ul style="list-style-type: none"> WWSD stands for warm weather shut down. It means the boiler will not be allowed to fire if the outdoor temperature is greater than the WWSD setting. When the boiler is kept off because the outdoor temperature is above WWSD, the graphic display will show WWSD, and the boiler will remain in standby until the outdoor temperature drops below WWSD temperature. WWSD does not apply to DHW systems or custom priorities. The outdoor sensor must be installed to use this function.
ADJUST OUTDOOR	<ul style="list-style-type: none"> Use this setting to calibrate the outdoor sensor when needed to compensate for variations in lead length, or for other factors that could affect total resistance in sensor circuit.
BLOWER CALIBRATION	<ul style="list-style-type: none"> Use this function to re-calibrate the blower motor for optimal blower performance. NOTE: All calls for heat must be off and boiler must be in "Standby" to use this function.
RESET FACTORY DEFAULTS	<ul style="list-style-type: none"> This screen has two options. RESTART WIZARD keeps all contractor information, time and date, run times and errors, and boiler model, and allows the user to restart the wizard from the beginning. RESET FACTORY DEFAULTS clears all information from the control including model number and returns the control to a factory received state.



PUMP SETTINGS Menus

Figure 26 PUMP SETTINGS options

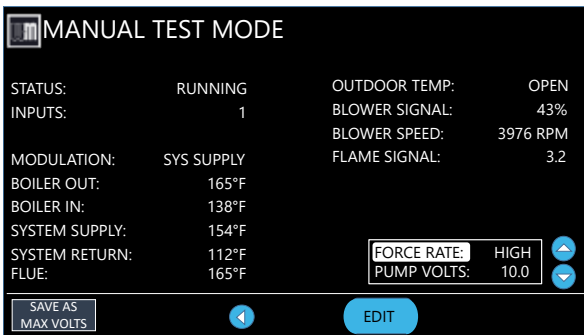
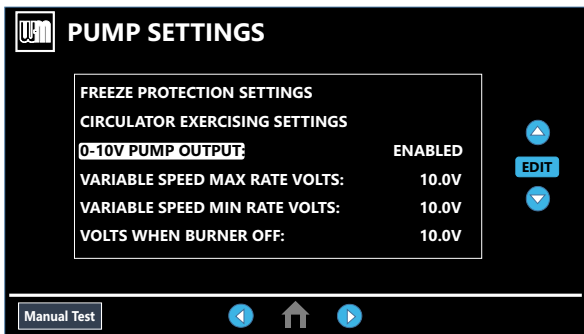
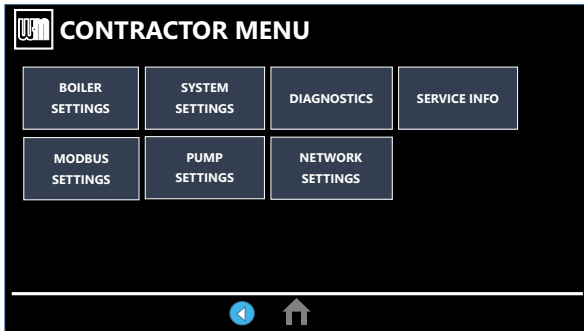

Menu Item	Purpose
FREEZE PROTECT CIRCS	<ul style="list-style-type: none"> This function automatically fires the boiler at low fire and starts the circulators chosen if the heat exchanger sensors detect a temperature less than 45°F. Burner is turned on if temperature drops below 40°F. Circulators and burner turn off when the temperature rises above 48°F.
CIRCULATOR EXERCISING	<ul style="list-style-type: none"> For each circulator, select whether you want the control to automatically start the circulator and run for 10 seconds for each 72-hour period of inactivity.
0-10V PUMP OUTPUT	<ul style="list-style-type: none"> Enable or disable the 0-10 VDC output to be used for a 0-10 VDC variable speed boiler circulator. NOTE: The 0-10 VDC output can only be used with one function at a time. Enabling it for one will disable for the remainder.
VARIABLE SPEED MAX/MIN RATE VOLTS	<ul style="list-style-type: none"> Select the voltage required to be output when the boiler is at Max/Min Rate, respectively. The output will scale according to the bounds given. For inverse voltage curve pumps, Max can be set below Min. When using Manual Test Mode to set these parameters, force rate to High Fire to save the Variable Speed Max Rate Volts setting, and force rate to Low Fire to save the Variable Speed Min Rate Volts setting.
VOLTS WHEN BURNER OFF	<ul style="list-style-type: none"> Select the voltage required for the 0-10V boiler pump to run at when the boiler is servicing a call for heat, but does not need to fire its burner. The pump also runs at this voltage when the boiler is in Standby, Pre-pump, Pre-purge and Post-purge/Post-pump states. It will transition to mirroring rate based on Variable Speed Max/Min Rate Volts constraints and the actual blower speed when in Ignition Speed state and all burner-active states.

4

Screens shown on this page are typical only. Actual screens depend on control settings chosen.



NETWORK SETTINGS Menus

Figure 27 NETWORK SETTINGS options

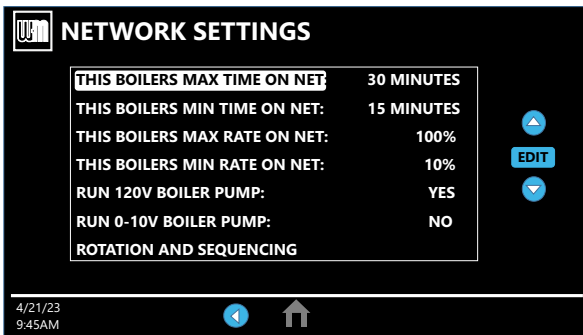
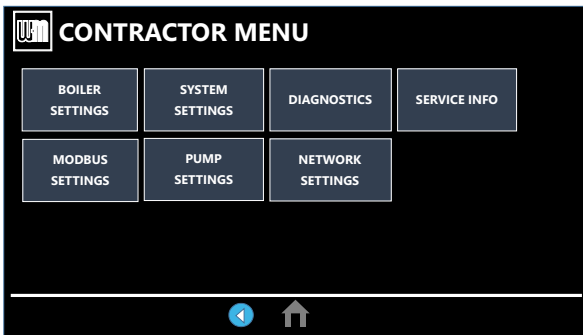

Menu Item	Purpose
THIS BOILERS MAX TIME ON NET	<ul style="list-style-type: none"> Maximum amount of time this boiler will operate on a network call for heat from the Master boiler before switching to a LOCAL PRIORITY 2 demand (if no LOCAL PRIORITY 1 demand is present).
THIS BOILERS MIN TIME ON NET	<ul style="list-style-type: none"> Minimum amount of time this boiler will operate on a network call for heat from the Master boiler before switching to a LOCAL PRIORITY 1 demand.
THIS BOILERS MAX RATE ON NET	<ul style="list-style-type: none"> Maximum rate the boiler will run at during NETWORK calls.
THIS BOILERS MIN RATE ON NET	<ul style="list-style-type: none"> Minimum rate the boiler will run at during NETWORK calls.
RUN 0-10V BOILER PUMP	<ul style="list-style-type: none"> Select whether or not to run a 0-10V variable speed boiler pump when this boiler runs network priorities. Can be used at the same time as 120V boiler pump.
RUN 120V BOILER PUMP	<ul style="list-style-type: none"> Select whether or not to run a 120V boiler pump when this boiler runs network priorities. Can be used at the same time as 0-10V boiler pump.
ROTATION & SEQUENCE	<ul style="list-style-type: none"> Select the method by which the boilers will turn on and off. Choose between SMART, PARALLEL, or SERIES (This setting is only accessible on Master boiler). See pages 75 to 76



ROTATION AND SEQUENCE

Figure 28 NETWORK SETTINGS options - Rotation and Sequence

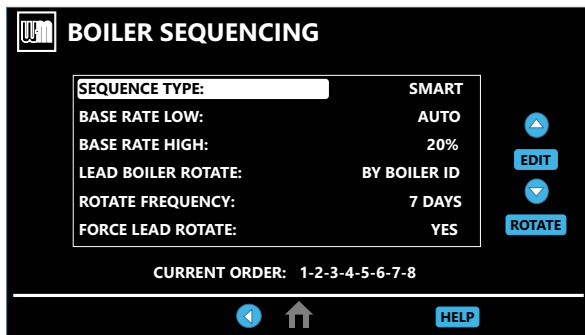
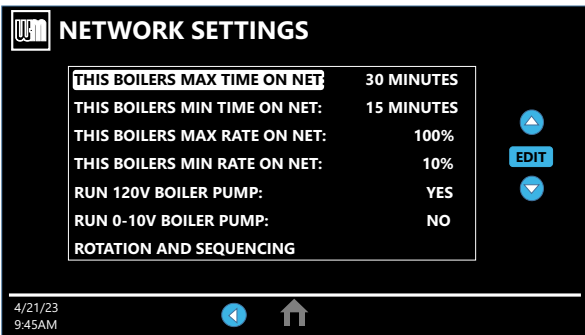
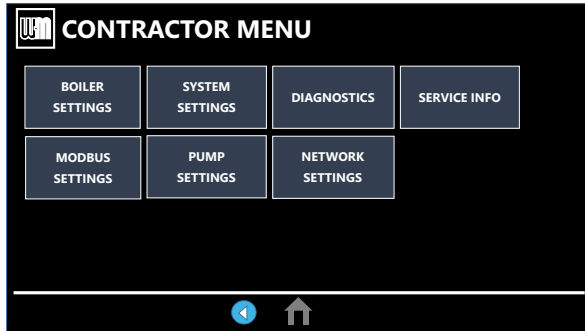

Menu Item	Purpose
SEQUENCE TYPE	<ul style="list-style-type: none"> Select the method the boilers will turn on and off. Choose between SERIES, PARALLEL, or SMART. Sequencing means the way in which boiler firing rate is controlled as boilers are turned on and off by the Master boiler. With the default settings, SMART SEQUENCING maximizes efficiency when adding boilers to the network. It runs more boilers to satisfy the demand. Boilers added start at the user-set Base Rate Low. With the default settings, PARALLEL SEQUENCING balances efficiency and number of boilers running. Each boiler modulates up to the user-set Base Rate High before adding another boiler. With the default settings, SERIES SEQUENCING minimizes the number of boilers running. Each boiler modulates to its Max Rate before adding another boiler.
BASE RATE HIGH	<ul style="list-style-type: none"> This sets highest modulation rate before turning on the next boiler. In SMART mode this valve is automatically calculated. See Figure 29, page 76 for more information.
BASE RATE LOW	<ul style="list-style-type: none"> This sets rate that the next boiler in sequence is going to turn on when called. In PARALLEL/SERIES mode this valve is automatically calculated. See Figure 29, page 76 for more information.
LEAD BOILER ROTATE	<ul style="list-style-type: none"> Choose how to rotate the boiler sequencing. Choose either OFF, BY BOILER ID, TOTAL HOURS, or INCREMENTAL HOURS. Firing sequence is changed every rotation period (ROTATE FREQUENCY – see setting explanation below). OFF — Master boiler is always the first to fire. Others fire in the order of their network ID. BY BOILER ID — Lead boiler toggles in the sequence of network ID numbers (changes from boiler number 1 to number 2, then boiler number 2 to number 3, etc.). TOTAL HOURS — The boiler with the most lifetime operating hours is moved to the last in the firing sequence. The boiler with the least lifetime operating hours is made first in the sequence. Others are ordered by their respective lifetime operating hours. INCREMENTAL HOURS — Firing sequence is based on the operating time during the previous rotation period. The boiler with the least operating time is started first; the boiler with the most operating time is started last; all others are started in order of their operating time.
ROTATE FREQUENCY	<ul style="list-style-type: none"> Recalculates the boiler order every ## days based on lead boiler rotate setting.
FORCE LEAD ROTATE	<ul style="list-style-type: none"> Select YES or NO. When the rotation frequency timer expires and the new order is calculated, this forces off the boiler lowest in the sequence. Then the boiler highest in the sequence fires to replace it.
CURRENT ORDER	<ul style="list-style-type: none"> Shows the current firing order of the boilers on the network. This list updates based on how many boilers are detected and the order of sequence based on the above settings. Sequence is shown as left-most boiler is first to turn on. Right-most boilers are the first to turn off.

Screens shown on this page are typical only. Actual screens depend on control settings chosen.





ROTATION AND SEQUENCE (continued)

Figure 29 Sequencing options — SMART, PARALLEL, or SERIES (examples shown for a 3-boiler network)

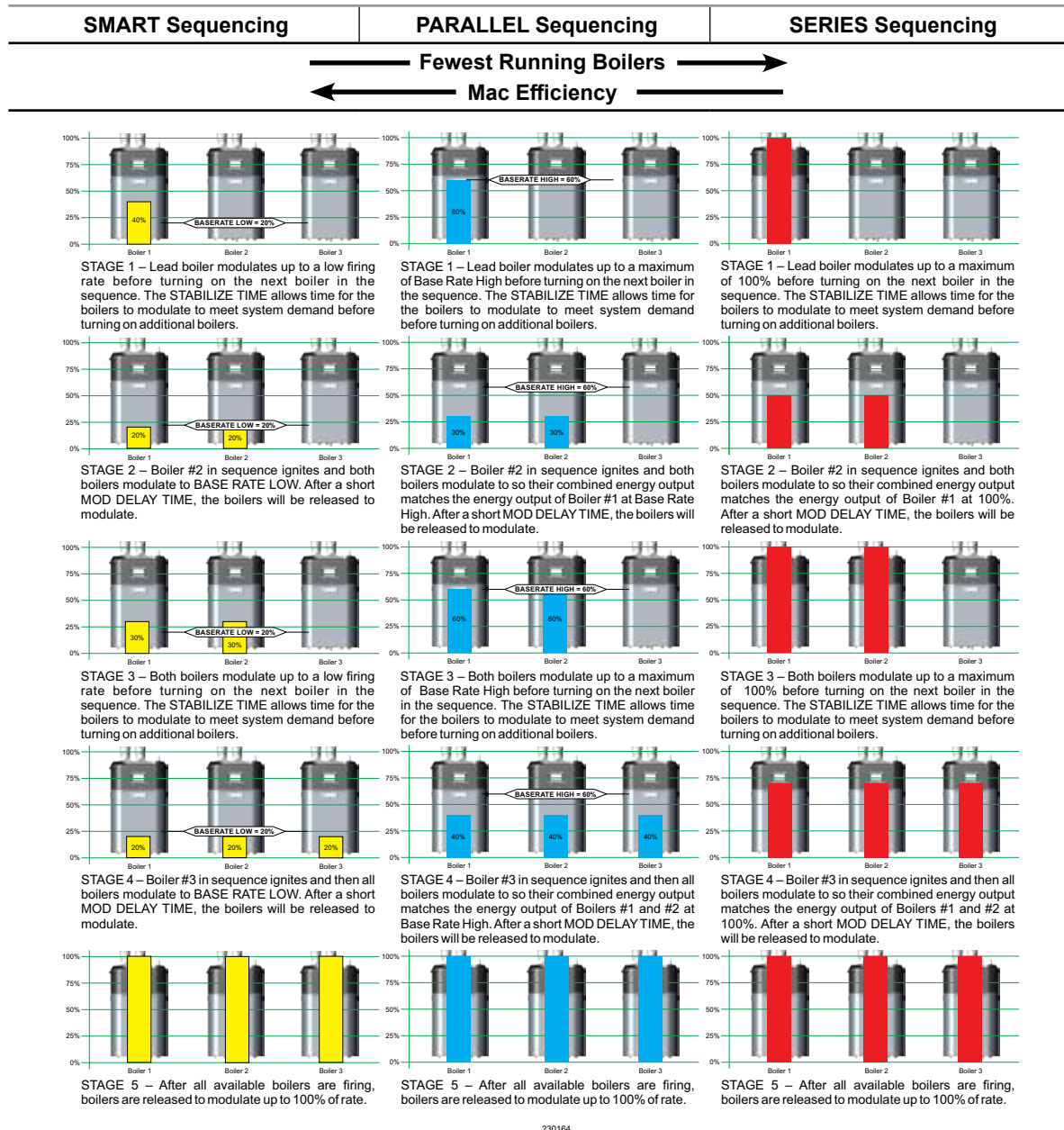

230164

Figure 30 Boiler sequencing, adding and dropping boilers

Control differential settings determine adding and dropping boilers

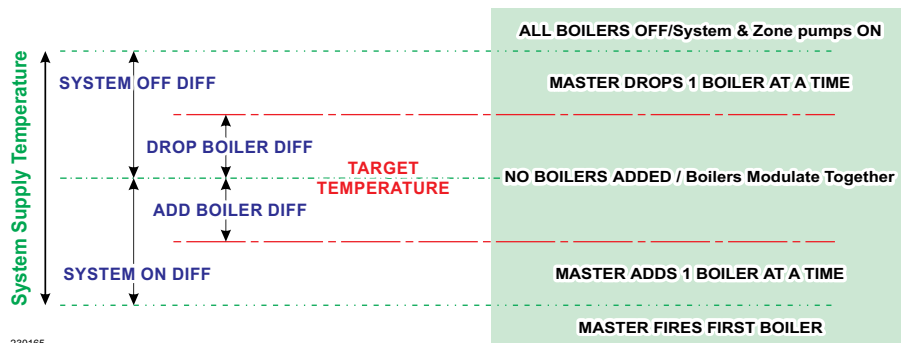

230165



SYSTEM SETTINGS Menus

System Settings Menu Navigation

1. Access contractor menus by pressing the WM Logo for seven seconds from the home screen.
2. Select SYSTEM SETTINGS on the screen.
3. See Figure 31 for an explanation of control settings.

Figure 31 SYSTEM SETTINGS options

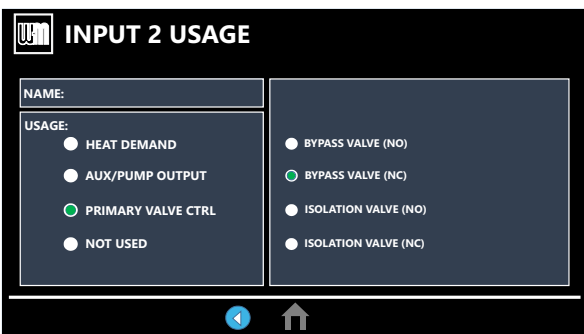
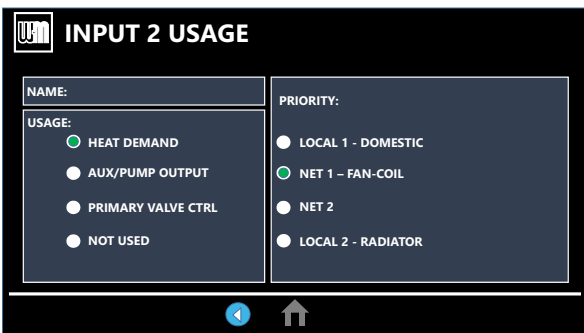
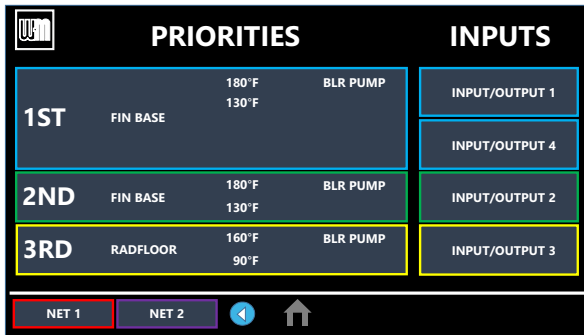
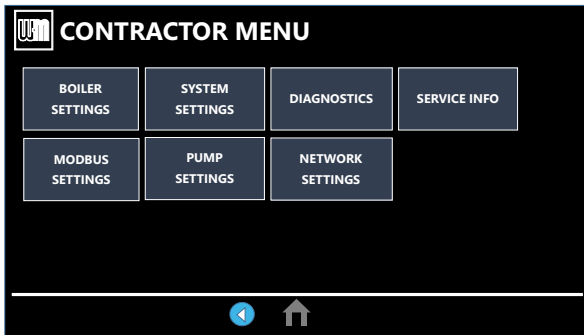

Menu Item	Purpose
INPUTS	<ul style="list-style-type: none"> • Press on any of the Input squares to navigate to the Input assignment screen. Assign priorities to inputs and the source of Input 2. • Custom name will appear above Input/output # when a name is entered.
PRIORITIES	<ul style="list-style-type: none"> • Press on any of the Priorities buttons to navigate to that priority settings. • Each box displays from left to right: the priority number, system type, Max Target Temp on top of Min Target Temp (when used), and populates BLR Pump and/or SYS PUMP when selected to run these during that priority. The color of the box corresponds to the color of the Input/output #. • See page 78 (Boiler Priority menus).

Menu Item	Purpose
NAME	<ul style="list-style-type: none"> • Give a name to the input/output you are assigning to help clarify the use of this priority for future reference.
USAGE	<ul style="list-style-type: none"> • Assign whether the input is used for a Heat Demand, Aux/pump output, Primary Valve Control, or not used.
PRIORITIES	<ul style="list-style-type: none"> • Assign which priority this input is linked to.

Screens shown on these pages are typical only. Actual screens depend on control settings chosen.



Boiler PRIORITY Menus

Figure 32 Boiler PRIORITY options

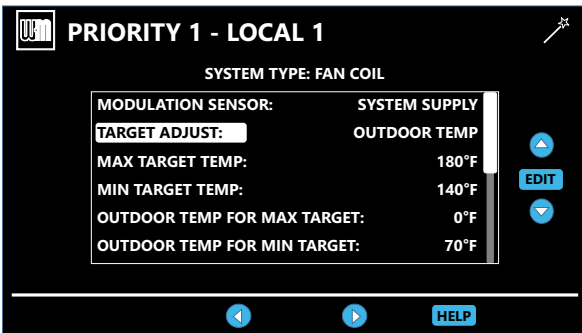
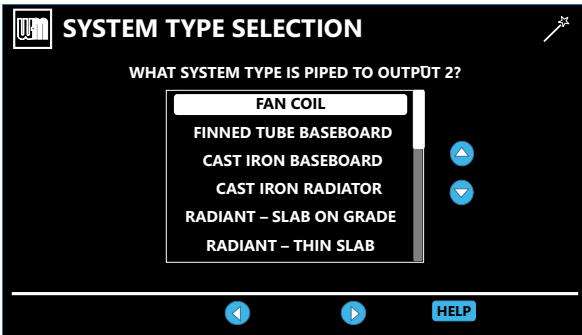
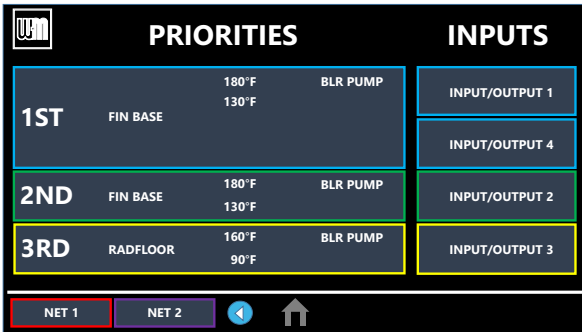

Menu Item	Purpose
SYSTEM TYPE	<ul style="list-style-type: none"> Select the system type for this PRIORITY, based on the heat emitter type(s) in the system. Use the CUSTOM selection to set the control for a different system type. The factory preset values for Max Target Temp, MIN TARGET TEMP, Outdoor Temp for Min Target and OUTDOOR TEMP FOR MAX TARGET are chosen based on the normal best setting for the terminal units.
TARGET MODULATION SENSOR	<ul style="list-style-type: none"> Choose SYSTEM SUPPLY or BOILER OUT to determine which will be the primary temperature sensor. The control will modulate boiler input to reach the TARGET temperature. (Default is SYSTEM SUPPLY only if sensor is attached.) If system sensors are not used, boiler defaults to using boiler outlet sensor in place of system sensor.
TARGET ADJUST	<ul style="list-style-type: none"> Select how target temperature is calculated by control: NONE (no reset, fixed target temperature), 0-10V (target temperature based on analog input from remote source), Outdoor Temp (outdoor reset operation; default setting when an outdoor temperature sensor is attached).
MAX TARGET TEMP	<ul style="list-style-type: none"> Set Max Target Temp to the required supply water temperature for the system at design maximum heat loss (typically 180°F for finned tube baseboard on new installations.)
MIN TARGET TEMP	<ul style="list-style-type: none"> MIN TARGET TEMP should equal the desired minimum supply water temperature for the system. This line is not shown on priorities configured as DHW system type or Heating system type, if outdoor temperature sensor not used.
OUTDOOR TEMP FOR MAX TARGET	<ul style="list-style-type: none"> OUTDOOR TEMP FOR MAX TARGET means the outdoor temperature at which the target temperature reaches its maximum value (MAX TARGET TEMP). OUTDOOR TEMP FOR MAX TARGET should equal the Outdoor Temp (outdoor design temperature) for the installation's location. This line is not shown on priorities configured as DHW system type or Heating system type, if outdoor temperature sensor not used.
OUTDOOR TEMP FOR MIN TARGET	<ul style="list-style-type: none"> OUTDOOR TEMP FOR MIN TARGET is the outdoor temperature at which the target temperature reaches its minimum (MIN TARGET TEMP). This line is not shown on priorities configured as DHW system type or Heating system type, if outdoor temperature sensor not used.
VOLTAGE FOR MAX TARGET	<ul style="list-style-type: none"> Only appears if Target Adjust or Source for Input 2 is set to 0-10V. For Target Adjust, this sets the voltage at which Max Target Temp temperature is requested. For Source on Input 2, this sets the voltage that corresponds to Max Rate.
VOLTAGE FOR MIN TARGET	<ul style="list-style-type: none"> Only appears if Target Adjust or Source for Input 2 is set to 0-10V. For Target Adjust, this sets the voltage at which Min Target Temp temperature is requested. For Source on Input 2, this sets the voltage that corresponds to Min Rate.

4



Boiler PRIORITY Menus (continued)

Figure 33 Boiler PRIORITY options 2

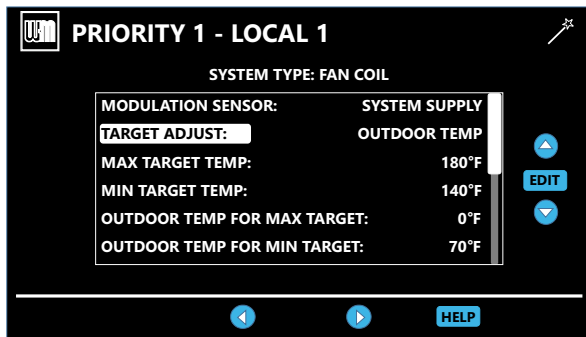
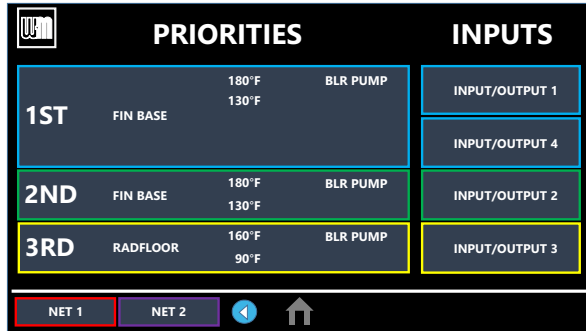

Menu Item	Purpose
COLD START ERROR	<ul style="list-style-type: none"> At ignition, the difference between the Target temperature and the current temperature is compared to this value to decide the starting modulation rate once released to modulation. If the difference is less than or equal to this value the modulation rate will start at Min Rate. If it is greater than this value, the control will calculate a higher modulation starting rate.
TARGET BOOST TIME	<ul style="list-style-type: none"> Every time the call for heat surpasses this duration of time the target temp will increase (boost) up 10°F to a maximum temperature of MAX TARGET TEMP.
SYSTEM ON DIFF	<ul style="list-style-type: none"> This is the amount the temperature must drop below system target to begin network modulation routine. (This line may NOT appear, depending on TARGET ADJUST setting.)
SYSTEM OFF DIFF	<ul style="list-style-type: none"> This is the amount the temperature must rise above system target to turn the boiler OFF.
MAX BLR TEMP	<ul style="list-style-type: none"> If the boiler outlet temperature approaches [Max Boiler Temp – Boiler On Diff] before the system supply temperature reaches its target, the control will modulate the boiler based on the boiler outlet temperature. The boiler will cycle and modulate based on the boiler ON and OFF differential settings. (This line does NOT appear if Target Mod Sensor is set to Boiler Out).
BOILER ON DIFF	<ul style="list-style-type: none"> This is the amount the temperature must drop below target (or Boiler Max) to turn the boiler ON.
BOILER OFF DIFF	<ul style="list-style-type: none"> This is the amount the temperature must rise above target (or Boiler Max) to turn the boiler OFF.
MAX ON TIME	<ul style="list-style-type: none"> Maximum time boiler will run on this priority if it is being asked to run on another priority. Will rotate among all priorities its being asked to run. Network boilers are also controlled by NET MAX ON TIME . NETWORK PRIORITY 1 only — Maximum time master will operate the network on network priority 1 if network priority 2 is calling for heat. When the master boiler detects a local call for heat from any boiler that is currently operating for a network demand, the master control will allow that boiler to switch to its local priority and replace the lost network energy of that boiler appropriately.
MIN ON TIME	<ul style="list-style-type: none"> Minimum time the boiler will run on an existing priority before switching to a lower priority, or back to an existing higher priority. If a new higher priority is called during MIN ON TIME, the boiler will immediately switch to actively heat the higher priority. Network boilers are also controlled by NET MIN ON TIME. NETWORK PRIORITY 2 only — Minimum time master will operate on a network priority 2 if network priority 1 is calling for heat.

4

Screens shown on this page are typical only. Actual screens depend on control settings chosen.



Boiler PRIORITY Menus (continued)

Figure 34 Boiler PRIORITY options 3

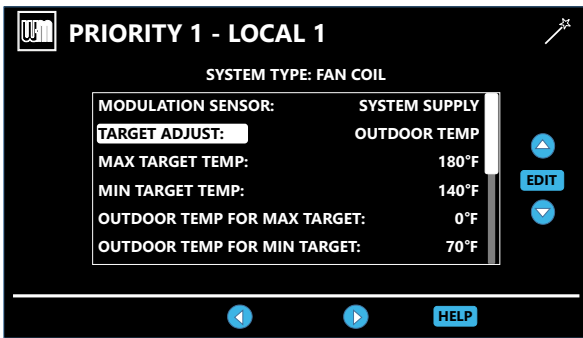
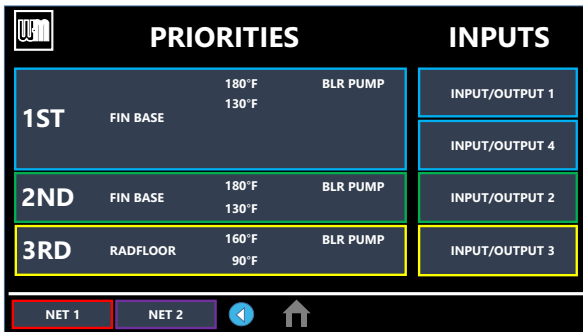

Menu Item	Purpose
RUN 0-10V BOILER PUMP	<ul style="list-style-type: none"> The 0-10 VDC output will energize to run a variable speed boiler pump when selected.
RUN 120V BOILER PUMP	<ul style="list-style-type: none"> Selects whether the 120V Boiler Pump is turned on while running on this priority. Located here for single boilers. Located in the Network Settings screen for Master/Shadow boilers.
RUN AUX PUMP/OUTPUT	<ul style="list-style-type: none"> When set to YES, input/output pairs on any network boiler assigned as AUX PUMP/ OUTPUT -> ANY TT INPUT BY ITS PRIORITY, will activate. Set this to NO for priorities that do not need this AUX PUMP/ OUTPUT to be active.
PRE PUMP	<ul style="list-style-type: none"> Time associated PUMPS and AUX PUMP/ OUTPUT are run before entering prepurge.
POST PUMP	<ul style="list-style-type: none"> Time associated PUMPS and AUX PUMP/ OUTPUT are run after the call for heat has ended and before switching to another call for heat.
MAX SYS BTUs	<ul style="list-style-type: none"> Limits the energy allowed by the boiler network to be put into this priority's system. The default is set to AUTO (the sum of all network boiler sizes). If the total size of the boiler network is too large for a system, adjust MAX SYS MBH lower to the appropriate energy. MAX SYS MBH can be set greater than AUTO if more boilers are planned to be installed to the same network. This setting can be adjusted in 100 MBH increments (100 MBH = 100,000 BTU/hours).
MIN BOILERS	<ul style="list-style-type: none"> The Master turns on this many boilers in the network on an initial call for heat in order to avoid delays due to accumulative wait times between boilers. When switching to another network priority, MIN BOILERS is re-evaluated based on the other priority's setting.
MAX RATE	<ul style="list-style-type: none"> Maximum rate this boiler will modulate up to while running on this priority. These are only adjustable for single/local priorities, and network boiler rates should be adjusted in the Network Settings menu.
MIN RATE	<ul style="list-style-type: none"> Minimum rate this boiler will modulate down to while running on this priority. These are only adjustable for single/local priorities, and network boiler rates should be adjusted in the Network Settings menu.

4



Boiler PRIORITY Menus (continued)

Figure 35 Boiler PRIORITY options 4

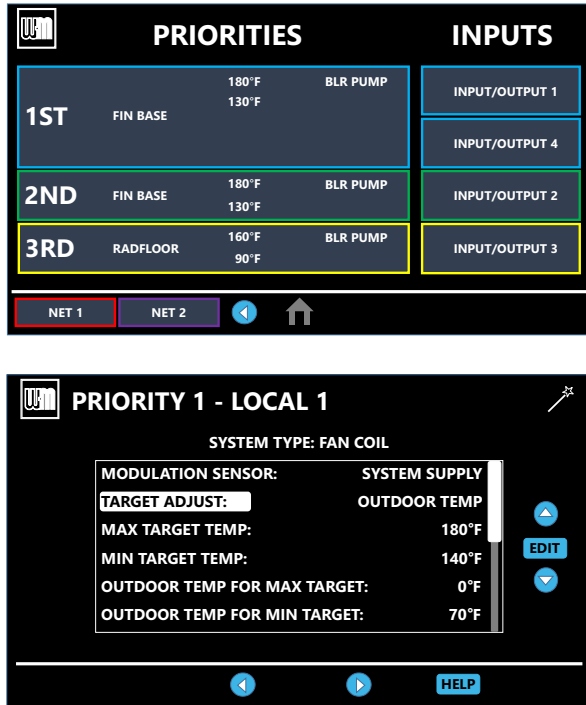

Menu Item	Purpose
ADD'L HEAT DEMAND ACTIVATE CONTACT	<ul style="list-style-type: none"> If this is set to 1st: Immediately on a call for heat, the heat demand contacts close and the RESPONSE TIME timer starts. If the call for heat from this demand is still active at the end of the Response Time and the system has not reached [Target Temp - System On Diff], the boiler system will start. If the system temperature is within this range, the boiler system will not start unless the temperature drops below this value. The Add'l Heat Demand contact opens when the heat demand turns off. If this is set to 2nd: The boiler system immediately starts a call for heat and the RESPONSE TIME timer. If the call for heat is still active when the RESPONSE TIME expires, the boiler will close its additional heat demand contact. If this set to ODT: The boiler system will start based on the Outdoor Temperature, the activate contact below and above setpoint and the Outdoor Temp setpoint valve. Timers reset when priorities are switched. NETWORK PRIORITY 1 or 2 — The additional heat demand must be wired to the master boiler. LOCAL PRIORITY 1 or 2 — The additional heat demand must be wired to the individual boiler. A master boiler cannot use additional heat demand on a local priority.
RESPONSE TIME	<ul style="list-style-type: none"> Time to wait for system to respond before taking the Activate Contact action. If ACTIVATE CONTACT is OFF, this line does not appear.
TEMP DEPENDENT	<ul style="list-style-type: none"> Selecting YES will require the System Supply Temperature to be below the Target temperature before it will activate the Additional Heat Demand contacts. Selecting YES will also activate the 0-10V output along side the contacts. Selecting NO will disregard System Supply Temperature and activate AHD contacts strictly according to the Activate Contact setting. NOTE: If no valid System Supply and Return sensor pair are detected the Temp Dependent YES setting cannot be used and the contact will be disabled until a valid sensor pair is detected.
OUTDOOR TEMPERATURE SETPOINT	<ul style="list-style-type: none"> Selecting the outdoor temperature valve to be used in conjunction with the Activate Contact Below/Above Setpoint setting. NOTE: A valid outdoor temperature sensor must be detected to use this feature. If one is not detected, this feature will be temporarily disabled until one is found.
ACTIVATE CONTACT BELOW SETPOINT	<ul style="list-style-type: none"> Select 1st to activate the contact before the boiler when below the Outdoor Temperature Setpoint and after the boiler when above. Select 2nd to activate the contact in reverse order. Select OFF to disable the output when below the setpoint.
ACTIVATE CONTACT ABOVE SETPOINT	<ul style="list-style-type: none"> Select 1st to activate the contact before the boiler when above the Outdoor Temperature Setpoint and after the boiler when below. Select 2nd to activate the contact in reverse order. Select OFF to disable the output when above the setpoint.
MAX RATE VOLTAGE	<ul style="list-style-type: none"> When blower modulation is at maximum the control will output this voltage from 0-10V output when using Additional Heat Demand.
MIN RATE VOLTAGE	<ul style="list-style-type: none"> When blower modulation is at minimum, the control will output this voltage from 0-10V output when using Additional Heat Demand.





AUX Pump/Output

Table 11 Aux Pump/Output operation

Option	Activation Conditions	Suggested Uses
ALWAYS ON	<ul style="list-style-type: none"> Output is always energized whenever the control is powered. 	<ul style="list-style-type: none"> Hot loop for seasonal boilers that are manually shut down at end of season and started up at start of heating season.
EXTERNAL SWITCH	<ul style="list-style-type: none"> The output is energized on closure of an external switch wired to this input and is de-energized when the external switch opens. 	<ul style="list-style-type: none"> Hot loop for boilers whose CH is manually shut down at end of season and started up at start of heating season, but remain available for local calls (such as DHW).
OUTDOOR BELOW WWSD	<ul style="list-style-type: none"> This output is energized only when outdoor temperature is below the WWSD setting (see BOILER SETTINGS menu). This setting is non-selectable if WWSD is set to OFF or Outdoor Temp is not connected at initial boiler power. If Outdoor Below WWSD is already chosen and WWSD is later set to OFF, Outdoor Below WWSD will behave as Always On. 	<ul style="list-style-type: none"> Hot loop for boilers whose CH is automatically shut down based on outdoor temperature (inferred heat loss), but remain on for local calls (such as DHW).
ANY INPUT	<ul style="list-style-type: none"> The assigned output is energized if there is an input closure on this boiler. The assigned output will de-energize once there are; no input on this boiler, post-purge has finished and post-pump time has expired. If the closed input is configured for a heat demand, its output will de-energize after post-purge and post-pump. 	<ul style="list-style-type: none"> Energize a system pump relay if pump must run during all heating calls.
INPUT PRIORITY SETTINGS	<ul style="list-style-type: none"> The assigned output is energized if both of the following are true: <ol style="list-style-type: none"> There is an input closure on this boiler. RUN AUX PUMP/OUTPUT is set to YES for the priority assigned to the closed input. The assigned output will de-energize once there are no input closures on any of the network boilers, post-purge has finished, and post-pump time has expired. 	<ul style="list-style-type: none"> Energize a system pump relay if pump must run only on some heat calls (such as systems with locally-connected DHW heating).
SYSTEM DAMPER	<ul style="list-style-type: none"> The assigned output is energized when the boiler receives a call for heat and starts to pre-purge. The assigned output is de-energized once the burner is off and post-purge is complete. Energizes any time any boiler on the network receives a heating demand or AHD is activated. 	<ul style="list-style-type: none"> Use for interlocking with combustion air damper, flow switch, etc., when more than one boiler is connected/piped to one device
LOCAL DAMPER	<ul style="list-style-type: none"> The assigned output is de-energized once the burner is off and post-purge is complete. Only activates if this boiler is attempting to fire. 	<ul style="list-style-type: none"> Use for interlocking with combustion air damper, flow switch, etc., per individual boiler, separately operated from the remaining boilers in the system.

Table 12 System/Local Damper operation — start, run, and stop based on boiler status

Option	Standby	TT Closed	Pre-pump	Pre-purge	Burner Running	Post-purge	Post-pump	Standby	Comments
ANY INPUT OR INPUT PRIORITY SETTINGS	OFF	ON	→					OFF	<ul style="list-style-type: none"> See Table 11 for explanation of differences between the input options.
SYSTEM/ LOCAL DAMPER	OFF	OFF	OFF	ON	→		OFF	OFF	—



Primary Valve Control

Figure 36 Primary Valve Control options

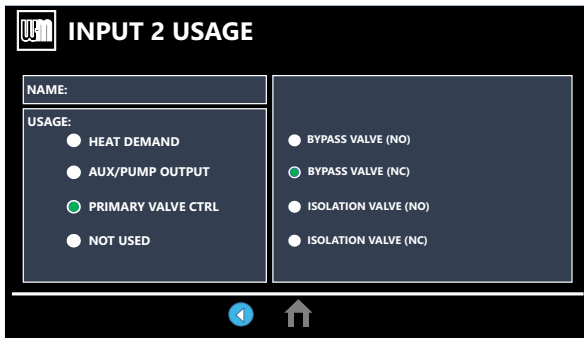
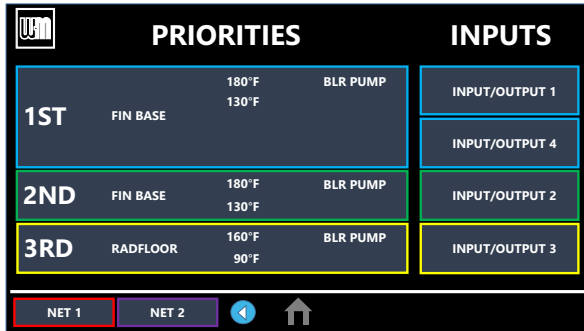

Menu Item	Purpose
OPERATION	<ul style="list-style-type: none"> When the boiler is in Standby with no calls for heat, or when no Network priority calls are active, the bypass valve options will actuate such that they will be open for flow. When a boiler receives a Network priority call for heat, the bypass valve will close and the isolation valve for the boilers that wish to run will actuate open to allow flow through the boiler. The lead boiler will also activate its boiler pump options that are selected to Yes, if applicable. Each subsequent boiler will actuate its isolation valves as they are requested to run by the Master boiler. It is possible to use an output to power a valve one direction and another to power it the opposite direction, for valves that are Power Open and Power Closed. NOTE: bypass and isolation valves do not respond to a LOCAL priority call for heat. Bypass and Isolation Valve functionality are Network priority operations ONLY.
BYPASS VALVE (NO)	<ul style="list-style-type: none"> Select this option for Bypass Valves that are Normally Open and must be POWERED CLOSED. NOTE: If the Bypass Valve fails, it will open, allowing flow. Choose the NO/NC option that best fits your installation.
BYPASS VALVE (NC)	<ul style="list-style-type: none"> Select this option for Bypass Valves that are Normally Closed and must be POWERED OPEN. The output will be in a powered state during Standby with no active Network priorities. NOTE: If the Bypass Valve fails, it will close, disallowing flow. Choose the NO/NC option that best fits your installation.
ISOLATION VALVE (NO)	<ul style="list-style-type: none"> Select this option for Isolation Valves that are Normally OPEN and must be POWERED CLOSED. The output will be in a powered state during Standby with no active Network priorities. NOTE: If the Bypass Valve fails, it will OPEN, allowing flow through the boiler. Choose the NO/NC option that best fits your installation.
ISOLATION VALVE (NC)	<ul style="list-style-type: none"> Select this option for Isolation Valves that are Normally CLOSED and must be POWERED OPEN. NOTE: If the Bypass Valve fails, it will CLOSE, disallowing flow through the boiler. Choose the NO/NC option that best fits your installation.

4

Screens shown on this page are typical only. Actual screens depend on control settings chosen.



DIAGNOSTICS Menu

Table 13 DIAGNOSTICS menu

Menu/Item	Comment
Temperatures	
Status	Current operating status of the boiler. Prepurge, Ignition, Name of the system Type being satisfied, post purge, Warm Weather Shut down, Trouble
Boiler Out1	Temperature of the first sensing element of the boiler's heat exchanger outlet sensor
Boiler Out2	Temperature of the second sensing element of the boiler's heat exchanger outlet sensor
Boiler In	Temperature of the boiler's heat exchanger inlet sensor
System Supply	Temperature of the system water after the boiler loop
System Return	Temperature of the system water returning to the boiler loop
Flue1	Temperature of the first sensing element of the boiler's flue gas sensor
Flue2	Temperature of the second sensing element of the boiler's flue gas sensor
Outdoor	Temperature of the remote outdoor air temperature sensor
Target Temperature	Current target temperature of the active priority.
Inputs	
Status	Current operating status of the boiler. Prepurge, Ignition, Name of the system Type being satisfied, post purge, Warm Weather Shut down, Trouble
Input 1	Call for heat status on Input 1
Input 2	Call for heat status on Input 2 (Input 2 can be TT1 or 0-10 VDC input)
Input 3	Call for heat status on Input 3
Input 4	Call for heat status on Input 4
0-10V Input	Voltage input for target adjust or modulation
Manual Limit	External manual limit on low voltage terminal strip
Auto Limit	External auto limit on low voltage terminal strip
Low Wtr Cutoff	Low water cutoff device (integrated in the Boiler Out sensor)
Air P-Switch	Limit device (inside boiler jacket) that will shut off the boiler if flue pressure becomes too high
Closure Switch	J18 jumper circuit closed or open (flow switch, CAD, etc.)
Blower Speed	Feedback from blower
Flame Signal	Number indicating the presence and quality of the flame used to shut down or boost the boiler
Outputs	
Status	Current operating status of the boiler. Prepurge, Ignition, Name of the system Type being satisfied, post purge, Warm Weather Shut down, Trouble
Gas Valve	Control's gas valve circuit status
Circulator 1	Control's circulator 1 relay status
Circulator 2	Control's circulator 2 relay status
Circulator 3	Control's circulator 3 relay status
Circulator 4	Control's circulator 4 relay status
Boiler Circ	Boiler's circulator
120V Boiler Pump	Used to control the boiler's 120V Boiler Pump power
0-10V Output	0-10V output signal used for external device or variable speed boiler pump
Blower Signal	Control's signal controlling the blower speed
Additional Heat Demand	Additional heat demand contact status
Alarm	Alarm contact status

4



DIAGNOSTICS Menu (continued)

Menu/Item	Comment
Run Times	
Burner Time	Displays cumulative time the burner has been active (can be increased by user)
Input 1 Time	Displays cumulative time that Input 1 has been closed
Input 2 Time	Displays cumulative time that Input 2 has been closed (Or 0-10V \geq 1 volt)
Input 3 Time	Displays cumulative time that Input 3 has been closed
Input 4 Time	Displays cumulative time that Input 4 has been closed
Ignition Count:	Displays total number of successful ignitions
Last 5 Proof of Ignition:	Displays last 5 Proof of Ignition flame valves read by the control
Last 5 Stabilization:	Displays last 5 Stabilization flame valves read by the control
Last Factory Reset:	Shows the time/date stamp of the of the last factory reset performed
Last Power Cycle:	Shows the time/date stamp of the last known power cycle
TO RESET ALL HISTORY COUNTERS TO ZERO:	
To reset all history counters to zero: Enter the FAULT HISTORY menu, then press the reset button. This will cause ALL history to be deleted. To maintain history, set counters individually.	
Fault History	
Ignition Retries	Displays cumulative ignition attempts. It is recommended that his be reset during yearly maintenance by selecting this line and pressing the Reset button
Manual Reset Cnt	Displays number of manual reset lockouts since last cleared
Auto Reset Cnt	Displays number of auto reset lockouts since last cleared
Lockout History 1 - 6	Choose this to view the second most recent error recorded
Fault Type	Displays the type of fault that occurred
Time	Displays time that lockout occurred
Date	Displays date that lockout occurred
Status	Displays what the status of the boiler was at the time of the error
Temperatures	Choose this to view the Boiler Temperatures at the time of the error
Inputs	Choose this to view the status of the Boiler Inputs at the time of the error
Outputs	Choose this to view the status of the Boiler Outputs at the time of the error
Manual Test Mode	
Status	Current operating status of the boiler. Prepurge, Ignition, Name of the system Type being satisfied, post purge, Warm Weather Shut down, Trouble
Inputs	Displays which inputs are presently calling for heat
Target Temp	Calculated target temperature based on outdoor temp or the max target if no ODR
Modulation	Displays what sensor the boiler is using to modulate from. May also indicate reason for boiler rate self-limiting.
Boiler Out	Temperature of the outlet sensor on the boiler heat exchanger
Boiler In	Temperature of the inlet sensor on the boiler heat exchanger
System Supply	Temperature of the system water after the boiler loop
System Return	Temperature of the system water returning to the boiler loop
Flue	Temperature of flue gases
Outdoor	Temperature of outdoor air
Blower Signal	Control's signal controlling the blower speed
0-10V Output	0-10V output signal used for external device or variable speed boiler pump
Blower Speed	Blower's feedback to the control
Flame Signal	Number indicating the presence and quality of the flame used to shut down or boost the boiler
Force Rate	Used to manually force a rate during a call for heat. Choose auto for normal operation
Manual Reset	
Reset selected condition	



SERVICE Menus

Table 14 SERVICE menus navigation

Service Info	Comment
Name	Contractor name to appear in maintenance reminders and during lockouts
Phone	Contractor phone number
Model	Displays the boiler model selected in the boiler setup
CP Number	Enter the CP# of the boiler
Installed	Enter the date the boiler was installed
Last Maintenance Performed	Date automatically entered when Reset Reminder is chosen by contractor
Next Maintenance Due	Date automatically calculated when Reset Reminder is selected by contractor
Interval Settings	Contractor selects maintenance reminder frequency based on service history
Reset Reminder	Contractor selects this to update Last maintenance Date and Next Date. Homeowner uses this to ignore the reminder and update only the Next Date.
Last Calibration Date	Displays date of last calibration performed.

SERVICE INFO

Use this section to enter contractor's information, Consumer Protection (CP) number, install date and to enter an automatic notice for maintenance (default is 12 months). Because this shows on the display, it is an automatic means of notifying the homeowner of need for scheduled maintenance by the technician. Select RESET REMINDER to reset for the next maintenance date.

Additional Instructions

For all additional instructions for startup, operation, and maintenance of the boiler, refer to the Evergreen® Pro Series 2 Boiler Manual (part number 550-100-579).

