

# SCHEMATIC WIRING DIAGRAM

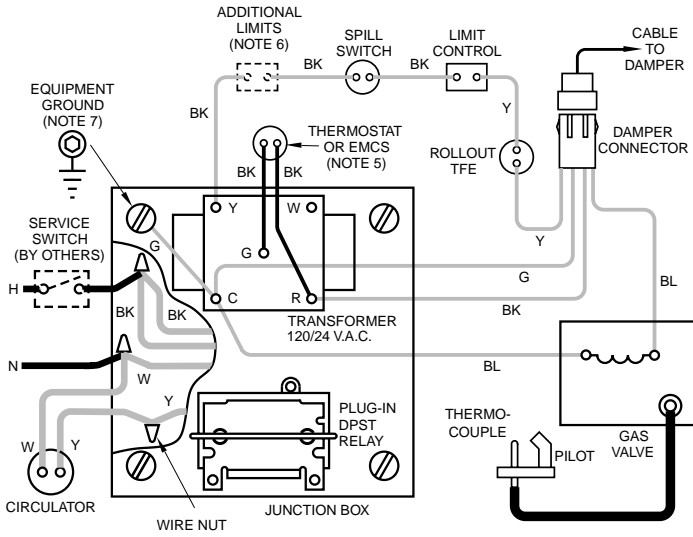

**WARNING** ELECTRICAL SHOCK HAZARD, CAN CAUSE SEVERE INJURY OR DEATH. DISCONNECT POWER BEFORE INSTALLING AND/OR SERVICING.

- NOTES:
- ALL WIRING MUST BE INSTALLED IN ACCORDANCE WITH:
    - U.S.A. - NATIONAL ELECTRICAL CODE AND ANY OTHER NATIONAL, STATE OR LOCAL CODE REQUIREMENTS.
    - CANADA - C.S.A. C22.1 CANADIAN ELECTRICAL CODE PART 1 AND ANY OTHER NATIONAL, PROVINCIAL OR LOCAL CODE REQUIREMENTS.
  - ALL CONTACTS SHOWN WITHOUT POWER APPLIED-OFF SHELF CONDITION.
  - IF ORIGINAL ROLLOUT TFE WIRE AS SUPPLIED WITH THE APPLIANCE MUST BE REPLACED, TYPE 200°C WIRE OR ITS EQUIVALENT MUST BE USED, IF OTHER ORIGINAL WIRE AS SUPPLIED WITH THE APPLIANCE MUST BE REPLACED, TYPE 105 °C OR ITS EQUIVALENT MUST BE USED.
  - REFER TO CONTROL COMPONENT INSTRUCTIONS PACKED WITH BOILER FOR APPLICATION INFORMATION.
  - THERMOSTAT - FOR SINGLE ZONE SYSTEMS, THERMOSTAT ANTICIPATOR SETTING IS 0.40 AMPS. FOR MULTIPLE ZONE SYSTEMS USING ZONE VALVES OR CIRCULATORS, REFER TO COMPONENT MANUFACTURER'S INSTRUCTIONS FOR APPLICATION WIRING AND THERMOSTAT ANTICIPATOR SETTING.  
EMCS - FOR EMCS CONNECTION IN PLACE OF THERMOSTAT, REFER TO EMCS INSTALLATION/OPERATING MANUAL.
  - L.W.C.O., ADDITIONAL HIGH LIMIT, ETC., WIRED IN SERIES.
  - ⊕ DENOTES FIELD INSTALLED CHASSIS GROUND.

# LADDER WIRING DIAGRAM

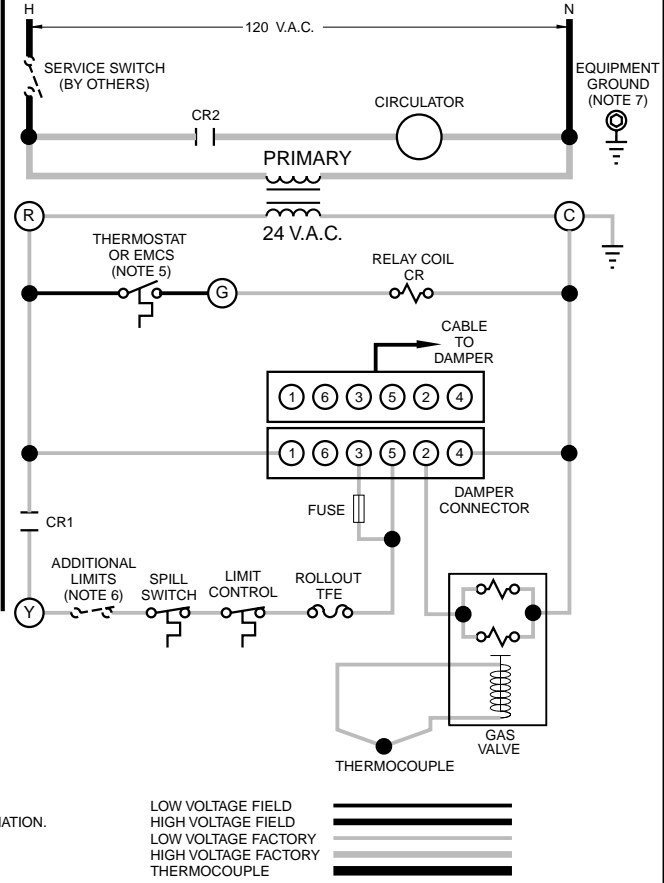

LOW VOLTAGE FIELD  
HIGH VOLTAGE FIELD  
LOW VOLTAGE FACTORY  
HIGH VOLTAGE FACTORY  
THERMOCOUPLE

**CGa**  
25 thru 8

- Standing Pilot
- Natural Or Propane Gas
- Forced Hot Water

**Wm WEIL-McLAIN**  
A United Dominion Company

Weil-McLain • 500 Blaine St. • Michigan City, IN 46360-2388

PART NUMBER **550-225-009/0999**