

Ultra

Gas-Fired Water Boiler

Conversion Instructions Altitudes over 5500 feet

Ultra -80, -105, -155, -230, & -310

Verify kit contents:

- High altitude propane orifices (use only for propane boilers)

Tools required:

- Phillips screwdriver
- Pipe wrenches or channel lock pliers
- T25 TORX wrench
- 5/32 long-handled Allen wrench

STOP! Read before proceeding:

WARNING

These instructions must only be used by a qualified installer/service technician. Read completely before beginning the conversion. Failure to follow all instructions can cause severe personal injury, death or substantial property damage.

WARNING

Turn off gas supply and electricity before beginning conversion. If boiler is hot from operation, allow time to cool before proceeding. Failure to do so can cause severe personal injury, death or substantial property damage.

NOTICE

After making changes to parameters, record the changes made and leave a copy with the boiler for future reference.

Additional instructions for PROPANE gas installations

WARNING

Ultra boilers are shipped ready to fire natural gas ONLY. (Exception: Ultra-80LP boilers are propane-ready.) You must install the high altitude propane orifice supplied in the High Altitude Kit if the boiler will be connected to propane. Follow all instructions in this document, the Propane Conversion Instructions and the Boiler Manual. **Note that Ultra-80NG, Ultra -310NG only and Ultra -310 Series 1 boilers also require a burner change for propane firing, as shown in the gas conversion instructions.**

DO NOT install the sea level orifice supplied in the propane conversion kit — use the orifice specified below. Failure to comply could result in severe personal injury, death or substantial property damage.

The high altitude propane gas orifice is located in the High Altitude Kit orifice bag. Install **ONLY** the orifice marked with the correct boiler size as shown below.

<u>Boiler Model</u>	<u>Propane Orifice Stamping</u>
Ultra -80	80-HA
Ultra -105	105-HA
Ultra -155	155-HA
Ultra -230	230-HA
Ultra -310	310-HA

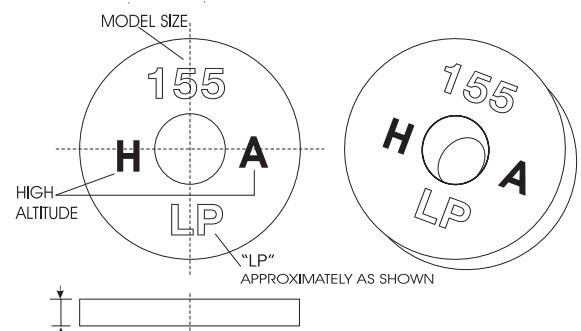

Reprogram control module – Natural gas and propane boilers

- Minimum fan speed (parameter 17) and ignition fan speed (parameter 19) **MUST** be changed for operation at altitudes over 5,500 feet.
- Change these parameters using following instructions, or load the correct high altitude parameter file from the Ultra Interface Kit CD. If using Gascom software to revise the parameters, use **ONLY** the values given in Table 1.

With the six buttons on the front of the boiler and the proper code, the boiler can be modified using the digital display (Figure 1). Perform the following steps with the boiler powered and in a standby condition.

- On the boiler display in [STBY] mode, press and hold the **STEP** button. While holding the "Step" button press and hold the **MODE** button. Hold both buttons together for several seconds until "Code" is displayed. Release buttons. "Code" stays on the display.

NOTE: If [CODE] is not displayed after several seconds release the buttons and press the **MODE** button several times to return to [STBY]. Repeat step two again.

- Press the **STEP** button once.
- Adjust the number displayed to [C - 05] by using the **+** and **-** buttons.
- Press the "Store" button.

NOTICE The Ultra control module will automatically exit code mode after 10 minutes of no activity.

- Press the mode button several times until [PARA] is displayed.
- Press the **STEP** button several times until [P-XX] is displayed. The XX represents the parameter that will be changed. The parameter's value will then be displayed.
- Use the **+** or **-** buttons to adjust to the desired value.

WARNING Do not set the value of parameters 17 or 19 higher than the values in Table 1.

- Press the **STORE** button. Steps 8 through 10 can now be repeated for additional parameter changes. Or continue to step 11 to exit.
- Press the **MODE** button until [STBY] is displayed to exit.

Figure 1 Ultra boiler digital display



	Mode button	
		Code not entered
Default:	Standby mode	Code entered
Press 1 time:	Parameter mode	Standby mode
Press 2 times:	Information mode	Parameter mode
Press 3 times:	Standby mode	Information mode
Press 4 times:	Connection mode
Press 5 times:	Fan mode
Press 6 times:	Error mode
		Standby mode

Table 1 Default parameter settings (as they appear in Gascom software and Boiler display) — **DO NOT** change any parameter unless the application requires special settings

Para. No.	Parameter description	Ultra-80 thru -230				Ultra-310 ONLY			
		Standard (to 5500 feet)		High altitude		Standard (to 5500 feet)		High altitude	
		Gascom software	Boiler display	Gascom software	Boiler display	Gascom software	Boiler display	Gascom software	Boiler display
17	Minimum fanspeed	1300 rpm	13	2000 rpm	20	1400 rpm	14	2000 rpm	20
19	Ignition fanspeed	2700 rpm	27	3500 rpm	35	2300 rpm	23	3200 rpm	32



Weil-McLain
500 Blaine Street
Michigan City, IN 46360-2388
<http://www.weil-mclain.com>