

WEIL-McLAIN



PFG

SERIES 6

GAS BOILER

NET LOAD RANGE

**HOT WATER:
173,000 to
301,000 BTU/Hr.**

AMERICA'S MOST COMPLETE LINE OF CAST IRON BOILERS
RESIDENTIAL ... COMMERCIAL ... INDUSTRIAL ... INSTITUTIONAL

PFG

GAS BOILER

WEIL-McLAIN

MICHIGAN CITY INDIANA

The Weil-McLain PFG is a medium-capacity, cast iron package boiler designed for forced hot water heating systems in apartments, large residences, and commercial and institutional buildings. The unit is available in four sizes with net I-B-R water ratings from 173,000 to 301,000 BTU/Hr.

An outstanding feature of the PFG is the compact design. The low height of the unit—only 30 $\frac{1}{2}$ "—reduces headroom requirements. Other features include cast iron sectional construction, convenient servicing, high operating efficiency and long life.

Most important, the PFG is made by Weil-McLain, the leading name in cast iron boilers for over a century.

MULTIPLE BOILER SYSTEMS

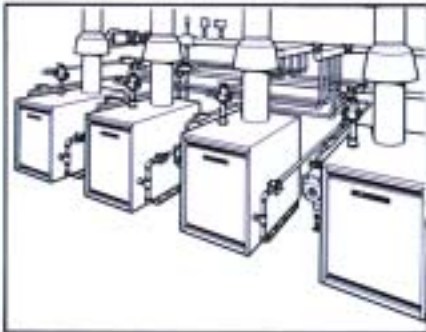

Two or more PFG boilers can be used in place of one large-capacity boiler to meet the space heating requirements of larger buildings.

With multiple PFG boilers, system operating efficiency is increased since the boilers can be sequenced so only those required to meet the heating load are fired. In addition, individual boilers may be isolated from the system if service is ever required, and additional boilers may be added to the system if heating requirements increase.

Weil-McLain also has special Easy-Fit® manifolds to simplify piping, plus a number of Energy Management Control Systems (EMCS) for multiple boiler applications. Refer to Weil-McLain MBS product literature.

DESIGN ADVANTAGES



- 1 HIGH OPERATING EFFICIENCY.** PFG-5 operates at 81% efficiency exceeding the 80% minimum DOE efficiency required by the National Appliance Energy Conservation Act. PFG-5 through 8 exceed the efficiency requirements of ASHRAE 90.1.
- 2 FACTORY TESTED.** Every PFG boiler is factory tested to assure reliable operation.
- 3 COMPACT DESIGN.** Saves valuable space. The PFG is only 30 $\frac{1}{2}$ " high, 34 $\frac{1}{2}$ " deep.
- 4 AUTOMATIC VENT DAMPER.** Prevents heat from escaping up the chimney when the burners are not operating to increase efficiency and save fuel. Furnished as standard equipment for PFG-5; additional equipment for PFG-6, 7 and 8.
- 5 VENT PROVING CONTROLS.** Rollout thermal fuse element and spill switch furnished with PFG-5 shut down the unit if blockage occurs in either the boiler or venting system.
- 6 WIRING HARNESS.** Designed, labeled, and color-coded to help assure correct wiring.
- 7 CONVENIENT SERVICING.** Easily accessible controls ... top cleaning ... vertical flueways.
- 8 STEEL JACKET.** Durable powder-coat finish in Weil-McLain blue. Insulated to retain heat. Clear of the floor to prevent rust.
- 9 PROTECTIVE CRATE.** The PFG is mounted on a pallet in a sturdy wire-bound crate. Ready for fast installation.

CAST IRON CONSTRUCTION

Boiler sections are made of durable cast iron for strength and long life. It's not uncommon for Weil-McLain cast iron boilers to last 35 years or more.

The vertical flue passages are studded with tips that cause the hot gases to swirl about, scrubbing the entire surface of each section for maximum heat transfer. Radiation plates further increase heat transfer for maximum efficiency.

A special high-temperature sealant is used between sections to assure a gastight assembly and consistently high efficiency. The sealant is flexible to allow for expansion and contraction, is impervious to heat and moisture, and will last the life of the boiler.

Sections are hydrostatically tested *twice*—before and after assembly—to assure reliability.



CONTROL SYSTEMS



PFG-5 and 8 boilers are furnished with an intermittent electronic ignition system. PFG-6 and 7 boilers may be furnished with either an intermittent ignition system or a standing pilot system. **NOTE:** When an automatic vent damper is used with the PFG-6 and 7, an intermittent ignition system must be used.

BUILT-IN AIR SEPARATOR

The PFG features a built-in air separator ... no need to add an air eliminating device.

An illustrated, rising air bubbles are diverted to the expansion tank through a $\frac{1}{2}$ " tapping located next to the supply outlet.



GASES AND BURNERS



All PFG boilers are C S A design certified for natural gas. PFG-6 through 8 boilers are also design certified for propane gas.

One-piece, high-temperature, aluminized steel burners feature highly efficient operation, excellent flame characteristics, and quiet ignition and extinction.

EASY CLEANING AND SERVICING

By removing the top jacket panel and collector hood, PFG flueways are exposed for straight-through cleaning. All heating surfaces in this boiler can be cleaned for continued high efficiency.

Removing the front jacket door and the burner-access panel permits access to the burners, which can be removed individually. The front and back steel base panels are lined with high-temperature insulating material; end sections rest on the floor.

PFG
GAS BOILER

WEIL-McLAIN

RATINGS AND ENGINEERING DATA



Water Boiler Number	Input BTU/Hr.	Gross Output BTU/Hr.	Net I-B-R Ratings BTU/Hr.**	Boiler H.P.	Chimney Size
PFG-5-PIDN	244,000	189,000*	173,000	5.9	7" I.D. x 20'
PFG-6-A	305,000	247,000	215,000	7.4	8" I.D. x 20'
PFG-7-A	366,000	296,000	257,000	8.8	9" I.D. x 20'
PFG-8-PIN	427,000	346,000	301,000	10.3	9" I.D. x 20'

Water Boiler Number	No. & Size of		Gas Connection Size Natural and Propane	Draft Hood Outlet Size	Dimensions of Crate (Outside Dimensions)			Approximate Shipping Weight (lbs.)
	Flows	Returns			Length	Width	Height	
PFG-5-PIDN	1-2"	1-2"	N"	7"	38 1/2"	25"	33 1/2"	500
PFG-6-A	1-2"	1-2"	N"	8"	38 1/2"	25"	33 1/2"	575
PFG-7-A	1-2"	1-2"	N"	9"	38 1/2"	31"	33 1/2"	635
PFG-8-PIN	1-2"	1-2"	1"	9"	38 1/2"	31"	33 1/2"	695

▲ Add "SPN" for standing pilot or "PIN" for intermittent ignition.
 * DOE heating capacity in BTU/Hr. based on standard test procedures prescribed by the United States Department of Energy, PFG-5 AFUE - B1S.
 ** Net I-B-R ratings are based on net installed radiation of sufficient quantity for the requirements of the building and nothing need be added for normal piping and pickup. Ratings are based on a piping and pickup allowance of 1.15. An additional allowance should be made for unusual piping and pickup loads. Ratings shown are for elevations up to 2,000 feet. For elevations above 2,000 feet, ratings should be reduced at the rate of 4 percent for each 1,000 feet above sea level.

NOTE: Boilers tested for 50 P.S.I. working pressure, C.S.A. design certified for installation on non-combustible flooring only.

DIMENSIONS

Water Boiler Number	Dimensions in inches			
	A	B	D	W
PFG-5	15	23 1/2	7	17 1/2
PFG-6	17 1/4	27 1/2	8	20 1/2
PFG-7	19 1/2	30 1/2	9	23 1/2
PFG-8	25	35 1/2	9	26 1/2

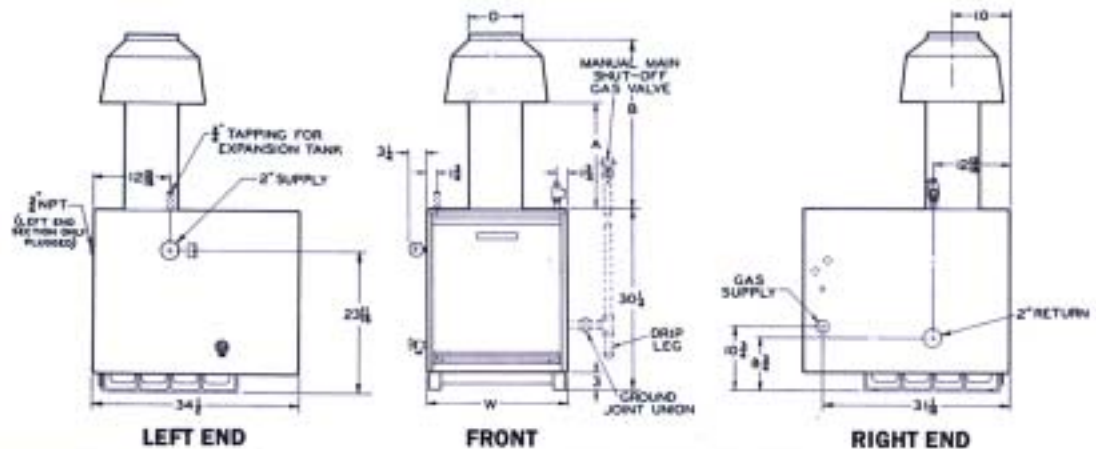

RECOMMENDED PIPING CONNECTIONS

Supply and return sizes refer to minimum size of pipe connected to the boiler for 20°F or higher temperature drop between supply and return.

Boiler Size	Min. Pipe Size	
	Supply (A)	Return (B)
PFG-5	1 1/2"	1 1/2"
PFG-6	2"	2"
PFG-7	2"	2"
PFG-8	2"	2"

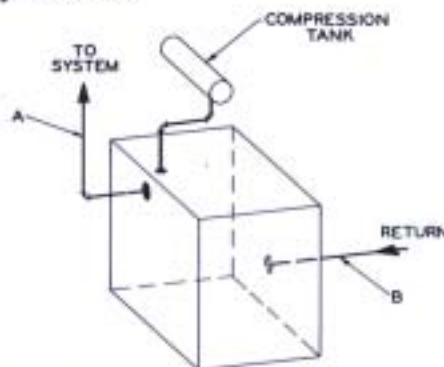

In the interest of continual improvement in products and performance, Weil-McLain reserves the right to change specifications without notice.

STANDARD EQUIPMENT

- Factory Tested
- Insulated Extended Jacket
- Built-in Air Separator
- Vertical Draft Hood (packed separately)
- Automatic Vent Damper (PFG-5 only)
- Radiation Plates
- Combination Gas Valve for 24 Volt
- Constant Burning, Thermally Supervised Pilot System and Thermocouple (PFG-6 and 7 only)
- Intermittent Electronic Ignition System (PFG-5 and 8 only)
- Non-Linting Pilot Burner
- Aluminized Steel Burners
- Combination Relay Receptacle and 40 VA Transformer
- Electrical Junction Box
- Plug-in Circulator Relay
- Spill Switch (PFG-5 only)
- Rollout Thermal Fuse Element (PFG-5 only)
- High-Limit Temperature Control
- 30 PSI ASME Relief Valve (boiler sections tested for 50 PSI working pressure) packed separately
- Combination Pressure-Temperature Gauge (packed separately)
- Drain Valve (packed separately)

ADDITIONAL EQUIPMENT

- Intermittent Electronic Ignition Pilot System for PFG-6 and 7 (Standard for PFG-5 and 8)
- Automatic Vent Damper for PFG-6 through 8 (Standard for PFG-5)
- Gas Conversion Kits



Locate our Sales Offices by visiting our website:
www.weil-mclain.com

Weil-McLain
 500 Blaine Street
 Michigan City, IN 46360-2388