

Water Boiler - Series 3
For use with Gas, Light Oil, and Gas
with Light Oil Fired Burners

Boiler Manual



⚠ WARNING

Installation and service of the boiler must be performed by a qualified installer or service technician. Read all instructions, including this manual and all other information shipped with the boiler, before installation or operation. Perform steps in the order given. Failure to comply could result in severe personal injury, death or substantial property damage.

Contents

Tools	3	Test Procedure for Existing Vent System.	34
Abbreviations	3	Room Air Openings	35
SECTION 1 - SAFETY	5	Combustion Air Provision.	35
Safety Signals	5	Sizing Combustion Air Openings	35
Please Read Before Proceeding	5	Special Considerations	35
Servicing a Boiler	5	Gas Venting Requirements — Category II	37
Boiler Operation	6	Using a Chimney	37
Boiler Water	6	Vent Piping Materials	37
Commonwealth of Massachusetts	6	Gas Venting Requirements — General.	38
Freeze Protection Fluids	6	General Gas Venting Information.	38
Damage from Water Contact	6	Engineered Vent System	38
Frozen Water Damage	6	Types of Gas Venting Systems	39
SECTION 2 - INSTALLATION	7	Oil Venting Requirements.	40
Prepare Boiler Location.	7	Using a Chimney	40
Installation Compliance Requirements	7	Vent Piping Materials	40
Checks Before Boiler Installation	7	General Oil Venting Information	41
Flooring and Foundation	8	Engineered Vent System	41
Garage Installation	8	Types of Oil Venting Systems	42
Air Openings	8	Install Burner and Fill the System	43
Clearances	9	Burner Installation	43
Prepare the Boiler	10	Wire the Burner and Boiler Controls	43
Removing a Packaged Boiler from the Crate.	10	Water Treatment	44
Removing a Preamsembled Block from the Crate	11	Freeze Protection (when used).	44
Boiler Assembly	12	Fill the Water Boiler System	44
Assembling the Block.	12	Fuel Piping	45
Perform Hydrostatic Pressure Test	15	Gas Piping	45
Complete the Block Assembly	16	Fuel Oil Piping	46
Damper Connector Installation	18	Final Adjustments	47
Connect Water Boiler Piping	20	Adjust the Burner and Damper Assembly	47
General Water Piping Information	20	Check the Boiler for Gas-Tight Seal	47
Install Water Piping	20	SECTION 3 - MAINTENANCE	49
Bypass Circulator Sizing	21	Maintenance - General	49
Install the Jacket.	22	Handling Ceramic Fiber Materials	49
Preparing for Jacket Installation	22	Perform Startup and Checkout	49
Removal of Jacket Parts	22	Annual Inspection	50
Install Support Brackets and Channels.	22	General Inspection Information.	50
Install the Jacket Front and Back Panels.	24	Inspect the Boiler Area	50
Install Jacket Side Panels	24	Inspect All Piping for Leaks.	50
Install Top Insulation	26	Inspect the Boiler Interior	50
Install Jacket Top Panels	26	Check Air Openings	50
Install Jacket Trim	26	SECTION 4 - PARTS	51
Tankless Heaters	28	Ordering	51
Hot Water Precautions	28	Replacement Parts	52
Piping Tankless Heaters	28	Dimensions	54
Water Boiler Controls	29	SECTION 5 - SERVICE INFORMATION	57
Installing the Controls	29	Ratings	57
Condensate Trap	30	Maintenance Log	58
Condensate Drain Trap Construction.	30	Installation and Service Certificate.	59
Commonwealth of Massachusetts Installations.	32	Notes	59
Venting and Combustion Air - General.	33		
Code Compliance	33		
Combustion Air Contamination	33		
Dual Fuel Venting Requirements	33		
Venting and Combustion Air Options	34		
Existing Category I Vent System	34		



Tools

Table 1 Common tools needed

Tools Needed	Purpose
1/16" flat blade screwdriver	Wiring onto terminal blocks.
Phillips head screwdriver	Jacket posts and channels
5/16" wrench or socket	Sight glass
11 mm wrench or socket	Cover plate bolts
3/4" wrench or socket	Burner mounting plate
15/16" wrench or socket	Castings to castings tie rod nuts
1-1/16" wrench or socket	Limit control
9/16" wrench	Pressure and temperature gauge
Flat head screwdriver	Sight glass
Pipe wrench	Water piping and plugs
Multimeter	Measurement readings on sensors and electrical components
Manometer (inclined or digital)	Measuring the gas pressure coming to the boiler
Combustion analyzer (digital preferred)	Combustion testing
Contact thermometer	Checking surface temperatures of the heat exchanger and pipes

Abbreviations

Table 2 Common abbreviations

Abbreviation	Description
AHRI	Air-Conditioning, Heating, and Refrigeration Institute
ANSI	American National Standards Institute
ASME	American Society of Mechanical Engineers
AWG	American Wire Gauge
BTUH	British Thermal Unit per Hour
CFM	Cubic Feet Per Minute
CO	Carbon Monoxide
CO ₂	Carbon Dioxide
CP	Consumer Protection
HX	Heat Exchanger
LWCO	Low Water Cut-Off
MAWP	Maximum Allowable Working Pressure
MBH	Thousands of Btuh
NFPA	National Fire and Protection Agency
NIOSH	National Institute for Occupational Safety and Health
W.C.	Water Column

This page intentionally left blank



SECTION 1

Safety

This section is intended to provide safety information for installers and users.

Section Contents

Safety Signals	5
Please Read Before Proceeding	5

Safety Signals

The following defined terms are used throughout this manual to bring attention to the presence of hazards or other important information.

⚠ DANGER

Danger indicates the presence of hazards that will result in severe personal injury, death, or substantial property damage.

⚠ WARNING

Warning indicates the presence of hazards that can result in severe personal injury, death, or substantial property damage.

⚠ CAUTION

Caution indicates the presence of hazards that will or can result in minor personal injury or property damage.

NOTICE

Notice indicates additional information that may be related to property damage, but is not related to personal injury.

IMPORTANT

Important indicates additional information that is important, but is not related to personal injury or property damage.

Please Read Before Proceeding

⚠ WARNING

Adhere to all following guidelines and instructions in this section. Failure to adhere to these guidelines can result in severe personal injury, death, or substantial property damage.

Installer: Read all instructions, including this manual and all other information shipped with the boiler, before installation. Perform steps in the order given. Consider piping and installation when determining boiler location.

User: This manual is for use only by a qualified heating installer or service technician. A qualified service technician should inspect and service this boiler at least once per year.

Write the Consumer Protection (CP) number and serial number in the space provided on the Installation and Service Certificate on [page 59](#). The CP number can be found on the boiler jacket.

Please include the boiler model number, CP number, and serial number when calling or writing about the boiler. The model number can be found on the boiler rating label.

IMPORTANT

Any claims for damage or shortage in shipment must be filed immediately against the transportation company by the consignee.

Servicing a Boiler

- To avoid electric shock, disconnect all electrical supplies to the boiler before performing maintenance.
- To avoid severe burns, allow boiler to cool before performing maintenance.
- This boiler contains ceramic fiber and fiberglass materials. Refer to the warning and instructions on [page 49](#).



Please Read Before Proceeding, continued

Boiler Operation

- Do not block flow of combustion or ventilation air to boiler.
- Should overheating occur, or gas supply fail to shut off, do not turn off or disconnect electrical supply to pump. Shut off the gas supply at a location external to the appliance.

Boiler Water

- Since the heat exchanger is made of cast iron, the water chemistry must be checked. The system pH must be in the range of 7.0 to 8.5. Chemical treatment may be required. See [page 44](#) for details.
- Before connecting the boiler, thoroughly flush the system to remove sediment. Install a strainer or other sediment removal equipment if necessary. The cast iron heat exchanger can be damaged by build-up or corrosion due to sediment.
- Do not use petroleum-based cleaning or sealing compounds in the boiler system. Gaskets and seals in the system may be damaged, which can result in substantial property damage.
- Continual fresh make-up water will reduce boiler life. Mineral buildup in the heat exchanger reduces heat transfer, overheats the cast iron heat exchanger, and causes failure. Addition of oxygen carried in by make-up water can cause internal corrosion. Leaks in the boiler or piping must be repaired at once to prevent make-up water. Use this boiler **ONLY** in a closed-loop system.
- Do not add cold water to a hot boiler. Thermal shock can cause the heat exchanger to crack.

Commonwealth of Massachusetts

When the boiler is installed within the Commonwealth of Massachusetts:

- This product must be installed by a licensed plumber or gas fitter.
- If antifreeze is used, a reduced pressure back-flow preventer device shall be used.

See [page 32](#) for sidewall vent air installations.

Freeze Protection Fluids

NEVER use automotive or standard glycol antifreeze. Use antifreeze specifically made for hydronic systems; inhibited propylene glycol is recommended. See [page 44](#) for more information. Thoroughly clean and flush any replacement boiler system that has used glycol before installing the new 88 boiler.

Damage from Water Contact

⚠ DANGER

DO NOT attempt to operate any boiler if any part of the boiler, burner, or controls has been partially or fully sprayed with or submerged under water. The boiler must either be replaced or completely repaired and inspected. The boiler and all components must be in good condition and fully reliable before operation.

If these requirements are not met, operating the boiler will cause fire, explosion, and electrical shock hazards, leading to serious injury, death, or substantial property damage.

Saltwater damage: The immediate effects of saltwater damage are like those of freshwater, with electrical components shorting out and the removal of critical lubricants. However, salt and other contaminants left behind can lead to long term issues due to the conductive and corrosive nature of salt residue. WM Technologies equipment contaminated with saltwater or polluted water will no longer be covered under warranty and should be replaced.

Electrical damage: If any electrical component or wiring has, or is suspected to have come into contact with water, replace the boiler.

Frozen Water Damage

Power outages, unattended residences or buildings, boiler component failures, or other electrical system failures in cold weather could result in frozen plumbing and water damage in a matter of hours. Consult with a boiler contractor or a home security agent to take preventative actions, such as installing a security system that operates during power outages, senses low temperature, and initiates an effective action.

SECTION 2

Installation

This section is intended to provide installation instructions for qualified heating installers.

Section Contents

Prepare Boiler Location	7
Prepare the Boiler	10
Boiler Assembly	12
Connect Water Boiler Piping	20
Install the Jacket	22
Tankless Heaters	28
Water Boiler Controls	29
Condensate Trap	30
Commonwealth of Massachusetts Installations	32
Venting and Combustion Air - General	33
Venting and Combustion Air Options	34
Room Air Openings	35
Gas Venting Requirements — Category II	37
Gas Venting Requirements — General	38
Oil Venting Requirements	40
Install Burner and Fill the System	43
Fuel Piping	45
Final Adjustments	47

Prepare Boiler Location

Installation Compliance Requirements

- Local, state, provincial, and national codes, laws, regulations, and ordinances.
- National Fuel Gas Code – ANSI Z223.1/NFPA 54, latest edition.
- Chimneys, Fireplaces, Vents, and Solid Fuel Burning Appliances – ANSI/NFPA 211, latest edition.
- Installation of Oil Burning Equipment – ANSI/NFPA 31, latest edition.
- National Electrical Code – ANSI/NFPA 70, latest edition.
- Where required by the authority having jurisdiction, the installation must conform to the Standard for Controls and Safety Devices for Automatically Fired Boilers – ANSI/ASME CSD-1, latest edition.

IMPORTANT

The 88 Series 3 water boiler met safe lighting and other performance criteria when the boiler underwent tests specified in UL 726 & UL 795, latest editions.

Checks Before Boiler Installation

1. Check for nearby connections to:
 - System water piping
 - Venting systems
 - Fuel supply
 - Electrical Power
 - Combustion and ventilation air supply
2. Check area around boiler. Remove any combustible materials, gasoline, and other flammable liquids and vapors.

WARNING

Failure to keep boiler area clear and free of combustible materials, gasoline, and other flammable liquids and vapors can create an explosion hazard, which can result in severe personal injury, death, or substantial property damage.

3. Check the boiler location to ensure it protects the gas control system components from dripping or spraying water and rain during operation or service.
4. If a new boiler is replacing the existing boiler, check for and correct system problems:
 - System leaks causing oxygen corrosion or heat exchanger cracks from hard water deposits.
 - Incorrect expansion tank sizing.
 - Lack of freeze protection in boiler water.



Prepare Boiler Location, continued

Flooring and Foundation

The 88 Boiler is approved for installation on combustible flooring, but must never be installed on carpeting.

⚠ WARNING

Do not install the boiler on carpeting even if a foundation is used. Installing a boiler on carpeting can cause a fire, which can result in severe personal injury, death, or substantial property damage.

1. The boiler mounting surface must be level and suitable for the load.
2. Provide a solid foundation pad at least 4.0" (101.6 mm) above the floor if any of the following is true:
 - Floor can become flooded.
 - The floor is dirt, sand, gravel, or other loose material.
 - The boiler mounting area is severely uneven or sloped.
3. Foundation may be brick or concrete construction. The minimum foundation dimensions are listed in Table 3.
4. If flooding is possible, elevate the boiler sufficiently to prevent water from reaching the boiler.

Garage Installation

Take the following special precautions when installing the boiler in a garage.

- Mount the boiler at a height above the floor as specified in the latest edition of the National Fuel Gas Code – ANSI Z223.1/NFPA 54, latest edition, for U.S. installations.
- Locate or protect the boiler so it cannot be damaged by a moving vehicle.
- Ensure that the installation complies with all applicable codes.

Table 3 Minimum foundation dimensions

Boiler Model	Minimum Dimensions (inches)
488	33 x 39 x 4
588	41 x 39 x 4
688	49 x 39 x 4
788	57 x 39 x 4
888	65 x 39 x 4
988	73 x 39 x 4
1088	81 x 39 x 4
1188	89 x 39 x 4
1288	97 x 39 x 4
1388	105 x 39 x 4
1488	113 x 39 x 4
1588	121 x 39 x 4
1688	129 x 39 x 4
1788	137 x 39 x 4
1888	145 x 39 x 4

Air Openings

Openings in floors, walls, ceilings, or roofs must be designed for fire stopping as required by local codes.

Vent pipe openings through combustible materials must be 3/8" (9.5 mm) larger in diameter than the vent pipe.

Air pipe openings should be 3/8" (9.5 mm) larger in diameter than the pipe or as required by the pipe manufacturer.

⚠ WARNING

Pipe openings that do not have the required diameter can cause a fire, which can result in severe personal injury, death, or substantial property damage.

Provide air openings for combustion air and ventilation of the room. Follow the National Fuel Gas Code – ANSI Z223.1/NFPA 54, latest edition for the U.S.

Follow all applicable codes to size and verify size of the combustion and ventilation air openings into the space. See the Venting and Combustion Air sections starting on [page 33](#) for required air openings and sizing.

Clearances

There are minimum clearance requirements for the boiler from combustible surfaces. There are recommended service access clearances. See Figure 1 for all clearances.

IMPORTANT

Without the recommended minimum clearances for service access, it may not be possible to service the boiler without removing it from the space.

Figure 1 Clearances for 88 Boilers

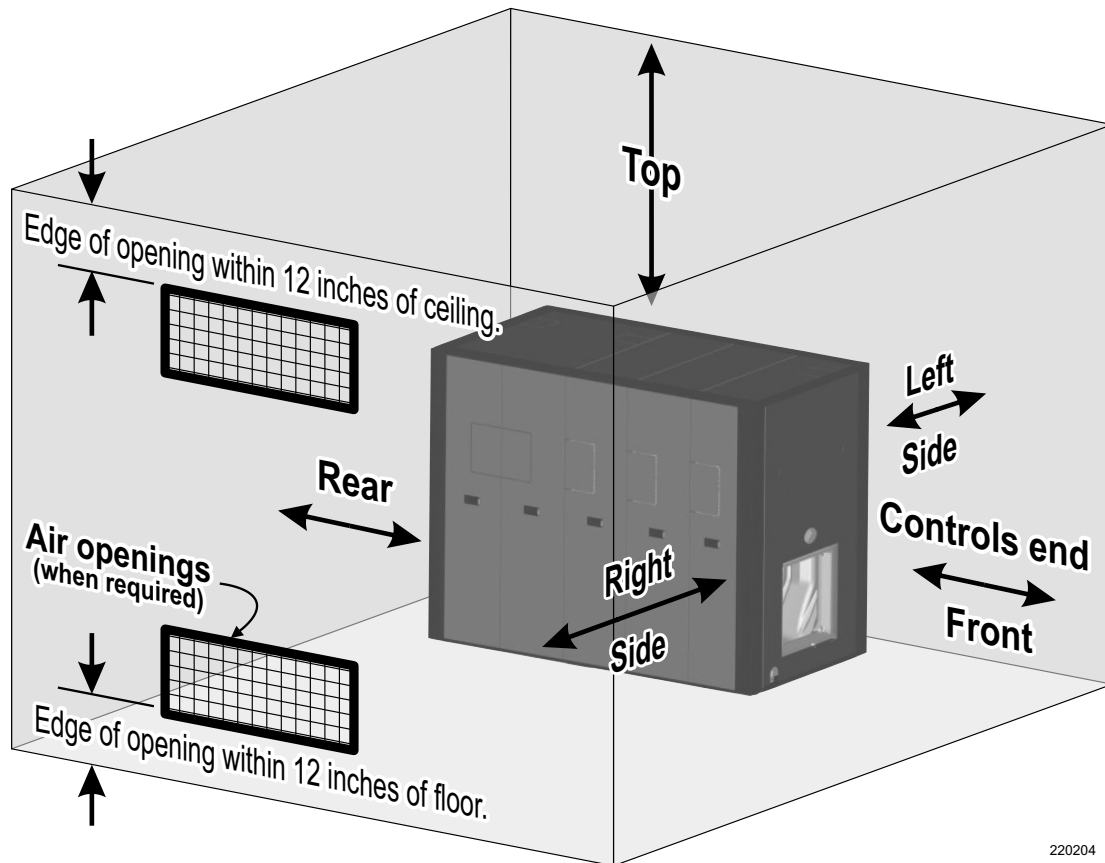

220204

Ensure that the installation complies with all state, local, and applicable codes.			
Clearance from:	Minimum clearances to combustible surfaces (inches)	Minimum allowable service clearances (inches)	Recommended minimum service access clearances (inches)
Controls end (Front)	48	48	48
Left side	6	34	39 (clean and remove tankless heater)
Right side	6	6	6
Flue	9	9	9*
Rear	9	9	36 (breaching)*
Top	24	24	24
Floor	0	0	0
Single-wall vent pipe	18	18	18
Double-wall vent pipe	Refer to vent pipe manufacturer's recommendations for vent pipe clearances.		
Note: Allow sufficient space for cleaning, servicing, and installing the burner. See burner literature for length and recommended service clearances.			
*Flue pipe and breaching clearances take precedence over jacket clearances.			

Prepare the Boiler

Removing a Packaged Boiler from the Crate

Leave the boiler in the crate pallet until ready to place in the final location. Follow all removal instructions.

IMPORTANT

Cables used for lifting are not provided by Weil-McLain.

⚠WARNING

Ensure the equipment and cables used for lifting are designed to handle the load. See Table 4 for approximate weights of section assemblies. Failure to comply can result in severe personal injury, death or substantial property damage.

1. Move the crate to a solid, level surface. The crate must be sitting securely on the ground.
2. Remove the top jacket panels and set aside until after piping installation.
3. Remove four lag screws from the shipping brackets.
4. Remove the boiler from the skid with a crane or a hoist. See Table 4 for lifting weight.
 - Crane: Hook middle of each cable to the eye of the crane.
 - Hoist: Hook middle of each cable to the hoist. Raise boiler off skid. Use pipe rollers under skid angles to roll the boiler.
5. Place the boiler in the final position. If using a foundation, center the boiler on the foundation.
6. Level the boiler. Shim under skid angles if necessary.
7. Cut off the cables.

⚠WARNING

Cables are not intended for long-term use. Cables may corrode inside the boiler, weakening their lifting strength. Failure to remove cables can result in severe personal injury, death, or substantial property damage.

8. Proceed to [page 15](#) and perform pressure testing.

Table 4 Section assembly lifting weights

Boiler Model Number	Approximate Lifting Weight (lbs.)	Minimum Sling Length (from Crane Hook to Boiler Lifting Lugs)
488	2,928	2' 6"
588	3,490	3' 0"
688	4,152	4' 0"
788	4,714	4' 6"
888	5,276	5' 0"
988	5,838	6' 0"
1088	6,400	6' 6"
1188	7,062	7' 0"
1288	7,624	8' 0"
1388	8,186	8' 6"
1488	8,748	9' 0"
1588	9,310	10' 0"
1688	9,872	10' 6"
1788	10,584	11' 0"
1888	11,146	12' 0"

Removing a Preassembled Block from the Crate

Leave the block assembly in the crate pallet until ready to place in the final location. Follow all removal instructions.

IMPORTANT

Cables used for lifting are not provided by Weil-McLain.

⚠WARNING

Ensure the equipment and cables used for lifting are designed to handle the load. See [Table 4, page 10](#) for approximate weights of section assemblies. Failure to comply can result in severe personal injury, death or substantial property damage.

1. Move the crate to a solid, level surface. The crate must be sitting securely on the ground.
2. Remove four lag screws from the shipping brackets.
3. Remove the block assembly from the skid with a crane or a hoist. See [Table 4, page 10](#) for lifting weight.
 - Crane: Attach free end of cables to the eye of the crane.
 - Hoist: Attach free end of cables to the hoist. Raise the block off the skid. Use pipe rollers under skid angles to roll the block.
4. Place the block assembly in the final position. If using a foundation, center the boiler on the foundation.
5. Level the block. Shim under skid angles if necessary.
6. Cut off the cables.

⚠WARNING

Cables are not intended for long-term use. Cables may corrode inside the boiler, weakening their lifting strength. Failure to remove cables can result in severe personal injury, death, or substantial property damage.

7. Inspect the block assembly for disjointed sections.
8. Check the gas-tight seal of the flue collector hood and clean out plates.
 - a. Check inside the section assembly for any light passing through unsealed areas.
 - b. Mark all unsealed areas and check for the following:
 - Damaged gaskets.
 - Displaced sealing rope.
 - Loose bolts or nuts.
 - c. Correct all conditions and repeat the previous steps. If unsealed areas still exist, contact Tech Services before continuing with installation.

⚠WARNING

Gas-tight seal must be maintained to prevent possible flue gas leakage and carbon monoxide emissions. Leakage and emissions can result in severe personal injury or death.

9. Proceed to [page 15](#) and perform pressure testing.

Boiler Assembly

Assembling the Block

WARNING

Ensure sections are supported. Sections are top-heavy. Unbolted sections may fall if not supported, which can result in severe personal injury or death.

Prepare and position the back section:

1. Apply a 1/8" continuous bead of sealing rope adhesive in the sealing rope grooves. *Do not* get any adhesive on machined port surfaces. See Figure 2.
2. Place 1/2" sealing rope into the groove. When placing the rope around curves, grasp at 1" intervals and push together; do not stretch.
3. The silicone-coated rope must be held in place until the adhesive hardens.
 - a. Apply duct tape over the rope at the corners to hold the rope in place. *Do not* apply duct tape to any machined surface. Refer to Figure 3.
 - b. Keep the tape on for at least one hour to ensure a bond between the rope and adhesive.
 - c. Once the adhesive has hardened, remove the duct tape before assembling sections together.
4. Cut the rope as each section is completed.

WARNING

Do not pre-cut rope. Gas-tight seal must be maintained to prevent the possibility of flue gas leakage and carbon monoxide emissions. Failure to comply can result in severe personal injury or death.

NOTICE

Do not use petroleum based cleaning or sealing compounds in the boiler system, as it can result in severe boiler damage and substantial property damage.

5. Remove any grit from port machined surfaces with a clean rag.
6. Place 9" and 6" sealing rings in appropriate port openings. See Figure 2. If sealing ring slips out of groove, stretch ring gently and reposition in groove.
7. Apply continuous bead of silicone sealant no larger than 1/16" around entire outside edge of outer machined surface of port. Refer to Figure 4. *Do not* apply silicone sealant on, next to or under sealing ring.

Figure 2 Sealing rope installation

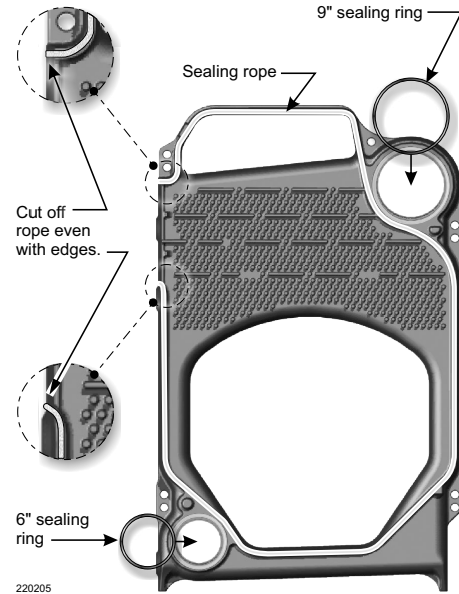

Figure 3 Holding rope in place

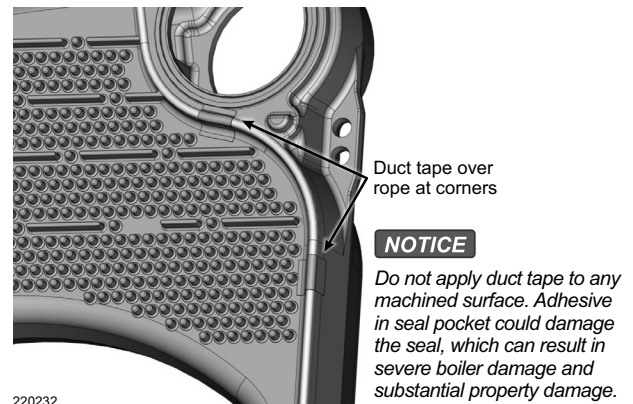
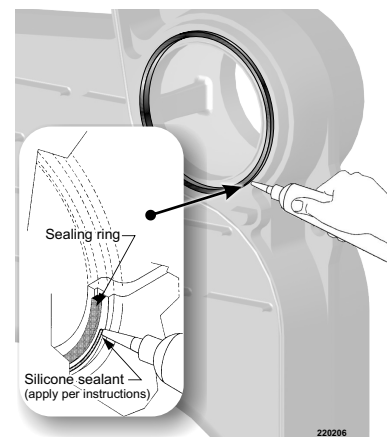

Figure 4 Silicone sealant



NOTICE

Apply silicone sealant as specified to prevent unburned oil vapors from coming in contact with the sealing ring, which can result in severe boiler damage and substantial property damage.

Assembling the Block, continued

8. Hoist the back section upright. Temporarily screw a 6" threaded pipe at least 36" long into the lower (return) tapping.
9. Hoist the section and put into position.
10. Place a block under the 6-inch pipe to hold the back section upright and plumb.

⚠ CAUTION

The back section must be plumb before installing other sections to ensure correct block assembly.

11. The 6" support pipe and block can be removed after several sections have been installed and the assembly is stable.

Install the intermediate sections:

12. Remove and discard 3/8" diameter shipping tie rods.
13. Remove grit from port machined surfaces with clean rag.
14. Position the intermediate section so aligning lugs fit into sockets of next section. See Figure 5.
15. Install tankless intermediate (TI) sections (when used) in the order shown in [Table 5, page 14](#).
16. Draw the sections together until metal-to-metal contact is made around machined port openings as shown in Figure 5.
 - a. Oil the threads on four draw rods. Install a washer and nut on the end to be tightened. Use a nut only on other end.
 - b. Uniformly draw the sections together, starting at the washer/nut end.

NOTICE

Leave an equal amount of thread on each end of the draw rod; this is needed to allow securing the jacket support brackets in place.

- c. Draw rods should be torqued to a range of 100 to 120 ft-lbs. *Do not* back off draw rods.
- d. Metal-to-metal contact will be achieved around port openings. See Figure 5. If gap occurs, it should be no greater than .032". Check with a feeler gauge.
- e. If the gap around the machined port opening exceeds .032", check for rope extending from rope grooves, dirt on port openings or

Figure 5 Sealing ring installation and port alignment

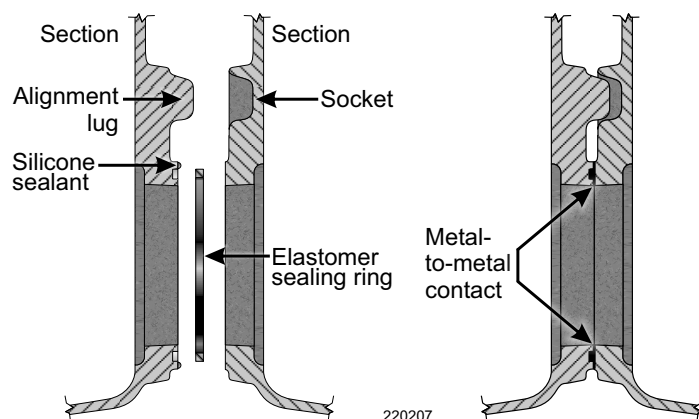

sockets, or misaligned lugs. If corrections are made and a gap still exists, contact your WM Technologies distributor before continuing installation.

NOTICE

After erecting the first intermediate section, check both sections for plumb. Failure to plumb sections can cause misaligned piping and breeching, which can result in property damage.

⚠ WARNING

A gas-tight seal prevents possible flue gas leakage and carbon monoxide emission. Failure to position sealing rope properly can cause boiler to not seal gas-tight, which can result in severe personal injury or death.

17. Check each section for proper sealing rope position before proceeding to next section.
18. Install remaining intermediate sections and front section using the same procedure in this section.

If using tankless heater (TI) sections:

- Install tankless heaters and gaskets or heater cover plates and gaskets. Use 3/8" x 3/4" studs, washers and nuts.

Boiler Assembly, continued

Table 5 Hydrostatic test piping connections

Boiler model number W = water	Max. number of tankless heaters	<p style="text-align: center;">Section arrangement (All heaters must be on left side of boiler)</p> <div style="border: 1px solid black; padding: 5px; margin: 10px auto; width: fit-content;"> <p>F = front / B = back / I = intermediate TI = tankless intermediate "I" can be substituted for "TI" sections</p> </div>
488 W	1	F • TI • I • B
588 W	2	F • TI • I • TI • B
688 W	2	F • TI • I • TI • I • B
788 W	3	F • TI • I • TI • I • TI • B
888 W	3	F • TI • I • TI • I • TI • I • B
988 W	4	F • TI • I • TI • I • TI • I • TI • B
1088 W	4	F • TI • I • TI • I • TI • I • TI • I • B
1188 W	5	F • TI • I • TI • I • TI • I • TI • I • TI • B
1288 W	5	F • TI • I • TI • I • TI • I • TI • I • TI • I • B
1388 W	6	F • TI • I • TI • I • TI • I • TI • I • TI • I • TI • B
1488 W	6	F • TI • I • TI • I • TI • I • TI • I • TI • I • TI • I • B
1588 W	7	F • TI • I • TI • I • TI • I • TI • I • TI • I • TI • I • TI • B
1688 W	7	F • TI • I • TI • I • TI • I • TI • I • TI • I • TI • I • TI • I • B
1788 W	8	F • TI • I • TI • I • TI • I • TI • I • TI • I • TI • I • TI • I • TI • B
1888 W	8	F • TI • I • TI • I • TI • I • TI • I • TI • I • TI • I • TI • I • TI • I • B

2



Perform Hydrostatic Pressure Test

1. See Figure 6 for tapping locations. Install the following:
 - a. Boiler drain (not furnished).
 - b. Water pressure gauge for test only. Be sure the gauge can handle test pressure.
 - c. Air vent in the upper tapping (K).
2. Plug remaining tappings.

NOTICE

Do not pressure test with any control installed. Damage to control can occur due to overpressure.

WARNING

Do not leave boiler unattended. Cold water fill could expand and cause excessive pressure, which can result in severe personal injury, death or substantial property damage.

3. Fill the boiler and vent all air.
4. Pressure test at least 10 minutes at a pressure at 1.5 times the maximum allowable working pressure (MAWP). The MAWP is stamped on the boiler nameplate, located on the jacket front panel.
5. Check for maintained gauge pressure and leaks. Repair any leaks immediately.

NOTICE

Do not exceed the above test pressure by more than 10 psig.

NOTICE

Leaks must be repaired at once. Failure to do so can damage boiler, resulting in substantial property damage.

NOTICE

Do not use petroleum-based cleaning or sealing compounds in boiler system. Using these compounds can cause severe damage to system components, resulting in substantial property damage.

6. Drain the boiler. Remove the air vent, boiler drain, and gauge.
7. Remove plugs from tappings that will be used for controls and accessories.

Figure 6 Boiler tappings

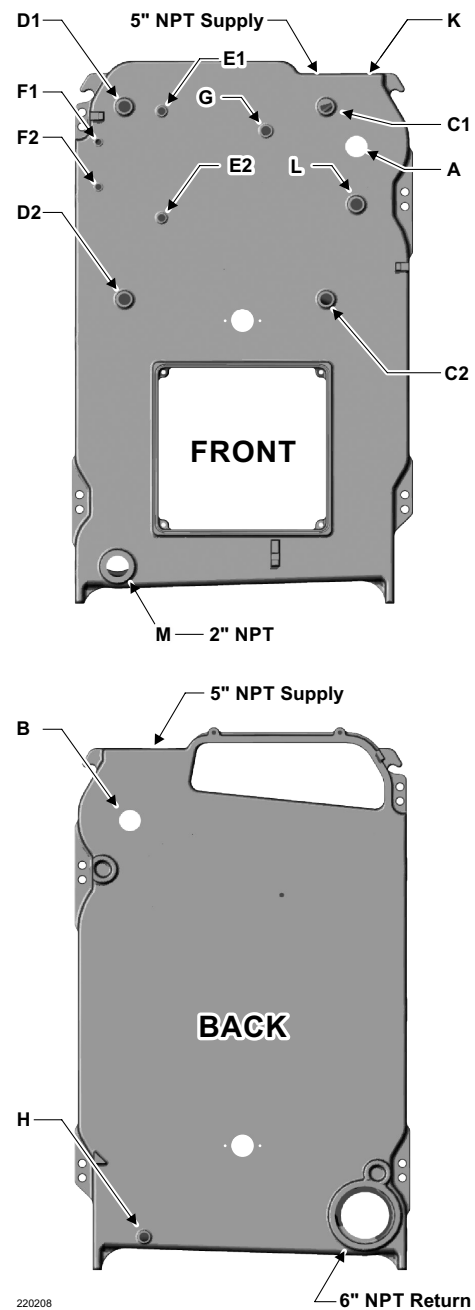

220208

Legend for Figure 6		
Location	Size	Water
A	2"	High limit, Manual reset limit
B	2"	Water relief valve
L	1"	Not used — Plug
C1 & C2	1"	Alternate low water cut-offs
C1		Combination high and low limit control
D1 & D2	1"	Firing rate temperature control (when used) Low water cut-offs
E1 & E2	1/2"	—
F1 & F2	3/8"	—
G	3/4"	Pressure and temperature gauge
H	3/4"	Boiler drain
K	1"	Piping to compression tank or automatic air vent
M	2"	—

Boiler Assembly, continued

Complete the Block Assembly

Install the burner mounting plate onto the front section:

1. Install four 1/2" x 3-1/2" studs to secure the burner mounting plate to the section.
 - a. Thread and lock together two nuts on rounded end of stud. Thread flat end of stud into one of four holes located around opening.
 - b. Remove nuts.
 - c. Repeat steps a and b for remaining studs.
2. Install the burner mounting plate:
 - a. Apply 1/8" continuous bead of sealing rope adhesive in groove around opening in section.
 - b. Position 1/2" sealing rope in groove. Where rope ends meet in the groove, apply a generous amount of adhesive between the rope ends to create a complete seal.
 - c. Hold the rope in place until the adhesive hardens by applying duct tape over the rope to hold it in place. Keep the tape on for at least one hour to ensure a bond between the rope and adhesive. Once the adhesive has hardened, remove the duct tape before installing the burner mounting plate.
 - d. Install the burner mounting plate with the part number and the "UP" positioned at the top. Use 1/2" washers and nuts.

Install observation port assemblies on front and back sections:

3. Install the front observation port assembly:
 - a. Apply 1/8" continuous bead of sealing rope adhesive in groove on observation port.
 - b. Position 3/8" sealing rope in groove.
 - c. Secure assembly to section. Use 10-32 x 3/4" truss-head screws.
4. Repeat step 3 for the back observation port assembly.

Insert HX-baffles:

5. Flue HX-baffles are identified by length. The HX-baffles must be inserted through the clean out openings as shown in Figure 7. The installation sequence is as follows:
 - a. Top position – HX-baffles, 24.0" long.
 - b. Second position – HX-baffles, 26.0" long.
 - c. Third position – HX-baffles, 31.5" long.
 - d. Bottom position – HX-baffles, 34.0" long.

IMPORTANT

Baffles will not physically fit in the row directly above each casting boss.

6. To remove flue HX-baffles to clean the boiler flueways, grab each baffle end with pliers and pull straight out. Clean the HX-baffles before replacing.

Figure 7 HX-baffles installation

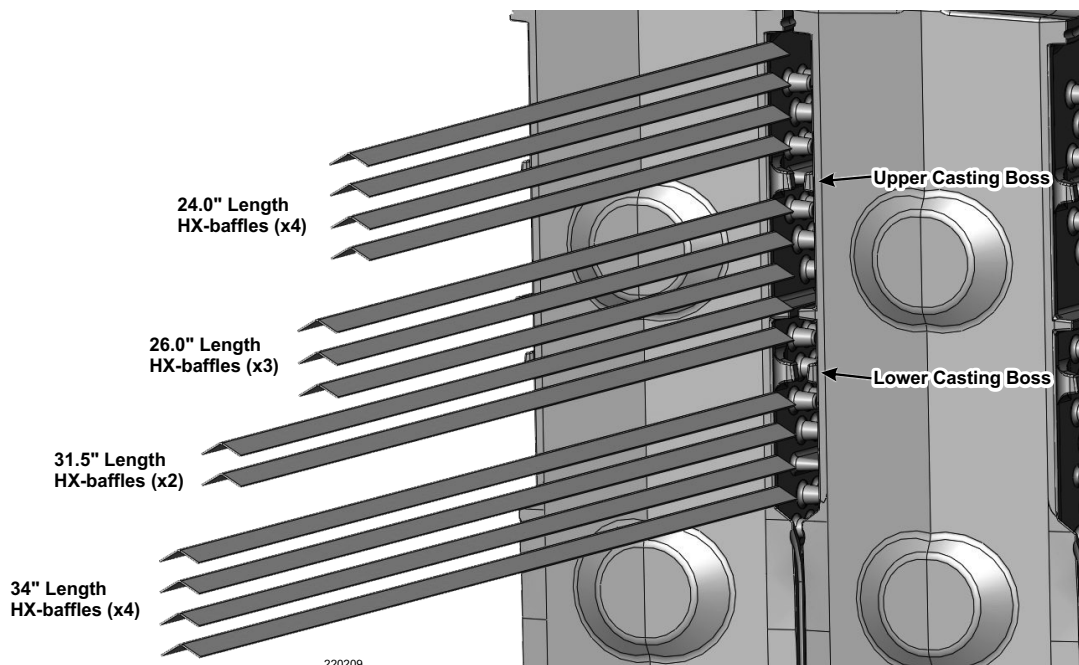

Complete the Block Assembly, continued

Install the clean out plates:

WARNING

Clean out plates must be installed gas-tight to prevent possibility of flue gas leakage and carbon monoxide emissions. Failure to comply can result in severe personal injury or death.

1. Position two 1/4" x 1-3/4" carriage bolts in the clean out opening, between the clean out plate bosses. Secure with washers and nuts. See Figure 8.
2. Place a woven fiberglass gasket over the carriage bolts.
3. Mount the clean out plate over the opening. Secure with nuts and washers.
4. Repeat steps 7-8 for remaining clean out plates.

Install the draft hood collar:

5. Install 1/8" continuous bead of sealing rope adhesive in the groove on the draft hood collar.
6. Position a 1/2" sealing rope in the groove. Where rope ends meet in the groove, apply a generous amount of adhesive between the rope ends to create a complete seal.
7. Hold the rope in place until the adhesive hardens by applying duct tape over the rope to hold it in place. Keep the tape on for at least one hour to ensure a bond between the rope and adhesive. Once the adhesive has hardened, remove the duct tape before installing the draft hood collar.
8. Mount the collar over the flueway outlet on the back section. Secure with 1/2" x 1-1/2" hex head cap screws and washers.

Figure 8 Clean out plate assembly

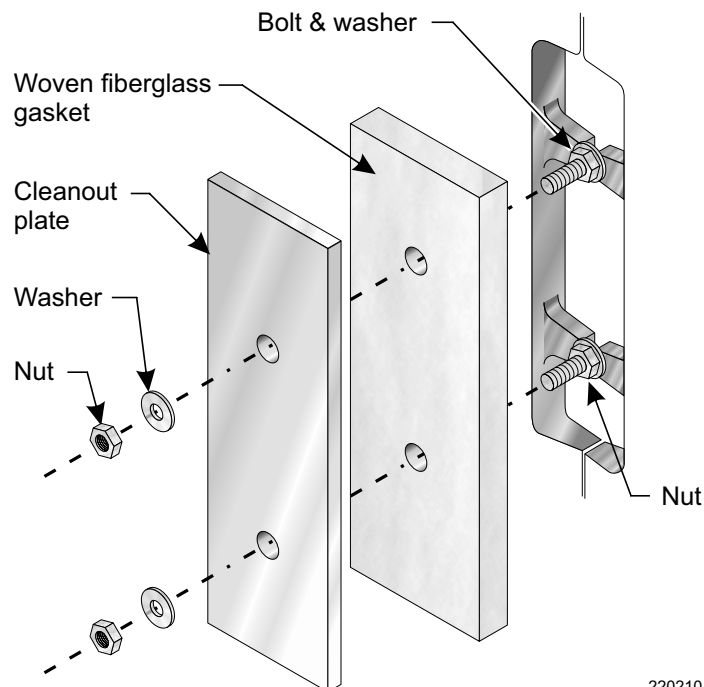

220210

Boiler Assembly, continued

Damper Connector Installation

The 88 Series 3 damper connector includes a 1/2" female threaded boss for condensate drainage of the vent system. This drain boss must be facing directly downward once installed to prevent possible flue gas leakage through the condensate drain system.

Wear protective gloves to prevent injury from sharp edges of the damper connector.

Handle the damper connector with care; it is made with thin gauge material and can be easily dented or damaged before installation.

CAUTION

The damper connector is sharp! Wear cut-resistant gloves during installation to prevent injury.

NOTICE

Handle the damper connector with care to avoid damage.

1. Insert the damper connector gasket from the provided component box into the inner groove of the damper connector. See Figure 9.
2. The outside edge and inner 1/2" lip will hold the gasket in place during installation onto the boiler.
3. Press the gasket down into the groove until the face of the gasket is below the height of the inner lip. Take care when pressing the gasket into the groove due to the sharp edges of the inner lip.
4. Line up the gasket end of the damper connector to the exhaust outlet of the damper casting on the rear of the boiler.
5. Press the damper connector onto the exhaust outlet, ensuring that the inner lip of the damper connector is inside the inner lip of the exhaust outlet.
6. Rotate the damper connector to ensure that the drain boss on the outside of the connector is pointed directly downward towards the floor.
7. While holding the damper connector against the damper casting outlet, use a paint marker or etching tool to mark the four hole locations onto the damper casting through the four equally spaced holes of the damper connector. See Figure 9 and Figure 10.

Figure 9 Damper connector

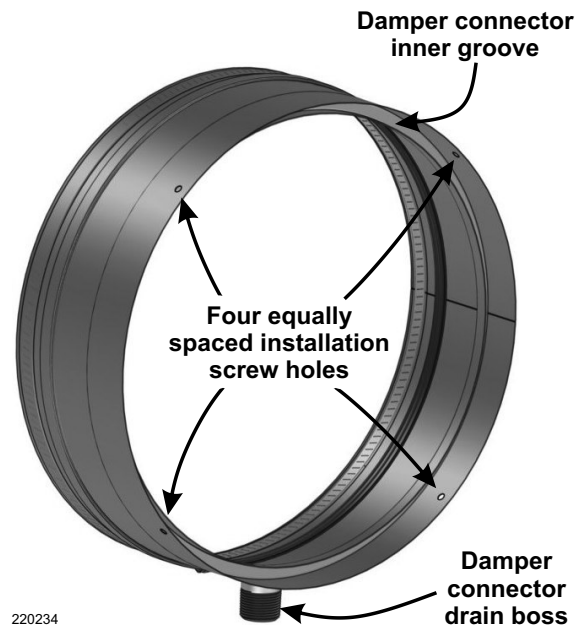
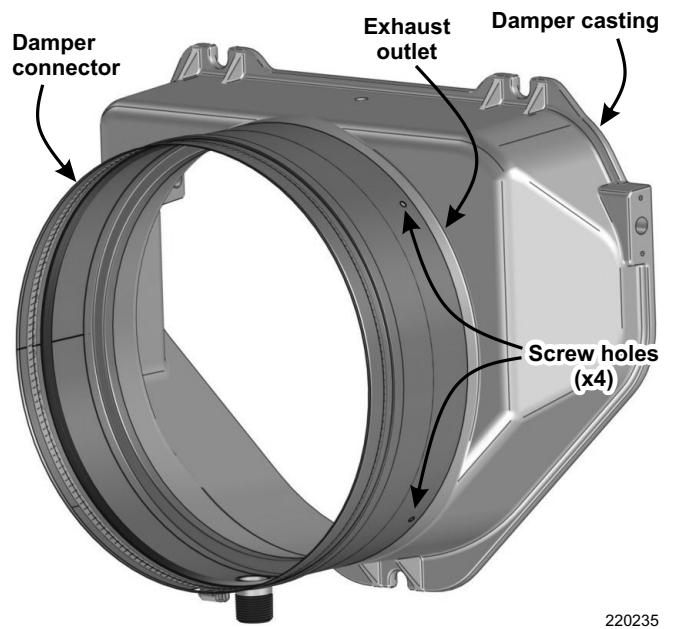

Figure 10 Damper connector on the exhaust outlet



Damper Connector Installation, continued

8. Remove the damper connector and place it in a safe location to ensure no damage to the thin-gauged material
9. Use a 5/32" drill bit to drill four holes into the damper casting at the four marked locations.
10. Return the damper connector to the damper casting exhaust outlet ensuring that the drain boss is pointed directly towards the floor. See Figure 11. The damper connector holes should line up with the marked hole-locations. Verify that the inner lip of the damper connector is inside the inner lip of the damper casting exhaust outlet.

⚠ WARNING

The drain boss on the damper connector must be installed facing directly down to prevent possible flue gas leakage. Failure to comply can result in severe personal injury, death, or substantial property damage.

11. Use a 5/16" nut driver to install four screws from the component box to secure the damper connector to the damper casting outlet.
12. Apply silicone caulk from the component box to both the inside and outside protrusion points of each screw. Ensure an air-tight joint by completely covering both the head and tip of each screw in silicone caulk.

Damper connector installation notes:

- Verify a tight fit between the damper connector and damper casting outlet to ensure gasket compression, which prevents possible flue gas leakage between the boiler and the vent system.
- Verify that the inner lip of the damper connector is inside the inner lip of the exhaust outlet to ensure gasket compression, which prevents possible flue gas leakage between the boiler and the vent system.
- Verify that each installation screw is coated at both ends with silicone caulk, which prevents possible flue gas leakage between the boiler and the vent system.

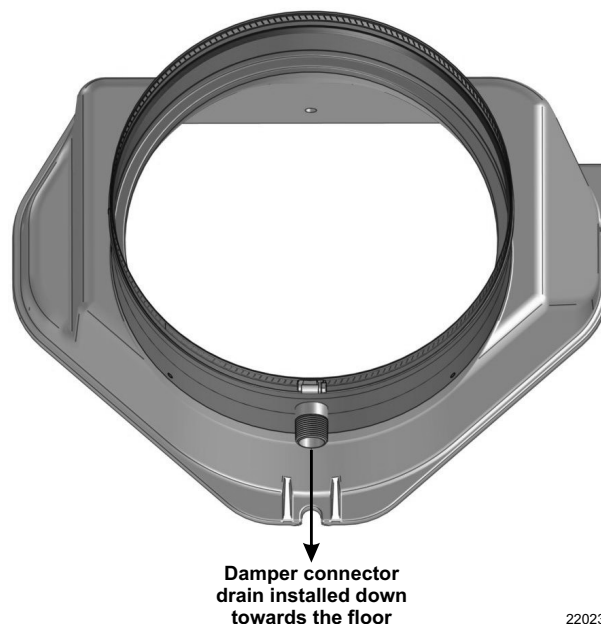
Figure 11 Drain boss location

220236

Connect Water Boiler Piping

General Water Piping Information

1. System water supply and return piping should be installed and piping connections attached to the boiler before erecting jacket or installing controls.
2. Do not pipe in through supply and out through return. This creates reverse water flow through the boiler that must not be used.
3. When installing piping in a system in which return water temperature can drop below 140°F, apply the bypass piping with bypass pump. See [page 21](#) for more information.

Install Water Piping

Install piping for single boilers as shown in Figure 12 and the tables in this section. For multiple boilers, see [Figure 13, page 21](#).

NOTICE

Improperly piped systems or undersized piping can contribute to erratic boiler operation and possible boiler or system damage.

1. Connect supply and return piping.
 - a. Size according to Table 6 for known flow rates at less than 20°F temperature rise through the boiler.
 - b. Size according to Table 7 for unknown flow rates, using 20°F temperature rise through the boiler.

NOTICE

Flow at higher rates than shown in the tables in this manual for given pipe sizes can damage the boiler, resulting in substantial property damage.

- c. Locate the circulator in the supply piping.
- d. For return piping, do not reduce piping until the length is at least 10 times the pipe diameter. For example, a 4-inch return should not be reduced until at least 40 inches from the boiler return tapping.
- e. Install system drain valve close to the boiler in the lowest part of the return piping. ASME minimum size requirements are given in [Table 8, page 21](#).

Figure 12 Typical water boiler piping

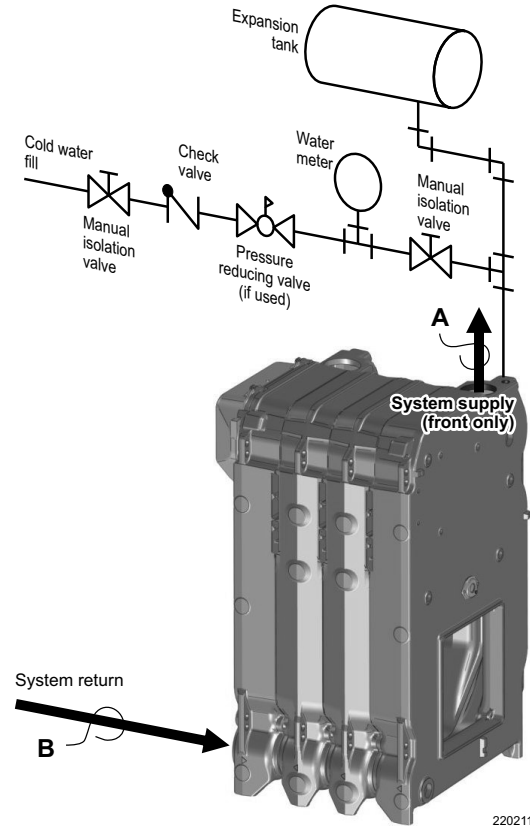

Table 6 Minimum pipe sizes for known flow rates

Water flow rate (GPM)	Supply pipe size (in.) A	Return pipe size (in.) B
Up to 35	2.0	2.0
36–50	2.5	2.5
51–77	3.0	3.0
78–142	4.0	4.0
143–237	5.0	5.0
238–404	6.0*	6.0*

NOTICE

High temperature rise through boiler is permissible when boiler piping connections are sized per this table. Intermittent flow at high velocities may damage any boiler.

**6-inch piping requires nipples and 5" x 6" reducing couplings (provided with 1288 through 1888 boilers only). The total pressure drop through the 1888 boiler using the nipple and reducing coupling will not exceed .25 psi. For smaller boilers, the pressure drop will be less.*

Table 7 Minimum pipe sizes when flow rate is unknown

Boiler Model	Supply pipe size (in.) A	Return pipe size (in.) B
488	3.0	3.0
588 – 788	4.0	4.0
888 – 1188	5.0	5.0
1288 – 1888	6.0*	6.0*

Note: Pipe sizes are based on a 20°F temperature rise through the boiler. For applications with higher flow rates (lower temperature rise), determine the flow rate and use Table 6 to size the piping.

**6-inch piping requires nipples and 5" x 6" reducing couplings (provided with 1288 through 1888 boilers only). The total pressure drop through the 1888 boiler using the nipple and reducing coupling will not exceed .25 psi. For smaller boilers, the pressure drop will be less.*

Install Water Piping, continued

2. Install an expansion tank.
 - a. Closed-type – connect to 1" tapping "K" (see page 15). Use 1" NPT piping. Any horizontal piping must pitch up towards the tank at least 1 inch per 5 feet of piping.
 - Connect cold water fill to expansion tank piping. Figure 12, page 20 shows typical piping when using a closed-type tank.
 - b. Diaphragm-type – Refer to tank manufacturer's literature for location. Install automatic air vent in "K" tapping.
 - c. Recommended valves and water meter, when used, are shown in Figure 12, page 20. Water meter will detect added make-up water, indicating leaks in system.
3. For information on multiple boiler piping, see Figure 13.

Bypass Circulator Sizing

1. Size system circulator as required. Determine GPM and head requirements. See Figure 14 for a piping illustration.
2. Provide a bypass circulator for each boiler. The flow rate for each bypass circulator will be:

$$\text{Flow} = .25 \times (\text{System circulator GPM}) \div (\# \text{ of boilers})$$
3. All circulators must run at the same time.
4. Example: For a 1,000,000 Btuh single boiler, with system temperature drop of 20°F:
 - a. System GPM = $1,000,000 \div 20 \div 500 = 100$ GPM
 - b. Bypass GPM = $.25 \times 100 \text{ GPM} = 25$ GPM
 - c. Determine bypass circuit head loss for pipe size and fittings used.
5. In most applications, a standard booster pump should be adequate.

Table 8 ASME drain valve size

Boiler Model	Minimum Drain Valve Size (inches)
488 – 588	1.00
688 – 1088	1.25
1188 – 1888	1.50

Figure 13 Multiple boiler water piping

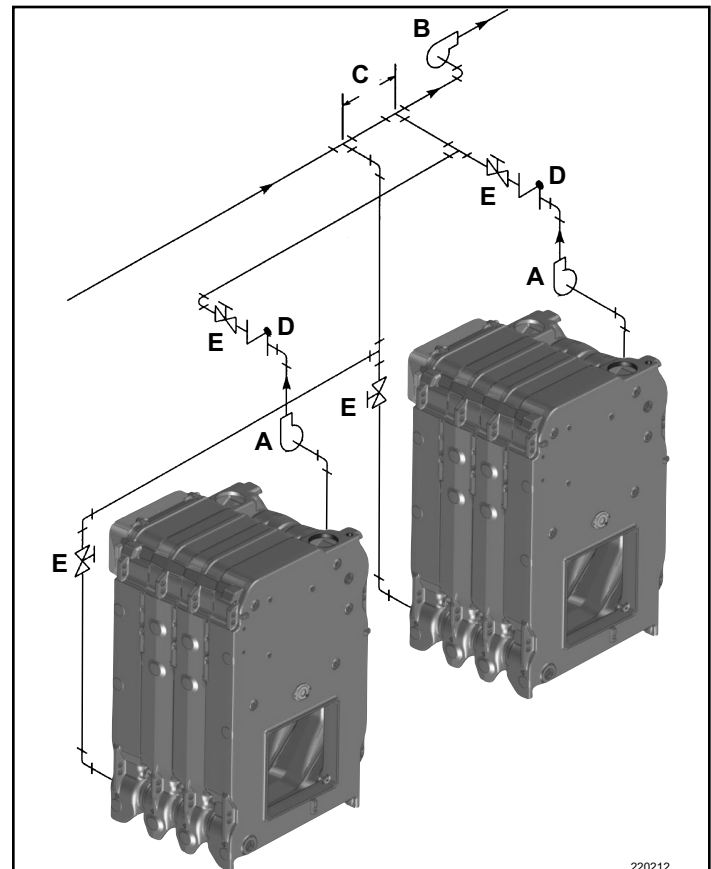

Note: Expansion tanks, relief valves, and other accessories are required, but are omitted from this illustration for simplicity.

- A. Size boiler pump GPM based on the following:
 - Temp rise = Operating limit temp - Return water temp
 - $\text{GPM} = \frac{\text{Boiler Gross Output, Btuh}}{\text{Temperature Rise} \times 500}$
 - Calculate only secondary boiler piping circuit resistance. Allow for head loss through the boiler equal to three 90-degree elbows of secondary pipe size.
 - Operate each boiler with pump with a Weil-McLain boiler control panel.
 - Size secondary boiler circuit piping using the flow rate ranges given in Table 6, page 20.
- B. The primary pump GPM and head calculation should not include secondary boiler circuits. The primary pump can operate continuously during the heating season.
- C. Connection to primary circuit – space 12" maximum or as close as practical.
- D. Check valve.
- E. Hand valve.

Figure 14 Bypass piping for return water less than 140°F

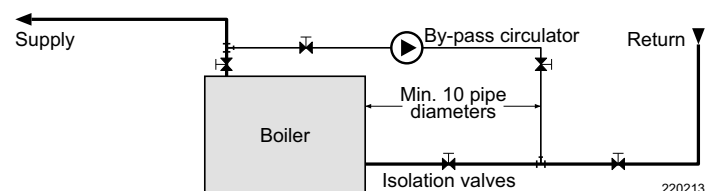

Install the Jacket

Preparing for Jacket Installation

WARNING

The boiler contains ceramic fiber and fiberglass materials. Use care when handling these materials per instructions on page 49 of this manual. Failure to comply could result in severe personal injury.

1. These parts must be on boiler:
 - a. Plugs for unused tapings
 - b. Supply and return piping and steam supply header
 - c. Clean out plates
 - d. Tankless heaters (when used), tankless heater cover plates (when used), tankless heater piping (when used)
 - e. Flue damper assembly
 - f. Observation port assemblies
2. These parts may be on boiler:
 - a. Burner mounting plate
3. These parts must be off boiler:
 - a. Water or steam gauge
 - b. Limit control and low water cutoff
 - c. Gauge glass and gauge glass cocks, tri-cocks
 - d. Drain cock

Removal of Jacket Parts

1. Locate the jacket cartons.
2. Remove jacket parts from the cartons as needed. Leave the parts in the cartons until needed for installation to avoid damage.
3. Jacket parts are in the boxes listed in Table 9.

Install Support Brackets and Channels

1. Place upper and lower support brackets over draw rods as shown in [Figure 15, page 23](#). Place the brackets on the sections as given in Table 10. Sections are numbered from front to back.
2. Fasten each bracket loosely using two 5/8" nuts screwed onto the ends of the tie rods as shown.

IMPORTANT

Models 488 to 988 do not require lower support brackets; only upper brackets are required.

Table 9 Box labels per jacket parts

Part	Box Label Descriptions
Jacket screws (in jacket corner boxes)	Included in CRNR boxes
Jacket support brackets and hex nuts	BKT
Jacket side support channels, upper and lower	Included in TRM/CHNL boxes
Jacket front/rear support channels, upper and lower	COM
Jacket front panel	PNL-F
Jacket back panel	PNL-B
Jacket side and top panels	L / R / T
Jacket corners	CRNR
Jacket trim	TRM/CHNL

Table 10 Support bracket placement

Boiler Model	Upper brackets on sections:	Lower brackets on sections:
488	2, 3	None
588	2, 4	None
688	2, 5	None
788	2, 6	None
888	3, 6	None
988	2, 5, 8	None
1088	3, 6, 9	6
1188	3, 6, 9	6
1288	3, 7, 10	7
1388	3, 7, 11	7
1488	3, 7, 10, 13	7
1588	2, 5, 8, 11, 14	8
1688	2, 5, 9, 12, 15	9
1788	2, 5, 9, 13, 16	9
1888	2, 6, 10, 14, 17	10

Table 11 Side channel lengths

Boiler Model	Upper Channel Lengths (inches)		Lower Channel Lengths (inches)	
	A	B	C	D
488	30	NA	26	NA
588	38	NA	34	NA
688	46	NA	42	NA
788	54	NA	50	NA
888	62	NA	58	NA
988	35	35	66	NA
1088	43	35	40	34
1188	43	43	40	42
1288	51	43	48	42
1388	51	51	48	50
1488	51	59	48	58
1588	59	59	56	58
1688	67	59	64	58
1788	67	67	64	66
1888	71	71	72	66

IMPORTANT

Fasten all nuts and screws loosely during assembly to allow adjustment after all jacket frame parts are installed.



Install Support Brackets and Channels, cont.

3. Attach the upper channels to the upper supports as shown in images 1 and 2 in Figure 15. Models 988 and larger have two-piece channels.
4. Attach the four jacket corners to the upper channels as shown in image 6 in Figure 15.
5. Attach the lower side, front, and rear channels to the jacket corners as shown in images 4 and 5 in Figure 15. Models 1088 and larger have two-piece side channels.

Figure 15 Installing jacket support brackets, support channels, and corners (some components omitted for clarity)

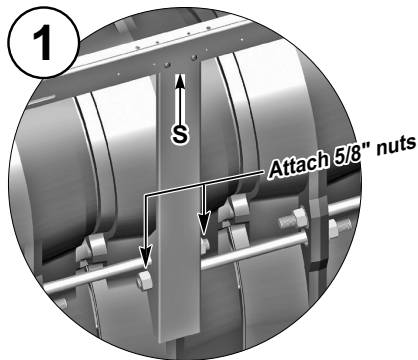

Upper right support bracket

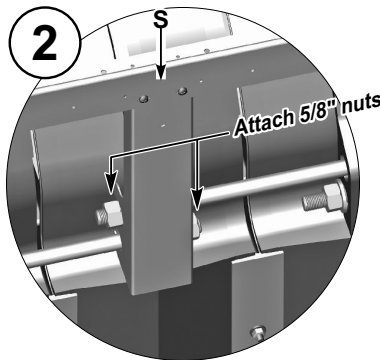

Upper left support bracket

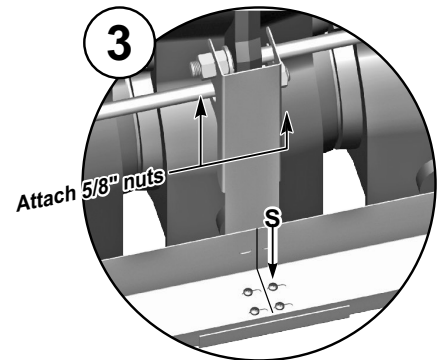

Lower support brackets

S = Insert #10 x 1/2" Phillips pan head screws
 A, B = Side channel pieces, front and rear

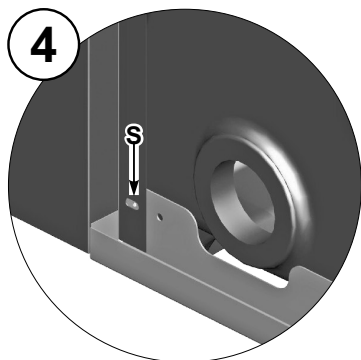
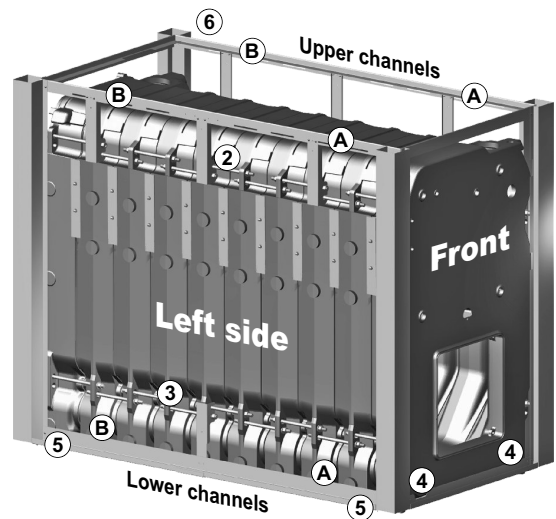
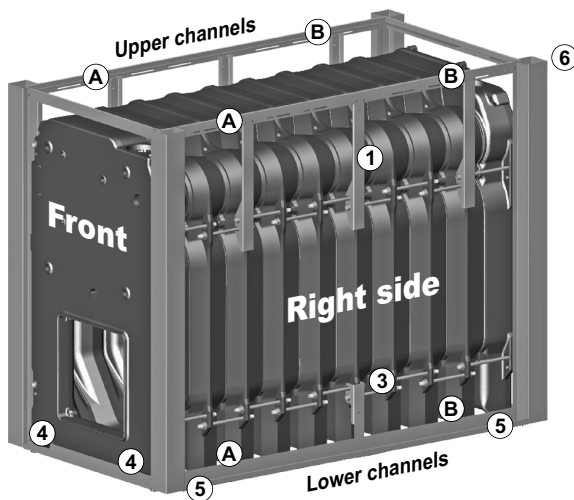

Corner attachments to lower front and rear channels

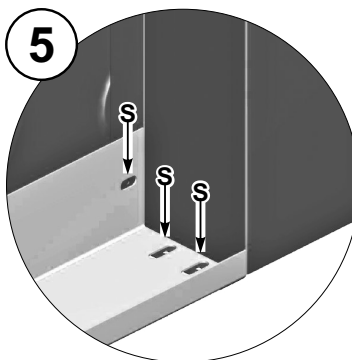

Corner attachments to lower channels

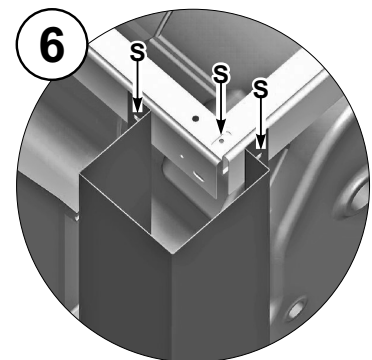

Corner attachments to upper channels

220214

Install the Jacket, continued

Install the Jacket Front and Back Panels

1. Slide the jacket front and back panels down over the top channels and into the bottom channels as shown in Figure 16.
2. Slide the upper and lower channels as needed to square up the fit.

Install Jacket Side Panels

1. Remove jacket side panels from cartons.
2. Before installing side panels, square up the jacket support rails.
3. Place any of the jacket side panels on the rails as shown in Figure 16.
4. Align the side panel against the jacket corner panel.
5. Push or pull on the upper and lower channels until the fit-up of the side panel, corner panel and channels is square.
6. Place a jacket top panel in position against the jacket front panel to ensure the top alignment is square. Adjust the jacket support rails forward or backward if needed for square alignment.
7. Tighten the 5/8-inch nuts on the upper (and lower) support brackets.
8. Tighten the screws securing the upper and lower rails to the support brackets.
9. Tighten the screws securing the front and back panels to the rails.
10. Apply all jacket side panels in the order shown in [Figure 17, page 25](#).
 - a. Remove jacket knockouts as required for tankless heaters and tankless heater openings.
 - b. Note that panel sequence is not important for boilers not equipped with tankless heater intermediate sections.

Figure 16 Jacket front, rear, and side panels installation

When servicing:
Lift trim up to
access panels
(replace after
servicing)

Jacket panel flange fits
over upper rail

Slide panel down to install.
Slide side panel up to remove

Flanges of lower channels
hold jacket panels in place

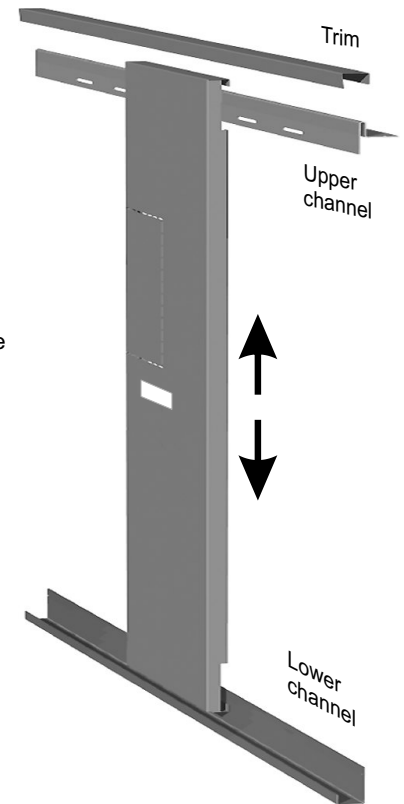

220215

Figure 17 Jacket side panel placement

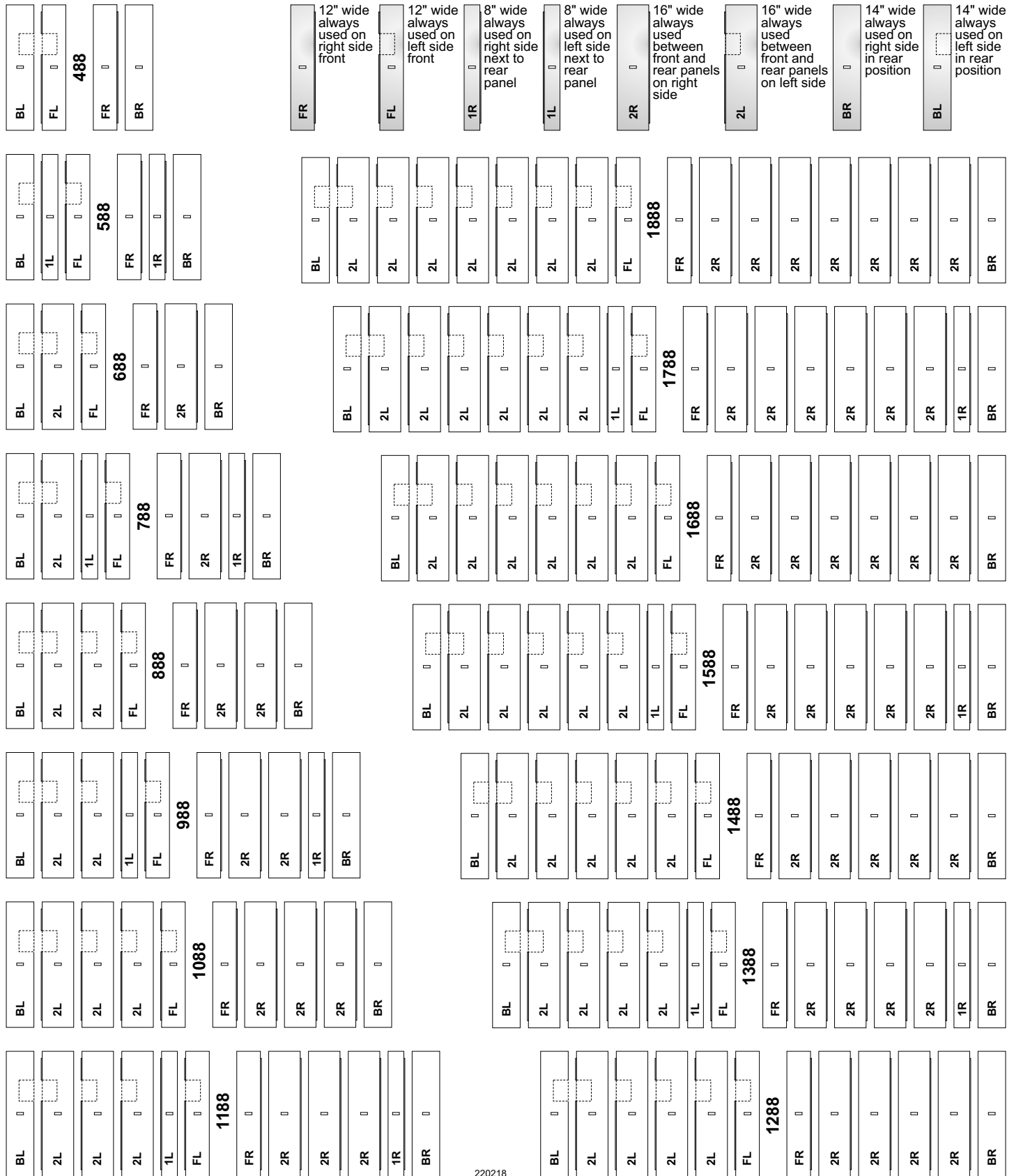

220218



Install the Jacket, continued

Install Top Insulation

⚠WARNING

The boiler contains ceramic fiber and fiberglass materials. Use care when handling these materials per instructions on [page 49](#) of this manual. Failure to comply could result in severe personal injury.

Refer to Figure 18 for the following instructions.

1. Cut insulation to length.
2. Center and align front and back of insulation to outside edges of front and back sections.
3. Center insulation on top of sections. Fold sides of insulation until the folded sides compress between section and top mounting brackets.

Install Jacket Top Panels

Place jacket top panels as shown in [Figure 20, page 27](#). Remove knockouts for riser pipes. Air bleed piping (front section) using tin snips.

Install Jacket Trim

Press jacket trim down over the front and side jacket panels as shown in [Figure 19](#).

Figure 18 Top insulation installation

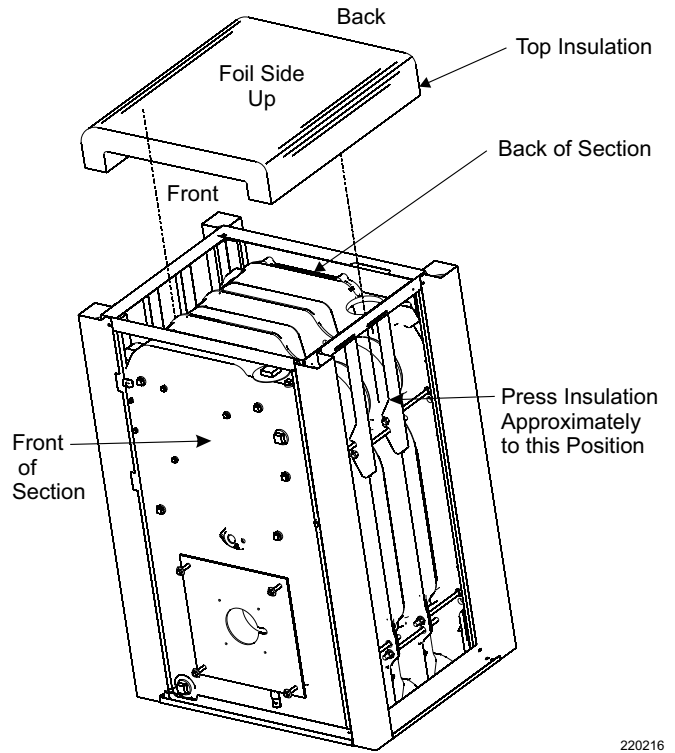

220216

Figure 19 Jacket trim placement

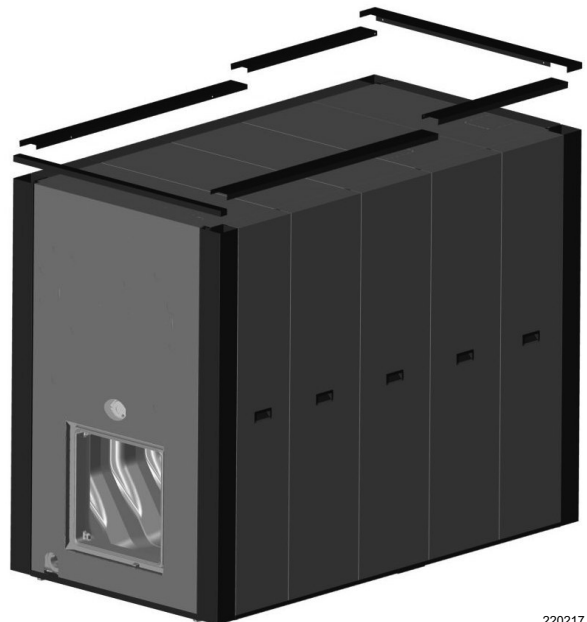

220217

Figure 20 Jacket top panel placement

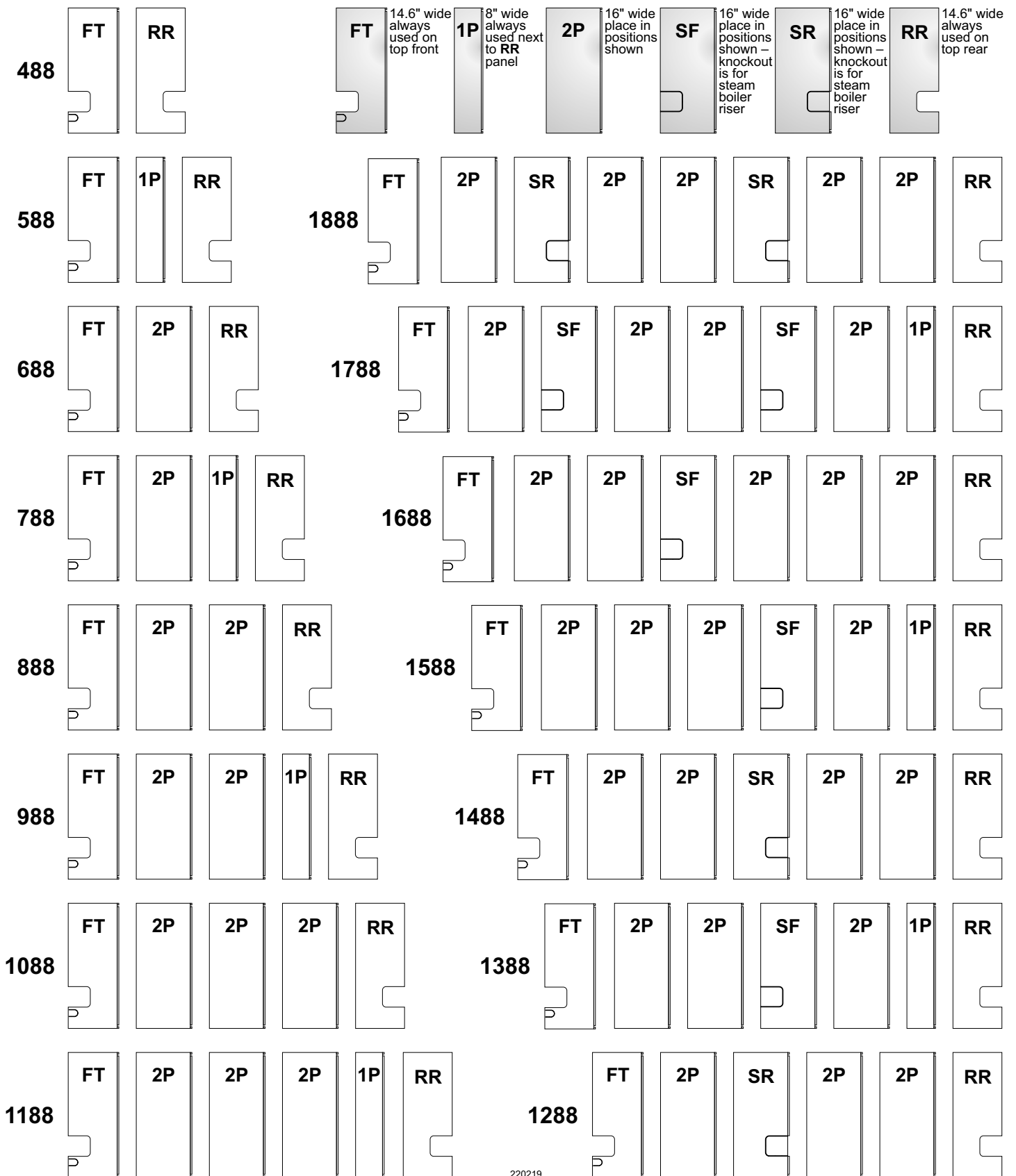

2

Tankless Heaters

Hot Water Precautions

⚠ DANGER

Hot water can scald! Water heated to a temperature suitable for clothes washing, dish washing, and other sanitizing needs will scald and cause injury (Figure 21). If anyone using hot water in the building are children, elderly, infirm or physically handicapped persons, or if state laws or local codes require certain water temperatures at hot water faucets, take special precautions as listed below.

The Consumer Product Safety Commission and some states recommend domestic hot water temperature of 130°F or less.

When installing an automatic mixing valve, selection and installation must comply with valve manufacturer's recommendations and instructions.

Special precautions:

- Install an automatic mixing valve set according to the standards above.
- Use the lowest practical temperature setting.
- Check the water temperature immediately after the first heating cycle, and again after any adjustment is made.

Piping Tankless Heaters

1. Size piping no smaller than heater inlet and outlet.
2. Automatic mixing valve must be installed. See Figure 22. Follow the manufacturer's instructions.
3. Flow regulating valve must be installed and sized according to continuous draw of heater. See Table 12. Follow manufacturer's instructions to install.
4. Operating control with small adjustable differential scale is recommended; install in the temperature control tapping in the heater plate.
5. Multiple tankless heaters (see Figure 22):
 - a. Use a cold water supply header with individual risers to each heater.
 - b. Use a hot water outlet header with individual risers to each heater.
 - c. Size headers by increasing one pipe size for each additional heater.
 - d. Do not pipe multiple heaters in series.
6. In hard water areas, soften cold domestic water supply to heaters to prevent lime build-up.

Figure 21 Hot water danger



Figure 22 Tankless heater piping

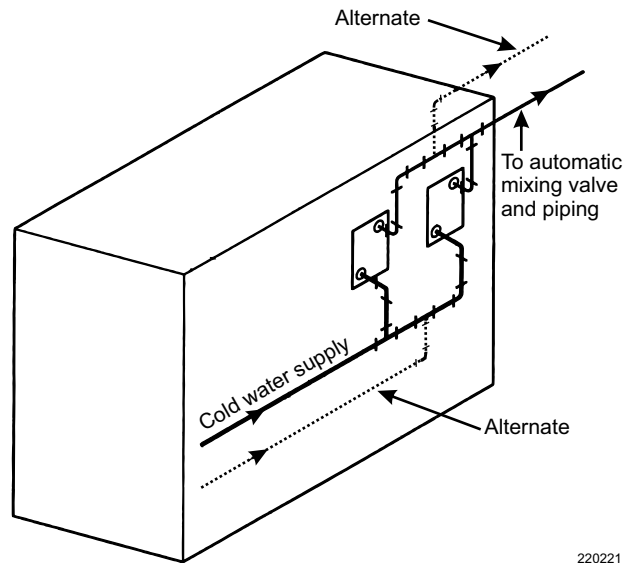

Table 12 Tankless heater ratings

Heater Number	Intermittent Draw* (GPM)	Continuous Draw* (GPM)	Inlet and Outlet Tappings
820	8.5	8.0	.75"

*Based on continuous draw with no recovery period. GPM is based on 40-140°F domestic hot water with boiler water at 200°F.



Tankless water heaters for the 88 boilers have been tested and certified by CSA Group (certificate # 2552127).



Water Boiler Controls

Installing the Controls

1. Install furnished controls per Figure 23 and Table 13.

⚠WARNING

Failure to properly install, pipe, and wire boiler controls can result in severe personal injury, death, or substantial property damage that is not covered by boiler warranty.

2. Relief valve must be installed with the spindle in the vertical position. Use the fittings provided with the boiler. Do not make any other connection in that piping.

⚠WARNING

Relief valve discharge line must be piped using rigid material suitable for 375°F, threaded on one end, and near the floor close to the drain to eliminate potential of severe burns. Do not pipe to any area where freezing could occur. Do not plug, valve, or place any obstruction in discharge line. Failure to comply can result in severe personal injury, death, or substantial property damage.

3. Install a low water cutoff (LWCO) when required.
 - a. An LWCO must be installed if the boiler is located above radiation level.
 - b. An LWCO may be required on water boilers by certain state, local or territorial codes or insurance companies.
 - c. Install an LWCO designed for water installations where shown in Figure 23 and Table 13.
4. If installation is to comply with ASME installation requirements, an additional high temperature limit is needed; purchase and install in the supply line between the boiler and isolation valve or in the 'A' tapping.
5. Dual limit control settings.
 - a. Low – set according to design requirements.
 - b. High – at least 20° higher than low limit, 240°F maximum.
6. Install optional controls per control manufacturer's instructions.

Figure 23 Water control locations

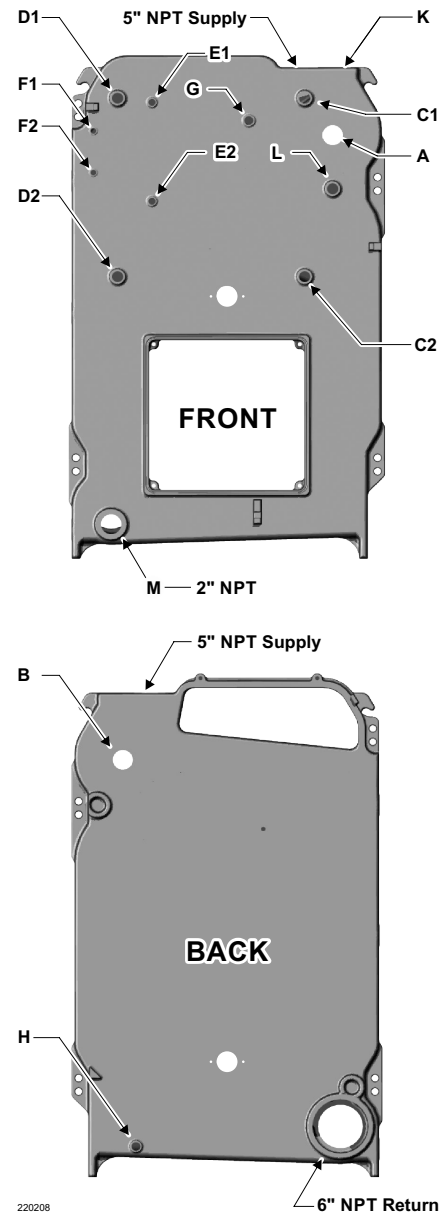

Table 13 Water control tappings

Location	Size	Function
A	2"	High limit Manual reset limit
B	2"	Water relief valve
L	1"	Not used — plug
C1 & C2	1"	Alternate low water cut-offs
C1		Combination high and low limit control
D1 & D2	1"	Firing rate temperature control (when used) Low water cut-offs
E1 & E2	½"	—
F1 & F2	3/8"	—
G	¾"	Pressure and temperature gauge
H	¾"	Boiler drain
K	1"	Piping to compression tank or automatic air vent
M	2"	Drain

Condensate Trap

Condensate Drain Trap Construction

⚠WARNING

A condensate drain trap **MUST** be in place to prevent possible flue gas leakage through the condensate drain system. Failure to comply can result in severe personal injury, death, or substantial property damage.

⚠WARNING

Category IV boiler and vent installations require a condensate trap that will maintain a trap in all cases with a positive pressure in the vent system, such as a check valve in the trap system. Failure to comply can cause flue gas leakage, which can result in personal injury, death, or substantial property damage.

The trap shown in Figure 24 will work for Category II systems. Category IV systems or positive pressure systems must incorporate a method to prevent flue gas leakage in case of a dry trap.

Install a condensate trap onto the boiler. Trap components are not included with the boiler. The damper connector includes a 1/2" female threaded boss for condensate drainage of the vent system.

1. Verify that the threaded boss on the damper connector is pointed directly downwards toward the floor.
2. Install a 1/2" NPT male threaded CPVC connector into the female threaded boss on the damper connector.
3. A standard drain trap design for boilers is shown in Figure 24. Typical trap component sizes are approximately one 1/2" threaded connector, one 1/2" elbows fitting connectors, one 1/2" "T"-fitting connector, and two 1/2" straight pieces.
4. Create a minimum trap height of 3".

Figure 24 Condensate trap

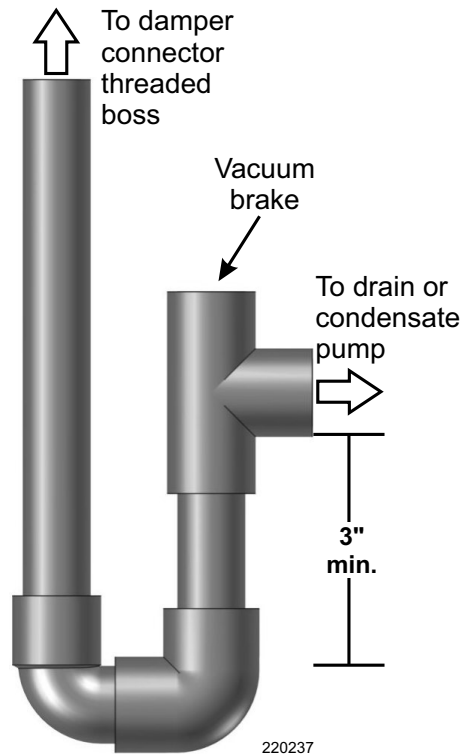

5. Use appropriate connection methods (cement and primer) between CPVC joints to create water-tight connections.
6. Condensate trap must be filled with condensate (or water) before starting the boiler to prevent possible flue gas leakage through the condensate drain system.

⚠WARNING

Ensure the condensate trap has condensate or water before starting the boiler. Failure to comply can cause flue gas leakage, which can result in personal injury, death, or substantial property damage.

Condensate Drain Trap Construction, cont.**Condensate drain trap notes:**

- Route condensate from the trap to a drain or condensate pump.
- Use materials approved by the authority having jurisdiction.
- In the absence of other authority, CPVC pipe must comply with ASTM D1785, F441 or D2665.
- Cement and primer must comply with ASTM D2564 or F493.
- The condensate line must remain unobstructed, allowing free flow of condensate. If condensate is allowed to freeze in the line or if the line is obstructed in any other manor, condensate can back up into the boiler, eventually leading to boiler lockout.
- Condensate from the boiler will be slightly acidic (typically with a pH from 3.2 to 4.5). Weil-McLain recommends the use of a condensate neutralizer with the condensate drain. Follow local codes to determine if a neutralizing filter is required.
- If installing a condensate pump, select one approved for use with condensing boilers and furnaces. The pump should have an overflow switch to prevent property damage from condensate spillage. Provide an external power source for the condensate pump.

Figure 25 Condensate trap on the damper connector

Commonwealth of Massachusetts Installations

Commonwealth of Massachusetts — When the boiler is installed within the Commonwealth of Massachusetts, the boiler must be installed by a licensed plumber or gas fitter. Read and comply with the instructions below.

1. **REQUIREMENTS:** For all sidewall horizontally-vented gas-fueled equipment installed in every dwelling, building or structure used in whole or in part for residential purposes, including those owned or operated by the Commonwealth and where the side wall exhaust vent termination is less than 7 feet above finished grade in the area of the venting, including but not limited to decks and porches, the following requirements shall be satisfied:
 - a. **INSTALLATION OF CARBON MONOXIDE DETECTORS.** At the time of installation of the side wall horizontal vented gas fueled equipment, the installing plumber or gas fitter shall observe that a hard wired carbon monoxide detector with an alarm and battery back-up is installed on the floor level where the gas equipment is to be installed. In addition, the installing plumber or gas fitter shall observe that a battery operated or hard wired carbon monoxide detector with an alarm is installed on each additional level of the dwelling, building or structure served by the side wall horizontal vented gas fueled equipment. It shall be the responsibility of the property owner to secure the services of qualified licensed professionals for the installation of hard wired carbon monoxide detectors.
 - In the event that the side wall horizontally vented gas fueled equipment is installed in a crawl space or an attic, the hard wired carbon monoxide detector with alarm and battery back-up may be installed on the next adjacent floor level.
 - In the event that the requirements of this subdivision can not be met at the time of completion of installation, the owner shall have a period of thirty (30) days to comply with the above requirements; provided, however, that during said thirty (30) day period, a battery operated carbon monoxide detector with an alarm shall be installed.
 - b. **APPROVED CARBON MONOXIDE DETECTORS.** Each carbon monoxide detector as required in accordance with the above provisions shall comply with NFPA 720 and be ANSI/UL 2034 listed and IAS certified.
 - c. **SIGNAGE.** A metal or plastic identification plate shall be permanently mounted to the exterior of the building at a minimum height of 8 feet above grade directly in line with the exhaust vent terminal for the horizontally vented gas fueled heating appliance or equipment. The sign shall read, in print size no less than one-half (1/2) inch in size, "GAS VENT DIRECTLY BELOW. KEEP CLEAR OF ALL OBSTRUCTIONS."
 - d. **INSPECTION.** The state or local gas inspector of the side wall horizontally vented gas fueled equipment shall not approve the installation unless, upon inspection, the inspector observes carbon monoxide detectors and signage installed in accordance with the provisions of 248 CMR 5.08(2)(a) 1 through 4.
2. **EXEMPTIONS:** The following equipment is exempt from 248 CMR 5.08(2)(a)1 through 4:
 - a. The equipment listed in Chapter 10 entitled "Equipment Not Required To Be Vented" in the most current edition of NFPA 54 as adopted by the Board; and
 - b. Product Approved side wall horizontally vented gas fueled equipment installed in a room or structure separate from the dwelling, building or structure used in whole or in part for residential purposes.
3. **MANUFACTURER REQUIREMENTS — GAS EQUIPMENT VENTING SYSTEM PROVIDED.** When the manufacturer of Product Approved side wall horizontally vented gas equipment provides a venting system design or venting system components with the equipment, the instructions provided by the manufacturer for installation of the equipment and the venting system shall include:
 - a. Detailed instructions for the installation of the venting system design or the venting system components; and
 - b. A complete parts list for the venting system design or venting system.
4. **MANUFACTURER REQUIREMENTS — GAS EQUIPMENT VENTING SYSTEM NOT PROVIDED.** When the manufacturer of a Product Approved side wall horizontally vented gas fueled equipment does not provide the parts for venting the flue gases, but identifies "special venting systems", the following requirements shall be satisfied by the manufacturer:
 - a. The referenced "special venting system" instructions shall be included with the appliance or equipment installation instructions; and
 - b. The "special venting systems" shall be Product Approved by the Board, and the instructions for that system shall include a parts list and detailed installation instructions.
5. **PLASTIC VENTING SYSTEMS.** The only plastic piping which may be used for venting appliances shall be:
 - a. Allowed by the appliance manufacturer.
 - b. Listed to a national/international standard for plastic venting systems.
 - c. Product-accepted for that purpose by the board.
6. **INSTALLATION INSTRUCTIONS.** A copy of all installation instructions for all Product Approved side wall horizontally vented gas fueled equipment, all venting instructions, all parts lists for venting instructions, and/or all venting design instructions shall remain with the appliance or equipment at the completion of the installation.

Venting and Combustion Air - General

Code Compliance

Venting and combustion air piping installations must provide provisions in accordance with the section, "Air for Combustion and Ventilation," of the National Fuel Gas Code – ANSI Z223.1/NFPA 54, latest edition, and applicable provisions of the local building codes.

⚠ DANGER

Inspect finished vent piping thoroughly to ensure all are airtight and comply with instructions in this manual and applicable codes. Verify that all air openings are correctly sized, unobstructed, and free of airborne contaminants. Failure to provide a properly installed vent system will cause severe personal injury or death.

Combustion Air Contamination

Provide combustion air openings or air inlet piping as described in this manual. See Table 14 for products and areas that may cause contaminated combustion air.

Dual Fuel Venting Requirements

⚠ WARNING

A venting system in a Dual Fuel installation should meet the requirements for both fuels. Failure to follow the vent system requirements specified in this manual can result in severe personal injury, death, or substantial property damage.

When the installation calls for a Dual Fuel burner, Gas and Oil, the vent system must be designed with the specific requirements of both fuels as specified in the Gas and Oil sections on [pages 37-42](#).

The vent system must be certified to both UL 1738 and UL 641, and any local codes having jurisdiction. Contact your preferred vent supplier for available products.

Table 14 Corrosive contaminants and sources

Products to avoid
Spray cans containing chloro/fluorocarbons
Permanent wave solutions
Chlorinated waxes and cleaners
Chlorine-based swimming pool chemicals
Calcium chloride used for thawing
Sodium chloride used for water softening
Refrigerant leaks
Paint or varnish removers
Hydrochloric acid and muriatic acid
Cements and glues
Anti-static fabric softeners used in clothes dryers
Chlorine-type bleaches, detergents, and cleaning solvents
Adhesives used to fasten building products and other similar products
Excessive dust and dirt

Areas likely to have contaminants
Laundry and dry cleaning areas and establishments
Swimming pools
Metal fabrication plants
Beauty shops
Refrigeration repair shops
Photo processing plants
Auto body shops
Plastic manufacturing plants
Furniture refinishing areas and establishments
New building construction
Remodeling areas
Garages with workshops

Venting and Combustion Air Options

Existing Category I Vent System

▲WARNING

Follow all venting and piping instructions. Failure to follow all instructions can cause flue gas spillage and carbon monoxide emissions, which can result in severe personal injury or death.

For additional venting requirements, see [page 39](#).

Removal of the previous boiler may cause an issue for the appliances that remain on the old common vent as the vent may be too large. The following test is intended to check for proper operation of the appliances remaining on the old common vent system.

Test Procedure for Existing Vent System

Perform this test when removing a boiler from the common venting system. The following steps shall be followed with each appliance remaining connected to the common venting system. Test each appliance separately while in operation. Ensure all other appliances connected to the common vent are not in operation. Seal any unused openings in the common venting system before proceeding with the test.

1. Visually inspect the venting system for proper size and horizontal pitch. Ensure there is no blockage, restriction, leakage, corrosion, or other deficiency that can cause an unsafe condition.
2. Close all building doors and windows as practical. Close all doors between the location of the appliances connected to the common venting system and other spaces of the building.

3. Turn on the clothes dryer and any other appliance not connected to the common venting system. Turn on all exhaust fans, except for a summer exhaust fan, and operate at maximum speed. Exhaust fans include range hoods and bathroom fans. Close fireplace dampers.
4. Place the appliance being inspected into operation. Follow the lighting instructions. Adjust the thermostat so the appliance will operate continuously.
5. Test for spillage at the draft hood relief opening after five minutes of main burner operation. Use the flame of a match or candle, or smoke from a smoke stick.
6. After it has been determined that each appliance remaining connected to the common venting system properly vents when tested as outlined here, return doors, windows, exhaust fans, fireplace dampers, and any other gas-burning appliance to their previous conditions of use.

Correct any improper operation of the common venting system so the installation conforms with the National Fuel Gas Code – ANSI Z223.1/NFPA 54, latest edition. When resizing any portion of the common venting system, approach the minimum size as determined using the appropriate tables in part 11 of the National Fuel Gas Code – ANSI Z223.1/NFPA 54, latest edition.

Room Air Openings

Combustion Air Provision

The 88 commercial boiler can use inside air if no contaminants are present in the boiler space. If contaminants are likely to be present, install the boiler as a direct vent appliance. Use the appropriate vent instructions in this manual.

The boiler room must be fitted with combustion air openings large enough to provide air for all appliances in the room. Use the following information to size the openings. Ensure the installation complies with all applicable codes and standards.

Sizing Combustion Air Openings

Air openings provide ventilation to prevent overheating of the boiler controls and boiler space. Air is also needed for other appliances located in the same space. Use the information in [Figure 26, page 36](#) for air openings.

⚠WARNING

Air openings must be sized to handle all appliances and air movers, such as exhaust fans, using the air supply. Failure to comply can result in severe personal injury, death, or substantial property damage.

The sizing given in [Figure 26, page 36](#) is based on the National Fuel Gas Code – ANSI Z223.1/NFPA 54, latest edition. The sizing allows adequate air openings for gravity-vented gas appliances (Category I), in addition to the needs for the 88 boiler, provided the boiler room is not subjected to negative pressure due to exhaust fans or other mechanical ventilation devices.

The 88 commercial boiler has varying requirements for combustion and ventilation air, reflected by the special sizing instructions given in this manual. Refer to the National Fuel Gas Code for dealing with other conditions.

Free area and louvers

The free area of openings means the area after reduction for any installed louvers or grilles. Be sure to consider this reduction when sizing the air opening.

Special Considerations

Tight construction

The National Fuel Gas Code – ANSI Z223.1/NFPA 54, latest edition defines unusually tight construction where all of the following is true:

1. Walls and ceilings exposed to the outside atmosphere have a continuous water vapor retarder with a rating of 1 perm or less with openings fitted with gaskets.
2. Weather-stripping has been added on windows and doors that are capable of being opened.
3. Caulking or sealants are applied to areas such as joints around windows and door frames, between sole plates and floors, between wall-ceiling joints, between wall panels, at penetrations for plumbing, electrical, and gas lines, and in other openings.

For buildings with such construction, provide air openings into the building from outside. Size the openings per the appropriate condition in [Figure 26, page 36](#) if appliances are to use inside air for combustion and ventilation.

Exhaust fans and movers

The appliance space must never be under a negative pressure. Always provide air openings sized to the dimensions required for the firing rate of all appliances, with the ability to handle the air movement rate of the exhaust fans or air movers using air from the building or space.

Room Air Openings, continued

Figure 26 Minimum combustion air openings

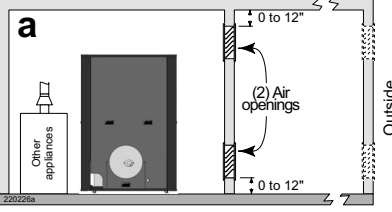
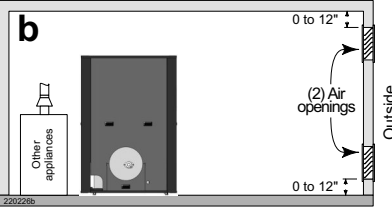
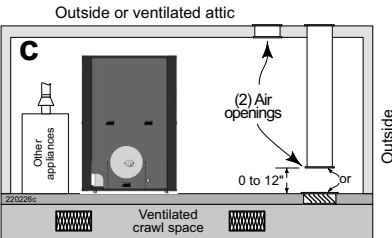
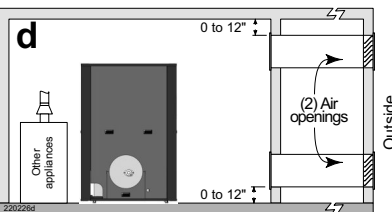
<p>Air openings The required air opening sizes below are FREE AREA, after reduction for louver obstruction. See the important below for large spaces.</p>	<p>88 boiler WITH other appliances in the same room</p>	<p>88 boiler WITHOUT other appliances in the same room</p>
	<p>Two openings, each at least: 1 square inch per 1,000 Btuh of all appliances in the room, but not less than 100 in².</p>	<p>Two openings, each at least: 1 square inch per 1,000 Btuh of all appliances in the room, but not less than 100 in².</p>
	<p>Two openings, each at least: 1 square inch per 2,000 Btuh of all appliances in the room -OR- One opening* at least: 1 square inch per 3,000 Btuh of all appliances in the room</p>	<p>Two openings, each at least: 1 square inch per 2,000 Btuh of all appliances in the room -OR- One opening* at least: 1 square inch per 3,000 Btuh of all appliances in the room</p>
	<p>Two openings, each at least: 1 square inch per 4,000 Btuh of all appliances in the room -OR- One opening* at least: 1 square inch per 3,000 Btuh of all appliances in the room</p>	<p>Two openings, each at least: 1 square inch per 4,000 Btuh of all appliances in the room -OR- One opening* at least: 1 square inch per 3,000 Btuh of all appliances in the room</p>
	<p>Two openings, each at least: 1 square inch per 2,000 Btuh of all appliances in the room -OR- One opening* at least: 1 square inch per 3,000 Btuh of all appliances in the room</p>	<p>Two openings, each at least: 1 square inch per 2,000 Btuh of all appliances in the room -OR- One opening* at least: 1 square inch per 3,000 Btuh of all appliances in the room</p>
<p>* Requirements for using the single air opening option</p>	<p>A single combustion air opening can be used for cases b, c, or d above, sized as listed, provided that the following are met:</p> <ul style="list-style-type: none"> • The single opening must communicate directly to open air outside of the building or to a space that communicates directly to the outside of the building. • The top of the opening must be within 12" of the ceiling. • The free area of the opening must be at least equal to the sum of the areas of all equipment vent connectors in the space. 	
<p>IMPORTANT A special exception exists for large spaces. See the information to the right.</p>	<p>No combustion air openings are needed when the boiler and other appliances are installed in a space with a volume no less than 50 cubic feet per 1,000 Btuh of all appliances in the space. The building must NOT be of tight construction.</p> <p>Calculation: Take the total inputs of all appliances in MBH (1,000s Btuh) and multiply by 50. The space volume must be equal to or greater than the total of this calculation. [Total appliances input in MBH x 50] ≥ space volume</p> <p>Example: For a total input of 1500 MBH (1,500,000 Btuh), the minimum space volume necessary would be 1500 x 50 = 75,000 cubic feet.</p>	

Gas Venting Requirements — Category II

Using a Chimney

⚠WARNING

A chimney must be completely lined with a suitable Category II rated, water-tight lining, with a way to drain away condensate that is formed in the vent or chimney. Failure to comply could result in severe personal injury, death, or substantial property damage.

A chimney must be completely lined with a suitable Category II rated lining, in accordance with UL 1738 Venting Systems for Gas-Burning Appliances. The lining must be water-tight, with means to drain away condensate that is formed in the vent or chimney.

Only other Category II rated appliances can be common vented with the boiler in an engineered vent system (by others) designed for such an application.

- The category II rated vent material must be installed per the vent manufacturer's instructions.

- A list of approved vent suppliers and systems is provided in Table 15.
- See Table 16 for required adapters to the 88 boiler vent connector.
- The chimney must be fitted with a sealed access opening through which the interior of the chimney can be inspected.
- The chimney and liner must be inspected at least once annually.

Vent Piping Materials

Use only the materials listed in Table 15 for vent and air piping. Ensure that all materials used meet local codes.

⚠WARNING

DO NOT mix piping from different pipe manufacturers unless using adapters specifically designed for that purpose by the manufacturer. Failure to comply can result in severe personal injury, death, or substantial property damage.

Table 15 Vent piping materials

Items	Material	Supplier / Manufacturer	United States
Vent or air pipe fittings	AL29-4C or 316 stainless steel	M&G Simpson-DuraVent - Fas-N-Seal or Fas-N-Seal Flex	UL 1728 certified for Category II & IV and direct vent appliance venting
		Heat Fab, Inc. - Saf-T-Vent™ -Requires adapter by others-	
		Metal-Fab, Inc. - CORR/GUARD -Requires adapter by others-	
		Z-Flex, Inc. - Z-Vent II -Requires adapter by others-	

Table 16 Vent adapter part numbers

Approved vent material suppliers	Product Name	Supplier vent adapter required to connect to boiler					
		488-588	688-788	888-1088	1188-1388	1488-1788	1888
		10"	12"	14"	16"	18"	20"
Duravent	Fas-N-Seal	Not required	Not required	Not required	Not required	N/A	N/A
	DuraSeal	N/A	N/A	N/A	N/A	Not required	Not required
MetalFab	Corr/Guard	10FCSLCA	12FCSLCA	14FCSLCA	16FCSLCA	18CSSBAI	20FCSSBAI
HeatFab	Saf-T-Vent	91001MAD	91201MAD	91401MAD	91601MAD	SS18HFM	SS20HFM
Z-Flex	Z-Vent	2SVSAFNS10	2SVSAFNS12	2SVSAFNS14	2SVSAFNS16	2SVSADS18	2SVSADS20



Gas Venting Requirements — General

General Gas Venting Information

Model 88 boilers operate with positive overfire pressure. Adjust the damper assembly during burner start-up to achieve 0.1" W.C. positive pressure at damper sample hole. See page 47 for more information.

The vent system for a Category II or IV model 88 water boiler is considered a designed and engineered vent system. This system should be designed by a professional using accepted engineering practices in accordance with local authority having jurisdiction.

See Table 17 for technical data for an engineered vent system. WM recommends contacting your preferred vent supplier to provide design support.

Engineered Vent System

⚠WARNING

Conventional Category I flue pipe should not be used as it could leak flue gases, carbon monoxide emissions, and acidic condensate through seams and joints, which can result in severe personal injury or death.

Table 17 Technical data for sizing engineered vent system

88 Series 3 Water - Category II and IV Venting Information								
Boiler Model	Input	Stack / Vent Flow Rate*	Typical Flue Temperature*	Damper Assembly Port Pressure	Category II Venting Pressure to be maintained at Vent Connection (after Damper Assembly)	Category IV Venting Pressure to be maintained at Vent Connection (after Damper Assembly)	Boiler Flue Collar Diameter	Vent Connection / Minimum Vent Diameter
	BTU/hr	CFM	°F	Inches w.c.	Inches w.c.	Inches w.c.	inches	inches
488-W	960,000	283	255 - 275	0.1	-0.1 to 0	0 to 0.1	10	10
588-W	1,280,000	377	255 - 275	0.1	-0.1 to 0	0 to 0.1	10	10
688-W	1,600,000	471	255 - 275	0.1	-0.1 to 0	0 to 0.1	12	12
788-W	1,920,000	565	255 - 275	0.1	-0.1 to 0	0 to 0.1	12	12
888-W	2,240,000	660	255 - 275	0.1	-0.1 to 0	0 to 0.1	14	14
988-W	2,560,000	754	255 - 275	0.1	-0.1 to 0	0 to 0.1	14	14
1088-W	2,880,000	848	255 - 275	0.1	-0.1 to 0	0 to 0.1	14	14
1188-W	3,200,000	942	255 - 275	0.1	-0.1 to 0	0 to 0.1	16	16
1288-W	3,520,000	1036	255 - 275	0.1	-0.1 to 0	0 to 0.1	16	16
1388-W	3,840,000	1131	255 - 275	0.1	-0.1 to 0	0 to 0.1	16	16
1488-W	4,160,000	1225	255 - 275	0.1	-0.1 to 0	0 to 0.1	16	18
1588-W	4,480,000	1319	255 - 275	0.1	-0.1 to 0	0 to 0.1	16	18
1688-W	4,800,000	1413	255 - 275	0.1	-0.1 to 0	0 to 0.1	16	18
1788-W	5,120,000	1508	255 - 275	0.1	-0.1 to 0	0 to 0.1	16	18
1888-W	5,440,000	1602	255 - 275	0.1	-0.1 to 0	0 to 0.1	16	20

*Based on the unit operating at nominal conditions. This value can vary based on the installation location and the operating conditions.

Types of Gas Venting Systems

Category IV venting: positive pressure and likely to condense in the vent.

Boiler, breeching and vent operate at positive pressure. The entire engineered vent system must be rated for Category IV venting. Ensure 0.1" positive pressure at test opening. The minimum vent height is 3 feet above roof or snow line, and in accordance to local codes that have jurisdiction. See Figure 27.

Category II venting: negative pressure and likely to condense in the vent.

Boiler operates with positive pressure overfire. Chimney may provide excess draft, which may require the installation of a draft control device to minimize draft in accordance to local codes that have jurisdiction. The control must be set to maintain 0.1" positive pressure at the flue collar. The minimum vent height is 3 feet above roof or snow line, and in accordance to local codes that have jurisdiction. See Figure 28 and Figure 29.

Figure 27 Category IV venting, single boiler (typical shown)

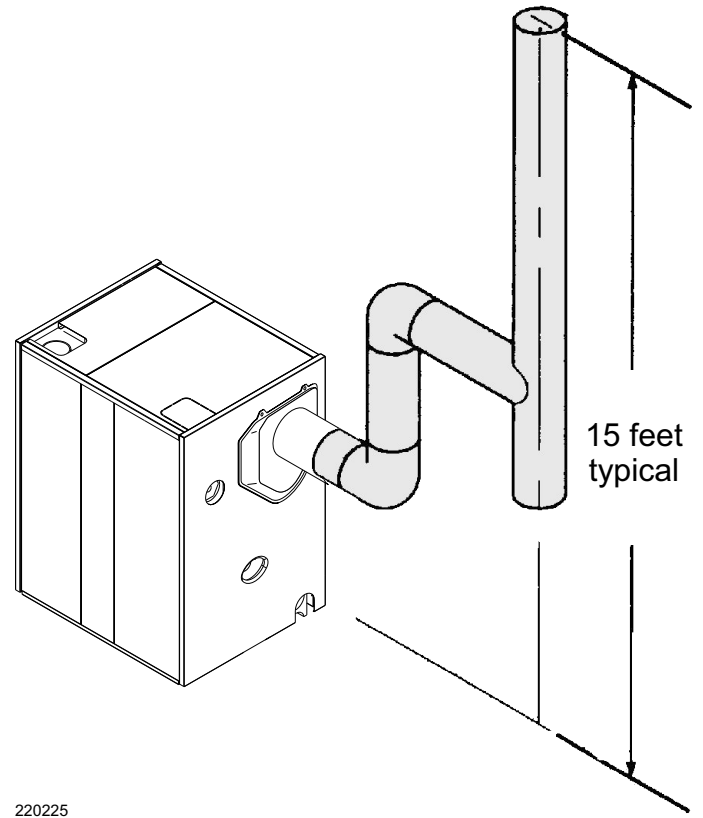

220225

Figure 28 Category II venting, single boiler (typical shown)

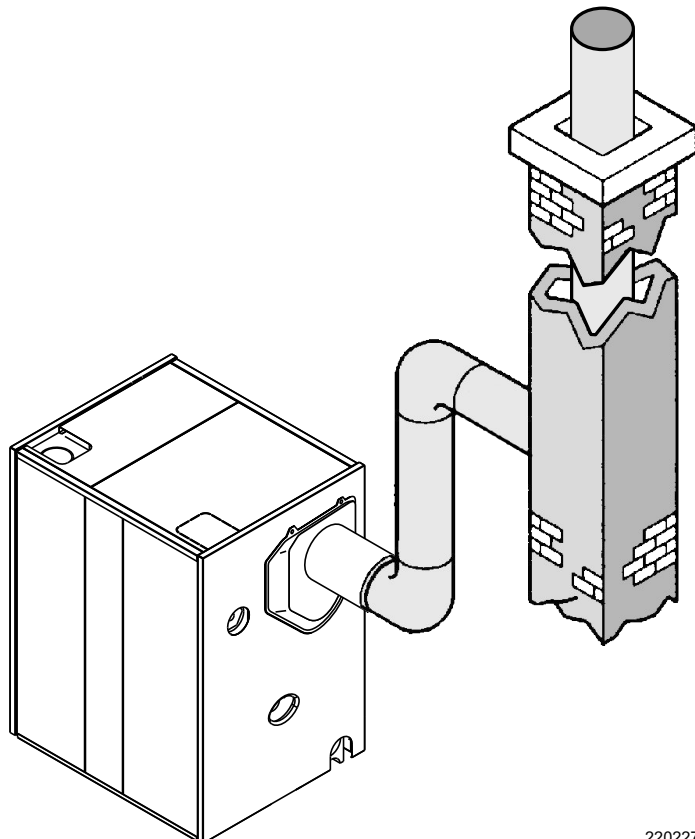

220227

Figure 29 Category II venting, multiple boilers (typical shown)

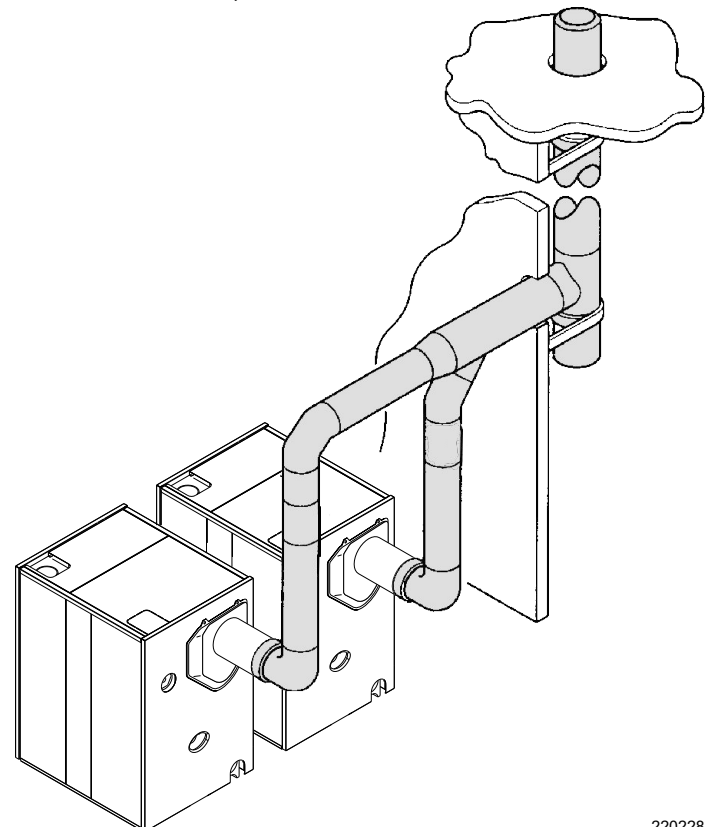

220228

Oil Venting Requirements

Using a Chimney

⚠ WARNING

A chimney must be completely lined in accordance with Installation of Oil Burning Equipment – ANSI/NFPA 31, and Chimneys, Fireplaces, Vents, and Solid Fuel Burning Appliances – ANSI/NFPA 211, latest editions, and any local codes having jurisdiction. Failure to comply could result in severe personal injury, death, or substantial property damage.

A chimney must be completely lined with a suitable lining, in accordance with Installation of Oil Burning Equipment – ANSI/NFPA 31, and Chimneys, Fireplaces, Vents, and Solid Fuel Burning Appliances – ANSI/NFPA 211, latest editions, and any local codes having jurisdiction. The lining must be water-tight, with means to drain away condensate that is formed in the vent or chimney.

Only other natural draft / negative pressure rated appliances can be common vented with the boiler in an engineered vent system (by others) designed for such an application.

- The chimney liner rated vent material must be installed per the vent manufacturer's instructions.
- The chimney must be fitted with a sealed access opening through which the interior of the chimney can be inspected.
- The chimney and liner must be inspected at least once annually.

Vent Piping Materials

Due to the increased efficiency of the 88 Series 3 water boiler, only Type L with Stainless Steel inner pipe vent material certified to UL 641 Type L Low-Temperature Venting Systems should be used. All alternate venting systems are at the discretion of the jurisdiction having authority.

⚠ WARNING

DO NOT mix piping from different pipe manufacturers unless using adapters specifically designed for that purpose by the manufacturer. Failure to comply can result in severe personal injury, death, or substantial property damage.

General Oil Venting Information

Model 88 boilers operate with positive overfire pressure. Adjust the damper assembly during burner start-up to achieve 0.1" W.C. positive pressure at damper sample hole. See [page 47](#) for more information.

Engineered Vent System

⚠ WARNING

Conventional flue pipe should not be used as it could leak flue gases, carbon monoxide emissions through seams and joints, and corrode due to acidic condensate, which can result in severe personal injury or death.

The vent system for a model 88 water boiler is considered a designed and engineered vent system. This system should be designed by a professional using accepted engineering practices in accordance with local authority having jurisdiction.

See Table 17 for technical data for an engineered vent system. WM recommends contacting your preferred vent supplier to provide design support.

Table 18 Technical data for sizing engineered vent system

88 Series 3 Water - Oil Technical Data for Designing Vent System								
Boiler Model	Input	Stack/ Vent Flow Rate*	Typical Flue Temperature*	Damper Assembly Port Pressure	Natural Draft / Negative Pressure Venting	Positive Pressure Venting	Boiler Flue Collar Diameter	Vent Connection / Minimum Vent Diameter
					Pressure to be Maintained at Vent Connection (after Damper Assembly)	Pressure to be Maintained at Vent Connection (after Damper Assembly)		
	BTU/hr	CFM	°F	Inches w.c.	Inches W.C.	Inches W.C.	Inches	Inches
488-W	960,000	243	300	0.1	-0.1 to 0	0 to 0.1	10	10
588-W	1,280,000	324	300	0.1	-0.1 to 0	0 to 0.1	10	10
688-W	1,600,000	405	300	0.1	-0.1 to 0	0 to 0.1	12	12
788-W	1,920,000	486	300	0.1	-0.1 to 0	0 to 0.1	12	12
888-W	2,240,000	567	300	0.1	-0.1 to 0	0 to 0.1	14	14
988-W	2,560,000	648	300	0.1	-0.1 to 0	0 to 0.1	14	14
1088-W	2,880,000	729	300	0.1	-0.1 to 0	0 to 0.1	14	14
1188-W	3,200,000	811	300	0.1	-0.1 to 0	0 to 0.1	16	16
1288-W	3,520,000	892	300	0.1	-0.1 to 0	0 to 0.1	16	16
1388-W	3,840,000	973	300	0.1	-0.1 to 0	0 to 0.1	16	16
1488-W	4,160,000	1054	300	0.1	-0.1 to 0	0 to 0.1	16	18
1588-W	4,480,000	1135	300	0.1	-0.1 to 0	0 to 0.1	16	18
1688-W	4,800,000	1216	300	0.1	-0.1 to 0	0 to 0.1	16	18
1788-W	5,120,000	1297	300	0.1	-0.1 to 0	0 to 0.1	16	18
1888-W	5,440,000	1378	300	0.1	-0.1 to 0	0 to 0.1	16	20

*Based on the unit operating at nominal conditions. This value can vary based on the installation location and the operating conditions.

Oil Venting Requirements, continued

Types of Oil Venting Systems

Positive pressure venting:

Boiler, breeching and vent operate at positive pressure. The entire engineered vent system must be rated for positive pressure venting. Ensure 0.1" positive pressure at test opening. The minimum vent height is 3 feet above roof or snow line, and in accordance to local codes that have jurisdiction. See Figure 27.

Natural draft or negative pressure venting:

Boiler operates with positive pressure overfire. Chimney may provide excess draft, which may require the installation of a draft control device to minimize draft in accordance to local codes that have jurisdiction. The control must be set to maintain 0.1" positive pressure at the flue collar. The minimum vent height is 3 feet above roof or snow line, and in accordance to local codes that have jurisdiction. See Figure 28 and Figure 29.

Figure 30 Positive pressure venting, single boiler (typical shown)

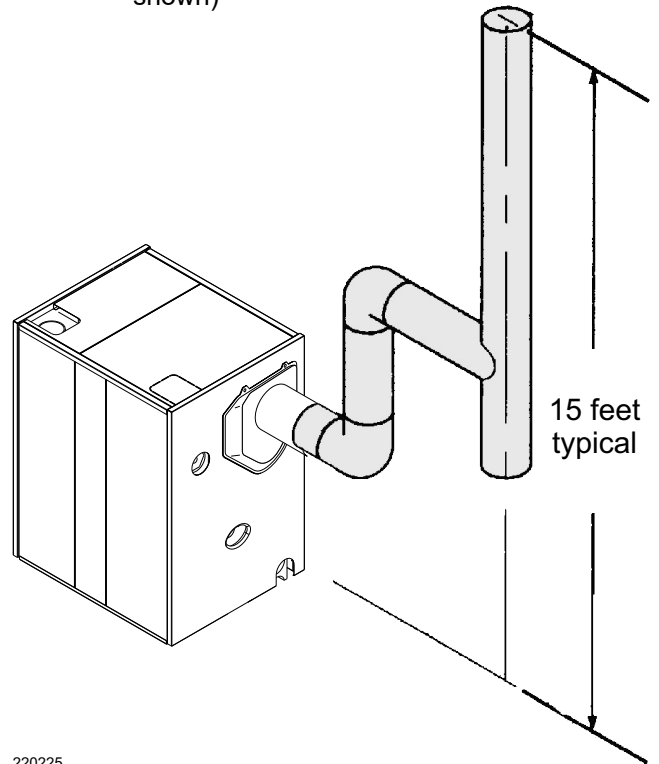

220225

Figure 31 Negative draft / negative pressure venting, single boiler (typical shown)

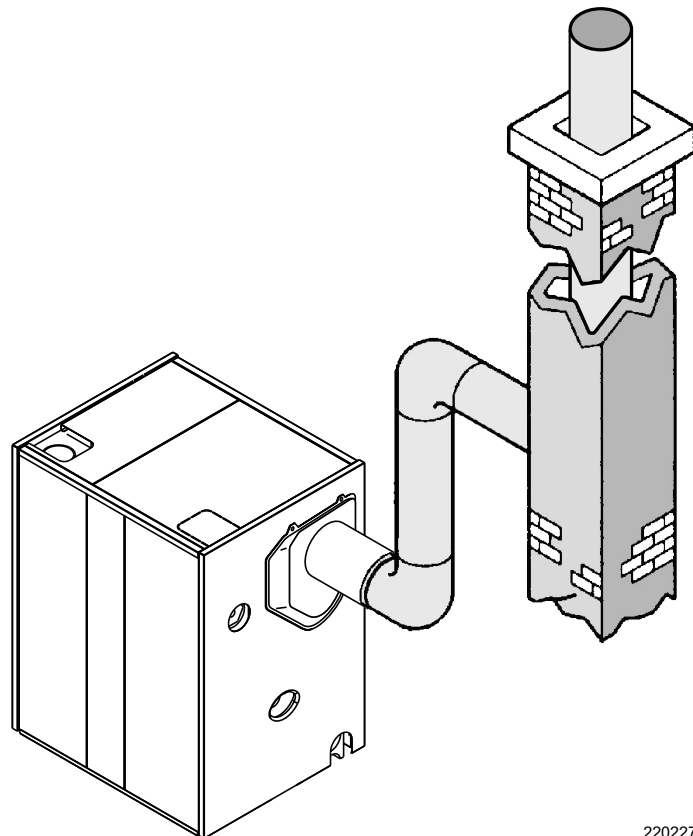

220227

Figure 32 Negative draft / negative pressure venting, multiple boilers (typical shown)

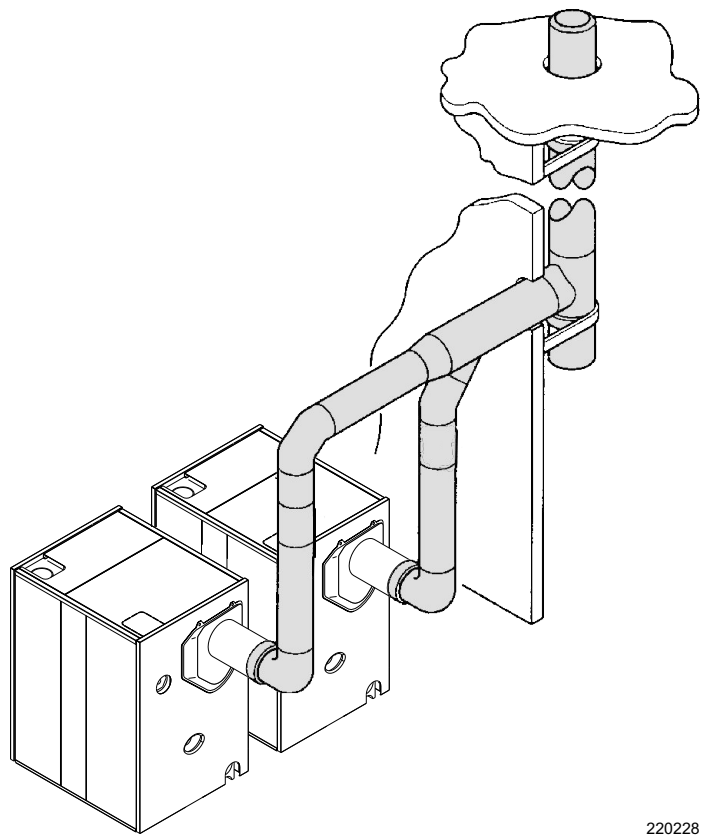

220228

Install Burner and Fill the System

Burner Installation

1. Unpack the burner.
2. Place the gasket around the air tube and against the burner mounting flange. If sealing rope is used, apply 1/8" continuous bead of rope adhesive around the burner mounting flange. Apply sealing rope over the adhesive to make a gas-tight seal.
3. Mount the burner into the opening in the burner mounting plate.

NOTICE

Maintain a gas-tight seal between the burner mounting flange and plate to prevent damage to the air tube.

IMPORTANT

If a boiler base is not utilized, the application burner specification and boiler manual dimensions should be reviewed for burner height to burner opening in the boiler. Some burner manufacturers may offer an optional inversion kit to invert the burner, allowing clearance to the floor.

4. Level the burner using burner support brackets where required; secure with furnished bolts.
5. Retain the burner information packet and keep with the boiler.

Wire the Burner and Boiler Controls

WARNING

Electric shock hazard! Disconnect the power source before installing or servicing the boiler or burner. Failure to comply can cause severe personal injury or death.

1. Install all wiring in compliance with the National Electrical Code – ANSI/NFPA 70, latest edition, and any additional national, state, or local codes.
2. Follow the burner manual and wiring diagram found in burner information packet.

Figure 33 Limit chain diagram

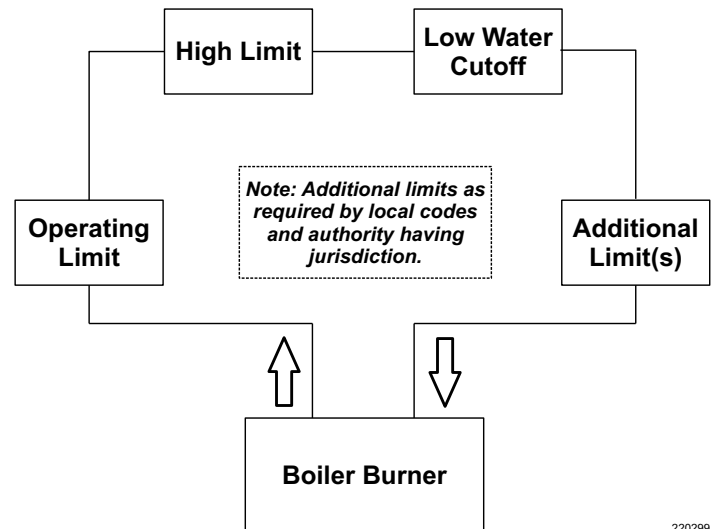

220299

3. Use #14 AWG wire for operating and safety circuit wiring.
4. Where burner motor voltage differs from control voltage, supply proper voltage to each. Size fused disconnects and conductors per the National Electrical Code – ANSI/NFPA 70, latest edition.
5. Ensure all manual and automatic reset controls are part of the same chain and are connected to the burner as directed by the burner manufacturer's instructions. Refer to [Figure 6, page 15](#) for proper controls location and [Figure 33](#) for same chain layout.
6. Check operation of the LWCO according to the instructions provided by the LWCO manufacturer.
7. Check operation of all limits according to the instructions provided by the limit manufacturer.

Install Burner and Fill the System, continued

Water Treatment

Determine if water treatment is needed in the boiler system. Continual make-up water will reduce boiler life. Minerals can build up in sections, reducing heat transfer, overheating cast iron and resulting in section failure.

For unusually hard water areas or low pH conditions (less than 7.0) consult local water treatment company. Provide a water softener for make-up water if hardness exceeds 7 grains.

NOTICE

Do not use petroleum-based cleaning or sealing compounds in boiler system. Using these compounds can cause severe damage to system components, resulting in substantial property damage.

Freeze Protection (when used)

1. Use antifreeze specifically made for hydronic systems; inhibited propylene glycol is recommended.

⚠WARNING

Do not use automotive, ethylene glycol or undiluted antifreeze. Failure to comply can result in severe personal injury, death, or substantial property damage.

2. 50% solution provides protection to about -30°F.
3. Local codes may require back-flow preventer or actual disconnect from city water supply.
4. Determine the quantity of antifreeze according to system water content. Boiler water content is listed in [Table 21, page 57](#). The solution percentage will affect sizing of heat distribution units, circulator, and expansion tank.
5. Follow antifreeze manufacturer's instructions.

Fill the Water Boiler System

1. Close the manual air vents and drain cocks.
2. Fill the system to the correct pressure. The correct pressure will vary with each installation.
3. Starting on the lowest floor, open air vents one at a time. Close the vent when water flows out. Repeat with the remaining vents.
4. Refill the boiler to the correct pressure.

Fuel Piping

Gas Piping

1. Consider these factors when sizing the gas piping:
 - Diameter and length of the gas supply piping.
 - Number of fittings.
 - Maximum gas consumption (including any possible future expansion).
 - Allowable loss in gas pressure from the gas meter outlet to the boiler.
 - Apply recognized engineering practices to size the piping.
2. See the burner manual and material list for the minimum inlet natural gas pressure required at the manual main shut-off valve.
3. Pipe dope must be resistant to corrosion by liquefied petroleum gases. Apply pipe dope sparingly and only to the male threads of pipe joints.
4. A ground joint union must be installed in the piping to provide for servicing. The supply piping must include a manual shut-off valve and sediment trap. See Figure 34.
5. Piping must be supported by hangers, not by the burner or its accessories.
6. Purge all air from the supply piping.
7. All gas piping must be tested for leaks after installation; use soap suds mixture only.

Figure 34 Gas supply piping

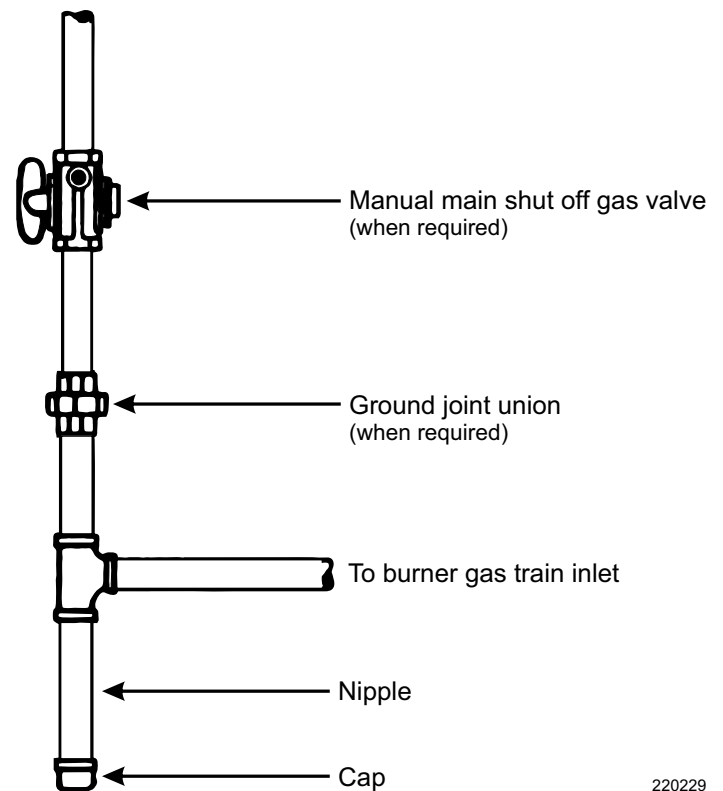

220229

Fuel Piping, continued

Fuel Oil Piping

⚠ DANGER

Fire Hazard – DO NOT use soldered fittings when installing fuel oil piping: No safe repair can be made.

⚠ WARNING

Oil flow must be prevented in case of oil line breakage. Failure to comply can cause fuel leakage or fire, which can result in severe personal injury, death, or substantial property damage.

⚠ CAUTION

Do not install the oil filter outside or close to an outside wall.

1. Prevent oil flow in case of oil line breakage.
 - a. Use an anti-siphon device when any part of the oil tank is above burner level.
 - b. Use a check valve in the suction line on the burner side of the manual shut-off valve nearest the tank when the top of the fuel oil tank is below burner level.
2. A two-pipe fuel oil piping system is required for all installations.
3. Supply and return lines must enter the tank from the top, extending to within 4"-6" from the bottom of the tank.
4. Install the oil filter. Use an oil filter sized for the fuel pump suction gear capacity.
5. Use continuous copper tubing to reduce possible piping leaks and ensure a reliable seal when oil piping is buried.
6. Use flare fittings, not compression fittings.
7. Pipe dope must be resistant to corrosion of fuel oil. Apply pipe dope sparingly and only to the male threads of pipe joints.
8. Supply and return piping should be sized to design conditions, but not less than .50" outer diameter continuous copper tubing.
9. An auxiliary fuel oil pump is recommended when suction line lift exceeds 12 feet.
10. Install swing joints so they will tighten as the buried tank settles to prevent fuel line breakage.
11. Where iron pipe is required by local codes, make swing joints with nipples and elbows several inches long on both suction and return lines; locate close to the tank.
12. Install a manual shut-off valve in the suction line piping near the burner and where piping enters the building from the outside tank.
13. Pitch the suction line piping toward the fuel tank.
14. Provide a tee and plug at the highest point in the suction line to release air and aid in priming.

Final Adjustments

Adjust the Burner and Damper Assembly

NOTICE

Make final burner adjustments using combustion test equipment to assure proper operation. Do not fire boiler without water. Sections will overheat, damaging the boiler and resulting in substantial property damage.

1. Lock flue damper OPEN. See Figure 35.
2. Refer to burner manual for start-up and service.
3. Let burner advance to high fire. Heat boiler to design conditions.
4. Using combustion test equipment, adjust burner:
 - a. 12% (\pm .50%) CO₂ for No. 2 fuel oil, 0 smoke.
 - b. 9%-10% CO₂ natural gas; CO in flue gas not to exceed 50 ppm (0.01%).

IMPORTANT

On some applications, if draft conditions or burner characteristics cause the burner flame pattern to impinge on the combustion chamber wall, pinging sounds may come from the boiler. Adjust the burner if possible to redirect the flame. If this does not work, contact your boiler supplier or WM Technologies to obtain an optional combustion chamber kit. See the parts section starting on [page 51](#) for ordering information.

5. Adjust the flue collar damper (Figure 35) to ensure 0.1" W.C. positive pressure at test opening. Take the 0.1" W.C. positive pressure reading while boiler is running at high fire rate.
6. Tighten screws to secure into position.
7. Plug test opening with the 1/8" plug provided with flue collar damper assembly.
8. Adjust barometric draft control (when used) to design conditions.
9. Repeat steps 4-6. Make adjustments as required.

Figure 35 Flue collar damper assembly

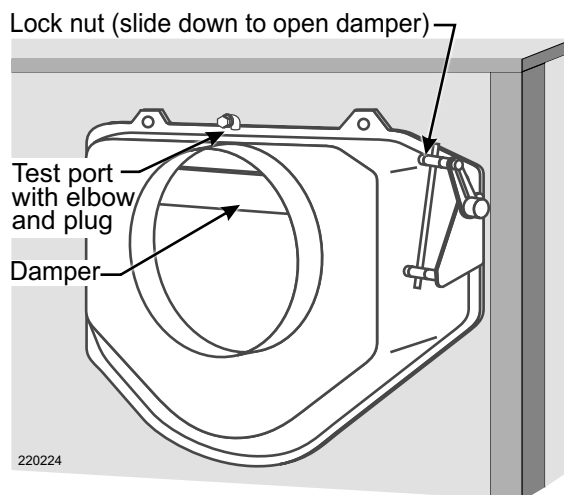

Check the Boiler for Gas-Tight Seal

⚠ WARNING

Boiler must be sealed gas-tight to prevent possible flue gas leakage and carbon monoxide emissions. Failure to comply can result in severe personal injury or death.

⚠ WARNING

The boiler contains ceramic fiber and fiberglass materials. Use care when handling these materials per instructions on [page 49](#) of this manual. Failure to comply could result in severe personal injury.

1. Remove boiler jacket side and top panels.
2. Start the burner. Observe all sealing points and chalk mark any points that are not gas-tight.
3. To seal all areas marked with chalk:
 - a. Use silicone sealant on section flueways.
 - b. Check gaskets and sealing rope placement.
4. Reinstall all jacket panels.

This page intentionally left blank



SECTION 3

Maintenance

This section is intended to provide maintenance instructions and timing for the boiler.

Section Contents

Maintenance - General	49
Annual Inspection	50

Maintenance - General

⚠WARNING

Turn off power to the boiler before any service operation except as noted otherwise in this manual. Failure to turn off electrical power can cause electrical shock, which can result in severe personal injury or death.

Handling Ceramic Fiber Materials

⚠WARNING

The burner front plate and clean out plate gaskets contain ceramic fiber materials that have been identified as carcinogenic, or possibly carcinogenic, to humans. Follow all preventative measures in this section when handling these parts. Failure to comply could result in severe personal injury or death.

⚠WARNING

This product contains fiberglass jacket insulation and ceramic fiber materials in jacket insulation, burner front plate insulation and clean out plate gaskets. Airborne fibers from these materials have been listed by the State of California as a possible cause of cancer through inhalation. Follow all preventative measures as stated in this section when handling these parts. Failure to comply can result in severe personal injury or death.

Ceramic fibers can be converted to cristobalite in very high temperature applications. The international Agency for Research on Cancer (IARC) has concluded, "Crystalline silica inhaled in the form of

quartz or cristobalite from occupational sources is carcinogenic to humans (Group 1)."

Use of an N95 respirator is based on the OSHA requirements for cristobalite at the time this document was written. Other types of respirators may be needed depending on the job site conditions.

Preventative measures include the following:

- Avoid breathing in dust.
- Wear long-sleeved, loose fitting clothing, gloves, and eye protection.
- Use an N95 respirator.
- Apply enough water to the combustion chamber lining or base insulation to prevent airborne dust.
- If replacement is necessary, remove combustion chamber lining or base insulation from the boiler and place into a plastic bag for disposal.
- Operations such as sawing, blowing, tear out, and spraying may generate airborne fiber concentration requiring additional protection.
- Wash potentially contaminated clothes separately from other clothing. Rinse the clothes washer thoroughly afterwards.

Current NIOSH recommendations can be found on the NIOSH website at www.cdc.gov/niosh/homepage.html. NIOSH approved respirators, manufacturers, and phone numbers are also listed on this website.

NIOSH stated First Aid for contact or irritation:

- Eyes: Irrigate immediately
- Breathing: Fresh air

Perform Startup and Checkout

After any service procedure, verify operation of the boiler. Removing and installing components can change boiler behavior. Follow the complete procedure for boiler and system startup in this manual.



Annual Inspection

General Inspection Information

The boiler should be inspected and started at the beginning of the heating season annually, only by a qualified service technician.

NOTICE

Failure to service and maintain the boiler and system could result in equipment failure.

⚠️WARNING

Do not use solvents to clean any of the boiler components. The components could be damaged, causing unreliable or unsafe operation, which can result in severe personal injury, death, or substantial property damage.

⚠️WARNING

Turn off power to the boiler before any service operation except as noted otherwise in this manual. Failure to turn off electrical power can cause electrical shock, which can result in severe personal injury or death.

Inspect the Boiler Area

1. Verify the boiler area is free of any combustible materials, gasoline, and other flammable vapors and liquids.
2. Verify the air intake area is free of any contaminants listed on [page 33](#). Remove any contaminants that are present in the boiler intake air vicinity.
3. Verify that the damper connector drain, condensate drain system, condensate trap and piping are free of leaks and free of blockages so the condensate is allowed to flow freely to the appropriate drain.
 - a. The condensate trap must have liquid in it to provide a trap.
 - b. If the vent system is a Category IV or positive pressure, provide means to prevent flue gas leakage.

Inspect All Piping for Leaks

⚠️WARNING

Eliminate all system or boiler leaks. Piping leaks can result in severe personal injury, death, or substantial property damage.

Inspect all water and gas piping. Look for signs of leaking lines. Correct any issues found. See pages [45](#) and [47](#) for checking gas lines.

Inspect the Boiler Interior

1. Remove all side jacket panels. Inspect the interior of the boiler
2. Visually inspect each casting for signs of combustion gas leaks.
3. Visually inspect each casting and the boiler room floor for signs of water leaks.
 - a. If any signs of combustion gas or water leakage is present, repair the leak.
 - b. To repair a leak, separate the heat exchanger at the leaking connection. Use the instructions in "Assembling the Block" on [page 12](#) to repair any leaks. Refer to the Parts section starting on [page 51](#) for replacement kit information.

Check Air Openings

1. Verify that combustion and ventilation air openings to the boiler room and building are open and unobstructed.
2. Check operation and wiring of automatic combustion air dampers, if used.
3. Verify the boiler vent discharge and air intake are clean and free of obstructions.

SECTION 4

Parts

This section includes replacement parts and dimension information.

Section Contents

Ordering	51
Replacement Parts	52
Dimensions	54

Ordering

Replacement parts must be purchased through a WM Technologies distributor. Specify the boiler model and size when ordering. Include the description and part number of the replacement part. Part numbers are found on www.weil-mclain.com and the following pages.

⚠ CAUTION

Results from using modified, other manufactured parts, and parts not purchased through an authorized distributor will not be covered by warranty. These parts may damage the boiler or impair operation.

Replacement Parts

Table 19 Parts and numbers for Figure 36, page 53

Item	Description	Part Number
1	Front sections (8823)	316-301-210
2	Regular intermediate section (8825)	316-301-212
3	Tankless intermediate section (8826)	316-301-214
4	Back section (8828)	316-301-211
5	Burner mounting plate	Order for specific burner
6	Sealing rope, 1/2" — 17 foot length piece (7 feet per burner plate)	386-410-300
7	Tankless heater, number 820 (when used)	590-291-909
8	Heater gasket	590-317-579
9	Heater cover plate	450-030-934
10	Draw rod 5/8"-11UNC-2A x 13" (apply to front and rear sections)	560-134-505
11	Draft hood collar assembly (includes damper collar, damper quadrant, damper, locking plate, swivel, brackets, and rope)	
	10-inch — 488 through 588	340-004-606
	12-inch — 688 and 788	340-004-607
	14-inch — 888 through 1088	340-004-608
	16-inch — 1188 through 1888	340-004-609
	Quadrant for flue collar	330-056-634
Damper blade	460-003-646	
Damper locking plate	563-530-784	
12	Sealing rope, 1/2" — 17 foot length piece (6 feet for flue collar)	386-410-300
13	Clean out plate	450-030-965
14	Woven fiberglass gasket for clean out plate	590-317-305
15	Observation port assembly (includes frame, rope, gasket, plugs and sight glass) (2 per boiler)	
	Assembly	385-600-099
	Sight glass only	591-419-199
	Washer gasket for sight glass (2-1/8 x 1-1/4 x 1/8 inches)	590-317-580
16	Sealing rope, 3/8" (1 foot per observation port)	590-317-150
17	Burner mounting plate studs (1/2 x 3-1/2 inches)	Obtain locally
18	Clean out plate nut, 1/4"	Obtain locally
19	Cap screw, 1/2–13 x 3/4"	Obtain locally
20	Observation port screw, 10–32 x 1-1/2"	Obtain locally
21	Flue collar cap screw, 1/2" x 1-1/2"	Obtain locally
22	Flue collar washer, 11/16"	Obtain locally
23	Burner mounting plate washer, 1/2"	Obtain locally
24	Burner mounting plate nut, 1/2"	Obtain locally
25	Draw rod nut, 5/8"	Obtain locally
26	Clean out plate washer, 1/4"	Obtain locally
27	Clean out plate carriage bolt, 1/4" x 1-3/4"	Obtain locally
28	HX-baffles (see <u>page 16</u> for installation and placement details for baffles)	
	3-flueway kit (includes 3 sets of baffles)	386-410-241
	2-flueway kit (includes 2 sets of baffles)	386-410-240
—	Supply intermediate section (8824) (not shown)	316-301-213
—	Section replacement kit (includes silicone coated rope seals, rope adhesive and sealant for one joint) (not shown)	386-410-301
—	Vent Adapters and Vent Adapter Gaskets	
	10" x 10" — FasNSeal	560-907-851
	Gskt Adptr 10.25"	590-300-091
	12" x 12" — FasNSeal	560-907-852
	Gskt Adptr 12.25"	590-300-092
	14" x 14" — FasNSeal	560-907-853
	Gskt Adptr 14.25"	590-300-093
	16" x 16" — FasNSeal	560-907-841
	Gskt Adptr 16.25"	590-300-087
16" x 18" — DS	560-907-854	
16" x 20" — DS	560-907-855	

Figure 36 Replacement boiler parts

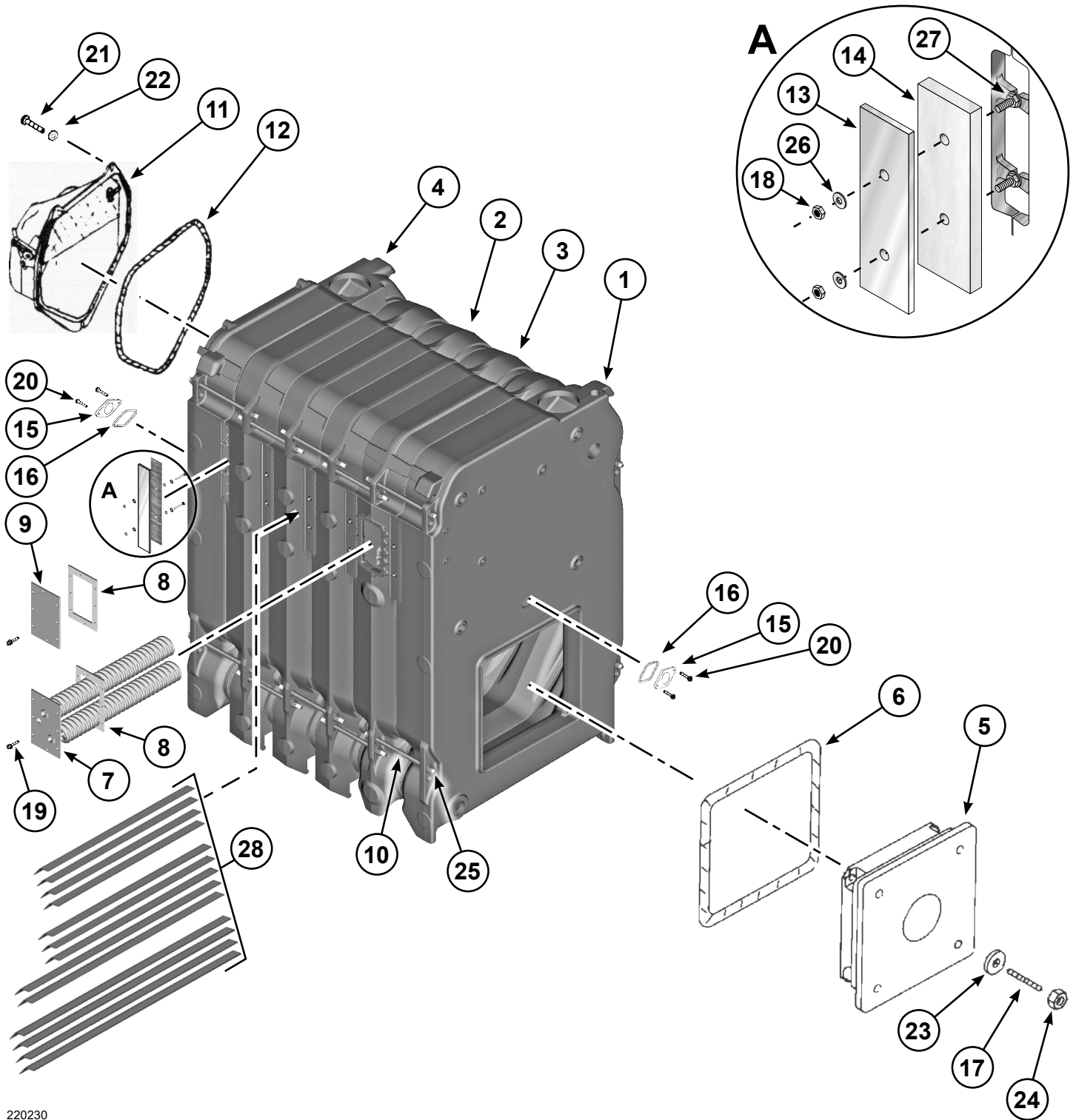

220230

Dimensions

Table 20 Dimension information for [Figure 37, page 55](#)

Dimensions (inches)						
Model	A	B	C	D	E	F
488	10	54 3/4	34 3/4	30	23 3/8	11 1/2
588	10	54 3/4	42 3/4	38	31 3/8	11 1/2
688	12	53 3/4	50 3/4	46	39 3/8	11 1/2
788	12	53 3/4	58 3/4	54	47 3/8	11 1/2
888	14	52 3/4	66 3/4	62	55 3/8	11 1/2
988	14	52 3/4	74 3/4	70	63 3/8	11 1/2
1088	14	52 3/4	82 3/4	78	71 3/8	11 1/2
1188	16	51 3/4	90 3/4	86	79 3/8	11 1/2
1288	16	51 3/4	98 3/4	94	87 3/8	11 1/2
1388	16	51 3/4	106 3/4	102	95 3/8	11 1/2
1488	18	51 3/4	114 3/4	110	103 3/8	17 11/16
1588	18	51 3/4	122 3/4	118	111 3/8	17 11/16
1688	18	51 3/4	130 3/4	126	119 3/8	17 11/16
1788	18	51 3/4	138 3/4	134	127 3/8	17 11/16
1888	20	51 3/4	146 3/4	142	135 3/8	17 11/16

Model	Supply tappings (No. and size)	Return tappings (No. and size)	Approximate Burner lengths (Dimension G) (refer to burner manuals for actual lengths)			
	Water boilers	Water boilers	Riello	Power Flame	Beckett	Webster
488	1 – 5"	1 – 6"	49	31	—	37
588	1 – 5"	1 – 6"	49	35	33	37
688	1 – 5"	1 – 6"	49	35	33	40
788	1 – 5"	1 – 6"	49	35	33	40
888	1 – 5"	1 – 6"	49	35	33	40
988	1 – 5"	1 – 6"	49	35	33	40
1088	1 – 5"	1 – 6"	64	39	33	40
1188	1 – 5"	1 – 6"	64	39	—	40
1288	1 – 5"	1 – 6"	64	39	—	40
1388	1 – 5"	1 – 6"	64	39	—	40
1488	1 – 5"	1 – 6"	64	44	—	40
1588	1 – 5"	1 – 6"	64	44	—	40
1688	1 – 5"	1 – 6"	64	44	—	48
1788	1 – 5"	1 – 6"	64	44	—	48
1888	1 – 5"	1 – 6"	64	44	—	48

Figure 37 Dimensions

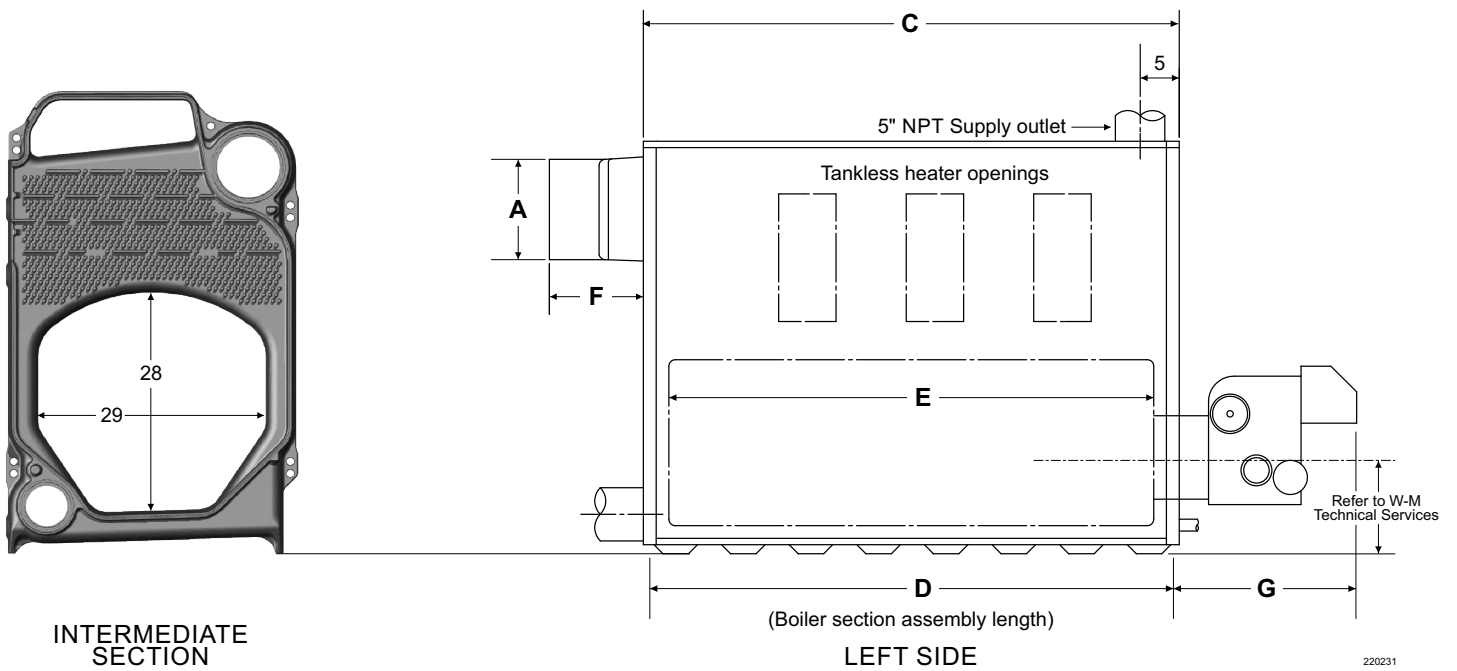
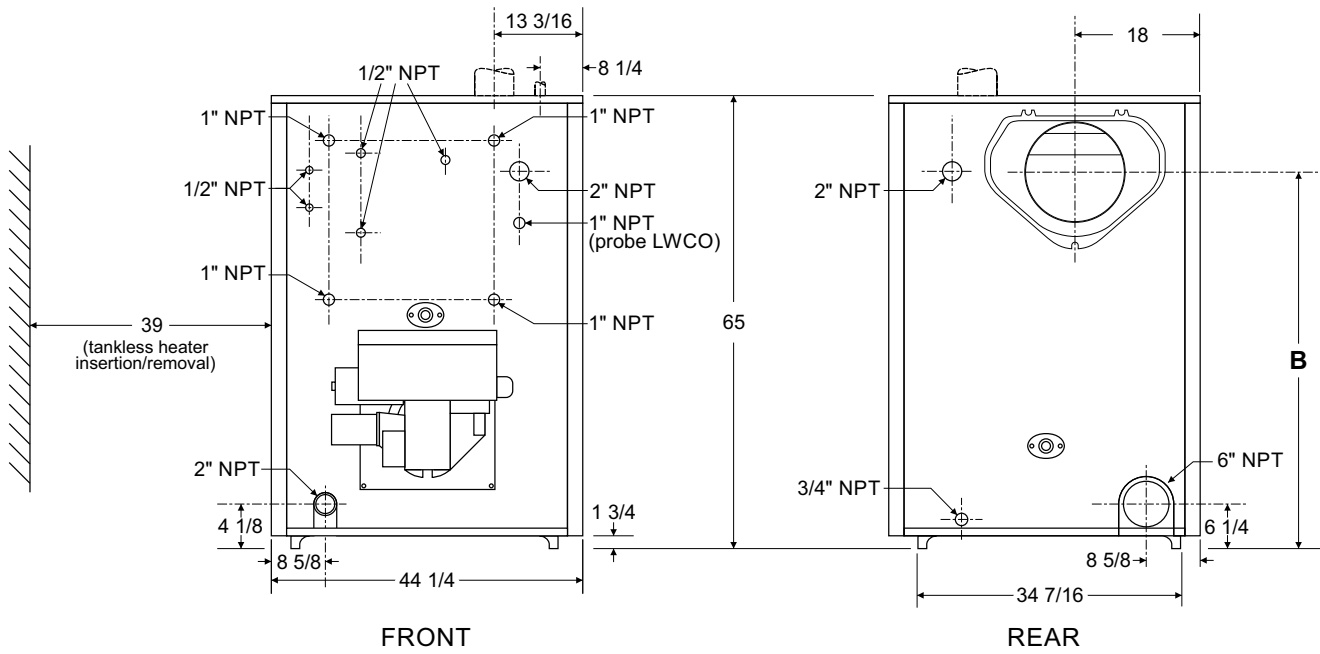

4

This page intentionally left blank

4



SECTION 5

Service Information

Section Contents

Ratings	57	Installation and Service Certificate	59
Maintenance Log	58	Notes	59

Ratings

Table 21 Ratings and engineering data



Model	AHRI Burner Capacity		Gross AHRI Output		Net AHRI Ratings		AHRI Certified Ratings				Boiler H.P.	Net Firebox Volume	Flue Outlet Dia.	Boiler Water Content	Shipping Boiler Weight
	Input Oil GPH	Input Gas MBH	Oil MBH	Gas MBH	Oil MBH	Gas MBH	Oil		Gas						
							Comb. %	Therm. %	Comb. %	Therm. %	HP	Cubic Feet	Inches	Gallons	Lbs.
488	6.9	960	840	806	731	701	—	87.0%	—	84.0%	23.8	11.02	10	109	2,860
588	9.1	1280	1108	1075	964	935	—	87.0%	—	84.0%	31.7	14.45	10	132	3,340
688	11.4	1600	1389	1344	1207	1169	—	87.0%	—	84.0%	39.7	18.08	12	155	3,820
788	13.8	1920	1681	1613	1462	1402	—	87.0%	—	84.0%	47.6	21.61	12	178	4,345
888	16.0	2240	1949	1882	1695	1636	—	87.0%	—	84.0%	55.6	25.14	14	201	4,925
988	18.2	2560	2242	2176	1950	1892	88.0%	—	85.0%	—	63.5	28.67	14	224	5,600
1088	20.5	2880	2526	2448	2196	2129	88.0%	—	85.0%	—	71.4	32.20	14	247	6,130
1188	23.0	3200	2834	2720	2464	2365	88.0%	—	85.0%	—	79.4	35.76	16	270	6,695
1288	25.0	3520	3080	2992	2678	2602	88.0%	—	85.0%	—	87.3	39.26	16	293	7,260
1388	27.5	3840	3388	3264	2946	2838	88.0%	—	85.0%	—	95.2	42.79	16	316	7,890
1488	29.5	4160	3634	3536	3160	3075	88.0%	—	85.0%	—	103.2	46.32	18	339	8,410
1588	32.0	4480	3942	3808	3428	3311	88.0%	—	85.0%	—	111.1	49.85	18	362	9,005
1688	34.5	4800	4250	4080	3696	3548	88.0%	—	85.0%	—	119.0	53.38	18	385	9,525
1788	36.5	5120	4497	4352	3910	3784	88.0%	—	85.0%	—	127.0	56.91	18	408	9,780
1888	39.0	5440	4805	4624	4178	4021	88.0%	—	85.0%	—	134.9	60.44	20	431	10,775
Notes:	2, 3	2, 4	5, 6	5, 6	7	7	—	—	—	—	—	—	—	—	—

Notes

1. See the image below to specify complete model number.

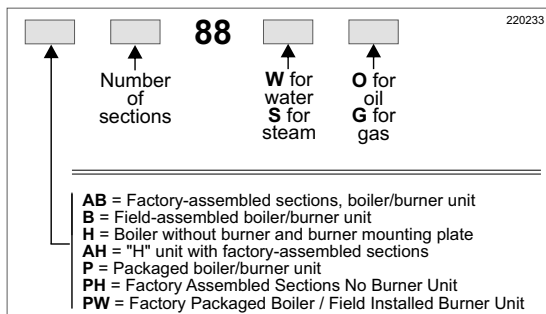

2. Burner input based on maximum of 2,000 feet altitude. For other altitudes, consult a WM Technologies distributor.
3. No. 2 fuel oil — Commercial Standard Spec CS75-56. Heating value of oil = 140,000 Btu per gallon.
4. Gas pressure required at burner gas train inlet for rated burner input; based on 1,000 Btu per cubic foot natural gas, specific gravity of 0.60. Refer to burner manual for required pressure.
5. Gross AHRI ratings have been determined under the AHRI provision governing forced draft boiler-burner units.
6. Net AHRI ratings are based on net installed radiation of sufficient quantity for the requirements of the building. Nothing need be added for normal piping and pick-up. Water ratings are based on a piping and pick-up allowance of 1.15. An additional allowance should be made for gravity hot water systems or for unusual piping and pick-up loads. Consult the local WM Technologies distributor.
7. With .10" W.C. positive pressure at flue collar.
8. Water boilers tested for 80 psig, ASME water working pressure.





WM Technologies, LLC
500 Blaine Street
Michigan City, IN 46360-2388
Telephone: (800) 654-2109
weil-mclain.com