

CAUTION

GENERAL INSTRUCTIONS

If the boiler was ordered as a complete package, thoroughly check the boiler for any concealed damage. If the boiler was ordered as factory assembled or field assembled, open all boxes and check the contents against the packing lists. In the event of shortage or damage, notify the transportation company immediately.

Boiler must be installed in accordance with our instructions so as not to void our warranty. Boiler must also be installed in accordance with Section IV of the ASME Boiler and Pressure Vessel Code and any applicable governmental and insurance codes.

AIR SUPPLY FOR COMBUSTION

An opening to the outside with a free cross sectional area of at least 20 square inches for each gallon per hour burner firing rate is recommended (CSA requires 1 sq. in. per 5000 BTUH input). For each 1,000 feet above sea level, increase the fresh air opening by 4 percent. **DO NOT INSTALL AN EXHAUST FAN IN THE BOILER ROOM.**

CHIMNEY OR VENT

(also refer to BREECHING ERECTION)

The No. 86 Boiler is designed only for forced draft, pressurized firing and may be used with a conventional chimney or stub vent. The chimney or vent must be at least the diameter indicated on the last page of these instructions under RATING-DATA-DIMENSIONS. On multiple boiler forced draft installations using one vent, consult Weil-McLain Application Engineering Department for additional venting information.

WARNING

On single or multiple boiler installations where excess (negative) draft conditions can be expected to prevail in the breeching, it may be necessary to purchase and install a full sized barometric draft regulator (same diameter as draft hood collar) for each boiler. The breeching damper which is installed in the draft hood collar at the factory must be adjusted during burner start up to assure positive pressure in the firebox and then securely locked in that position.

BOILER FOUNDATION SIZES			
BOILER NO.	L	BOILER NO.	L
486	33	1186	89
586	41	1286	97
686	49	1386	105
786	57	1486	113
886	65	1586	121
986	73	1686	129
1086	81		

BOILER FOUNDATION

A boiler foundation is recommended where the boiler room floor is not level or where the boiler room floor cannot support the weight of the boiler. Locate the boiler foundation to provide proper clearances for installation of the piping, burner, and internal water heater(s). Allow a minimum clearance of 36" from the back of the boiler for breeching erection. Allow 39" clearance to the left side for cleaning and tankless or storage heaters, if used. A level concrete pad or curb foundation is suggested of the size shown in the table and FIGURE 1. The height of the boiler foundation should be at least 2".

If the boiler is to be installed directly over electrical wiring or telephone cables in conduit buried in the concrete floor of the boiler room, a 1" thick insulated mat covered with foil should be laid on the floor underneath the boiler sections, foil face up.

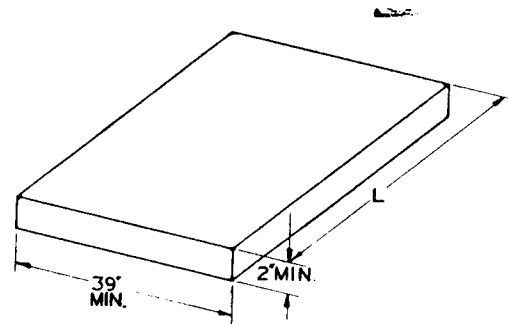

FIGURE 1

ASSEMBLED SECTIONS

If the boiler was ordered completely packaged or with the sections factory assembled, locate the unit on the boiler foundation or on the boiler room floor. After the boiler has been positioned, proceed to "HYDROSTATIC PRESSURE TEST OF BOILER".

SEALING ROPE

Listed in the SEALING ROPE USAGE TABLE are the places sealing rope must be used and the diameter and length of each piece. For expediency, the sealing rope can be pre-cut prior to starting the section assembly.

SEALING ROPE USAGE TABLE		
NOMINAL DIAMETER OF SEALING ROPE	CUT LENGTHS	ROPE USAGE AND LOCATION
1/2"	149"	Perimeter of each Section
	65"	Drafthood Collar
	76"	Burner Mounting Plate
3/8"	12"	Observation Port Frames (Front and Back)

SECTION ARRANGEMENT TABLE WITH INDIRECT WATER HEATERS

BOILER NO.	MAXIMUM NO. OF HEATERS	SECTION ASSEMBLY ALL HEATERS MUST BE ON LEFT SIDE OF BOILER
486W & S	1	RF-TI-I-BA
586W & S	2	RF-TI-I-TI-BA
686W & S	2	RF-TI-I-TI-I-BA
786W & S	3	RF-TI-I-TI-I-TI-BA
886W & S	3	RF-TI-I-TI-I-TI-I-BA
986W & S	4	RF-TI-I-TI-I-TI-I-TI-BA
1086W & S	4	RF-TI-I-TI-I-TI-I-TI-I-BA
1186W & S	5	RF-TI-I-TI-I-TI-I-TI-I-TI-BA
1286W	5	RF-TI-I-TI-I-TI-I-TI-I-TI-I-BA
1286S	4	RF-TI-I-TI-I-SI-I-TI-I-TI-I-BA
1386W	6	RF-TI-I-TI-I-TI-I-TI-I-TI-I-TI-BA
1386S	6	RF-TI-I-TI-I-TI-SI-TI-I-TI-I-TI-BA
1486W	6	RF-TI-I-TI-I-TI-I-TI-I-TI-I-TI-I-BA
1486S	5	RF-TI-I-TI-I-TI-I-SI-I-TI-I-TI-I-BA
1586W	7	RF-TI-I-TI-I-TI-I-TI-I-TI-I-TI-I-TI-BA
1586S	7	RF-TI-I-TI-I-TI-I-TI-SI-TI-I-TI-I-TI-BA
1686W	7	RF-TI-I-TI-I-TI-I-TI-I-TI-I-TI-I-TI-I-BA
1686S	7	RF-TI-I-TI-I-TI-SI-TI-I-TI-I-TI-I-TI-I-BA

RF = Front Section; BA = Back Section; I = Intermediate Section; TI = Intermediate Section with Tankless Heater Opening; SI = Steam Intermediate Section with Top Outlet Opening.

SECTION ASSEMBLY

1. Prepare the back section for erecting the boiler.
 - a. Screw a piece of 6" diameter pipe at least 36" long into the 6" return tapping in the back section.
 - b. Locate the back section on top of the boiler foundation shown in FIGURE 1. Block under the 6" diameter pipe to hold the back section upright without additional support. These sections are top-heavy and will not stand individually without support. In supporting the back section, care must be taken to assure that the section remains plumb. The 6" diameter piece of pipe can be removed after several sections have been erected.
2. Sealing rope adhesive is in a caulking tube and must be used with a caulking gun. Make a 1/8" continuous bead of adhesive in the bottom of the curved sealing grooves located around the perimeter of the section.
3. Position the 1/2" by 149" long sealing rope on the section by starting at the cleanout opening (see FIGURE 2). Be sure the sealing rope is well seated at all points in the sealing grooves so that a gas-tight seal will be maintained between the sections. DO NOT APPLY adhesive to the opposing sealing grooves of the next boiler section.
4. Wipe the port openings with a clean rag to remove any grit from the machined surfaces. Do not use any cleaner that contains a petroleum base distillate (oil) to clean ports. Place the 9" and 6" elastomer sealing rings in the appropriate port openings (see FIGURE 2).
5. Unburned oil vapors can cause failure of the elastomer sealing rings. After the elastomer sealing rings have been set in the port openings of the section, make a 1/8" diameter continuous bead of silicone sealant around the outside of the rings. Follow this procedure for each sealing ring installed (see FIGURE 3).
6. Prepare the port openings in an intermediate section. The "TI" and "SI" intermediate sections (if used) must be installed in the order given in the SECTION ARRANGEMENT WITH INDIRECT WATER HEATERS table. Additional "TI" or "SI" intermediate sections beyond those shown in the table may be used if desired. Additional knockouts in the jacket, however, are not provided and must be cut on the job by the installer. Note that 39" clearance must be provided on the left side for cleaning and heater installation.
7. Discard the 3/8" diameter rods which are required only to tie the boiler sections together during shipment. These rods must not be used to draw the sections together.
 - a. Position the intermediate section so that the aligning lugs will fit into the sockets of the adjacent section (see FIGURE 4). Oil the threads of four (4) of the longer draw rods (5/8" x 13") and slip them through the lugs on the top and sides of each section. Place a washer (only one washer per draw rod) under each nut to be tightened, with a drop of oil between washer and nut.
 - b. Starting with the draw rods nearest the port openings, draw the sections together uniformly until the metal

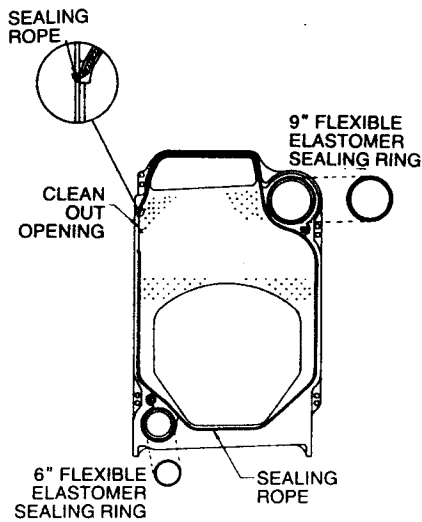

FIGURE 2

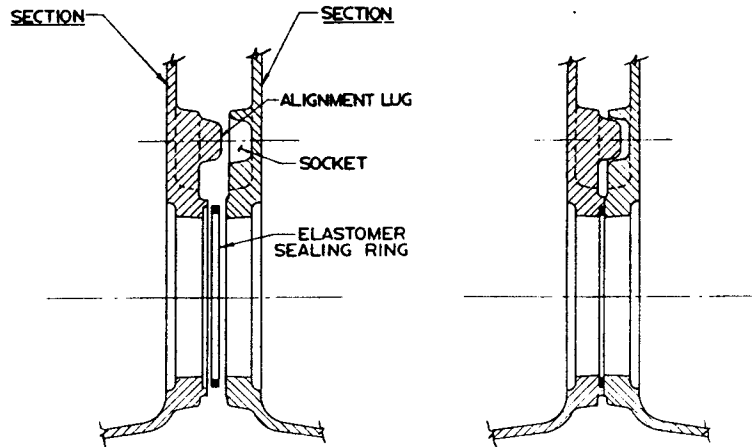

FIGURE 4

around the ports touch and the pads at the opposite corners touch. When properly pulled together the gap around the port openings should be less than 0.032". Check with a feeler gauge.

- c. Do not continue to draw sections together after metal to metal contact has occurred. Do not "back off" the draw rod nuts.
- 8. Set the remaining boiler sections into position with the "TI" and "SI" sections placed (if used) in the proper order given in the SECTION ARRANGEMENT table. Use 5/8" x 11" draw rods between any two intermediate sections. Check the sealing rope seal of each section before proceeding to the next section. The boiler must be sealed gas-tight.

WARNING

Use of chemical cleaners or sealants in any Weil-McLain boiler is not recommended. **IN PARTICULAR, PRODUCTS CONTAINING PETROLEUM DISTILLATES MUST NEVER BE USED IN TYPE 86 BOILERS!**

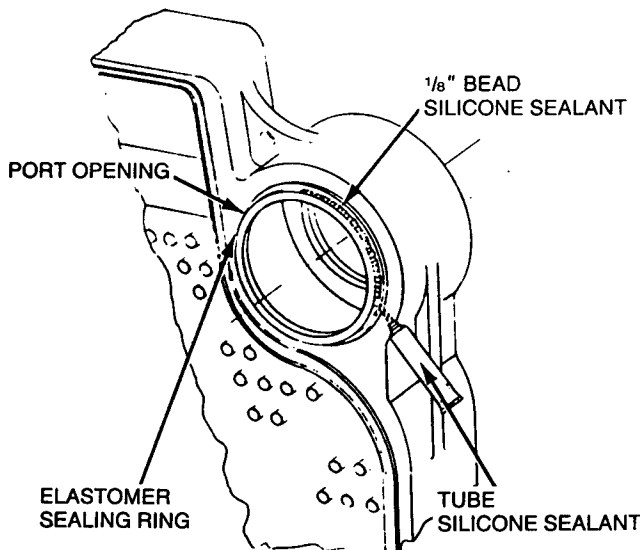

FIGURE 3

- 9. Four 1/2" x 3 1/2" studs are provided to secure the burner mounting plate to the front section (see FIGURE 5).
 - a. Thread two 1/2" nuts on the rounded end of a 1/2" x 3 1/2" stud, locking them together, and thread the flat end of the stud into one of the four tapped holes located around the burner mounting plate opening in the front section.
 - b. Remove the nuts from the stud.
 - c. Repeat steps "a" and "b" for the remaining three studs.
- 10. Make a small continuous bead of sealing rope adhesive in the groove around the burner mounting plate opening in the front section (see FIGURE 5). Position the 1/2" diameter by 76" long rope in the groove making sure the ends overlap at least 1" and install the burner mounting plate using the 1/2" washers and nuts provided. Make sure burner plate is installed properly with the part number and the word "up" positioned at the top.
- 11. Make a small continuous bead of sealing rope adhesive in the bottom of the sealing groove located around the flange of the front observation port assembly. Position the 3/8" diameter by 12" long sealing rope in the sealing groove making sure the ends overlap at least 1". Install the front observation port assembly to the front section using the number 10-3/4" truss head screws provided (see FIGURE 5).
- 12. Repeat Step 10 for the back observation port assembly.
- 13. If the boiler was ordered with "TI" or "SI" intermediate section(s), install the indirect water heater(s) and gasket(s) or heater opening cover plate(s) and gasket(s) using 3/8" x 3/4" hex head screws and washers provided (see FIGURE 5).
- 14. Place the 10 1/2" x 1 7/8" cerafelt blanket insulation pieces against the cleanout plates. Place a 1/4" x 1 3/4" carriage bolt in the cleanout opening as shown in FIGURE 5. Place a washer and nut over the bolt to hold it in place. Mount the cleanout plate over the opening and bolt the cleanout plate in position (see FIGURE 5).
- 15. Repeat step No. 14 for the remaining cleanout plates.

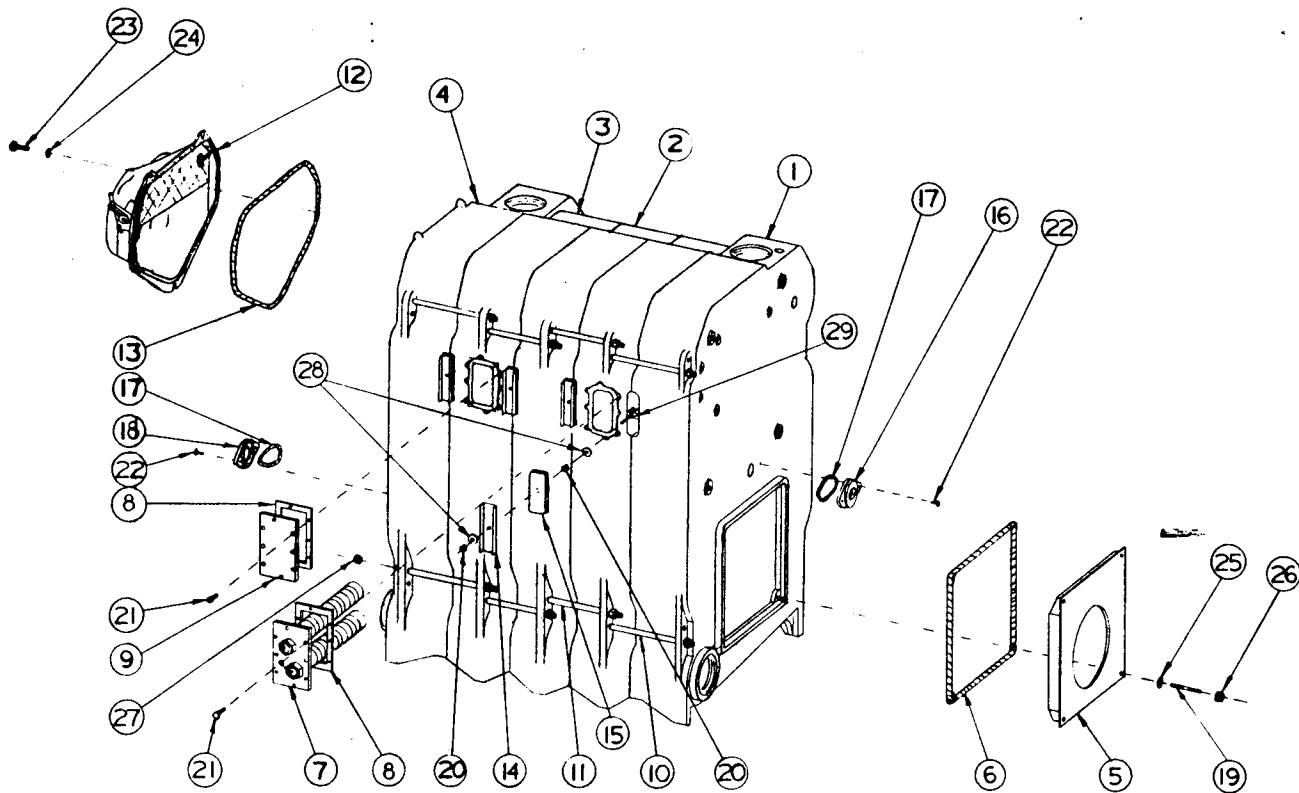

FIGURE 5

- | | | |
|--|---|--|
| 1. Front Section | 11. Draw Rod, $\frac{5}{8}$ " x 11" | 21. Cap Screw $\frac{3}{8}$ " |
| 2. Regular Intermediate Section | 12. Draft Hood Collar | 22. Observation Port Screw 10-32 x $\frac{3}{4}$ " |
| 3. Tankless Intermediate Section | 13. Sealing Rope $\frac{1}{2}$ " | 23. Draft Hood Collar Cap Screw $\frac{1}{2}$ x $1\frac{1}{2}$ " |
| 4. Back Section | 14. Cleanout Plate | 24. Draft Hood Collar Washer $1\frac{1}{16}$ " |
| 5. Burner Mounting Plate | 15. Cerafelt Blanket Insulation $10\frac{1}{2}$ " x $17\frac{5}{8}$ " | 25. Burner Plate Washer $\frac{1}{2}$ " |
| 6. Sealing Rope $\frac{1}{2}$ " | 16. Front Observation Port | 26. Burner Plate Nut $\frac{1}{2}$ " |
| 7. Tankless Heater | 17. Sealing Rope $\frac{3}{8}$ " | 27. Draw Rod Nut $\frac{5}{8}$ " |
| 8. Tankless Heater or Heater
Cover Plate Gasket | 18. Rear Observation Port | 28. Cleanout Plate Washer $\frac{1}{4}$ " |
| 9. Heater Cover Plate | 19. Burner Plate Mounting Studs | 29. Cleanout Plate Bolt $\frac{1}{4}$ " x $1\frac{3}{4}$ " |
| 10. Draw Rod $\frac{5}{8}$ " x 13" | 20. Cleanout Plate Nut $\frac{1}{4}$ " | |

16. Make a small continuous bead of sealing rope adhesive in the bottom of the sealing groove around the perimeter of the draft hood collar. Position the $\frac{1}{2}$ " diameter by 65" long sealing rope in the sealing groove of the draft hood collar making sure the ends of the rope overlap at least 1".
17. Position the draft hood collar to fit over the flueway outlet on the back section. Secure the draft hood collar to the back section using the $\frac{1}{2}$ " x $1\frac{1}{2}$ " hex head cap screws and washers provided (see FIGURE 5).

HYDROSTATIC PRESSURE TEST OF BOILER

1. If the boiler was ordered with optional $1\frac{1}{2}$ " cleanout and

inspection openings on the sections, plug these tappings using the $1\frac{1}{2}$ " brass plugs provided.

2. Secure a drain cock (not supplied) to the boiler or boiler piping (size to ASME Code requirements). Refer to FIGURE 6 and the CONTROL TAPPING TABLE.
3. Install a water pressure gauge in one of the boiler tappings so the boiler water test pressure can be measured.
4. Install a bleed valve in one of the upper boiler tappings to vent air as the boiler is filled with water.
5. Plug all remaining boiler tappings, including the returns. Refer to FIGURE 6 and the CONTROL TAPPING TABLE.

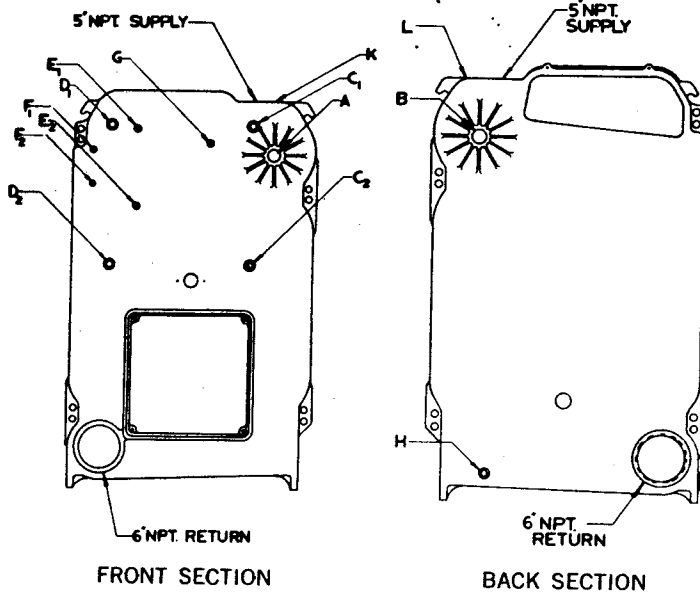

FIGURE 6

SUPPLY AND RETURN PIPING

It is recommended that the system supply and return piping be installed and the piping connections be attached to the boiler before erecting the jacket or installing the controls to avoid any possible damage to the jacket or controls. Recommended piping arrangements for No. 86 water and steam boilers are shown in FIGURES 7, 8, 9, and 10. The minimum recommended pipe sizes are listed for each piping arrangement. The supply and return piping will not interfere with the erection of the boiler jacket.

RECOMMENDED PIPING CONNECTIONS FOR WATER BOILERS

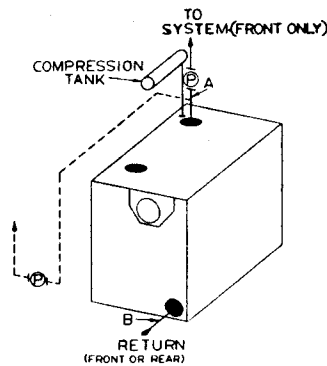

FIGURE 7

CONTROL TAPPING TABLE

LOCATION	SIZE	STEAM	WATER
A	2"	Safety Valve and/or Skim Tapping	High Limit
B	2"	Safety Valve	Pressure Relief Valve
C ₁ & C ₂	1"	Water Level Controls	—
C ₁		—	Combination High & Low Limit Control
D ₁ & D ₂	1"	Alternate Water Level Controls	Low-Water Cutoff
E ₁ & E ₂	1/2"	Gauge Glass	—
F ₁ & F ₂	3/8"	Try Cock Tappings	—
G	1/2"	Pressure Limit Control, Pressure Operating Control and Pressure Gauge	Combination Pressure-Temperature Gauge
H	3/4"	—	—
L	1"	—	Pressure Relief Valve
K	1"	—	Piping to Compression Tank or Automatic Air Vent

- Fill the boiler with water and completely vent all air. Test the boiler with water pressure not exceeding 45 pounds per square inch.

WARNING

Submit the boiler to this test for at least 10 minutes but for no longer than 30 minutes.

- Thoroughly inspect the entire boiler for water leaks. At the end of the test period, look at the water pressure gauge and ascertain that the water test pressure has remained constant.
- Drain the entire boiler and remove plugs from those tapings which will be used for controls or accessories. Refer to FIGURE 6 and the CONTROL TAPPING TABLE.

WATER BOILER PIPING RECOMMENDED MINIMUM PIPE SIZES

TABLE I FOR KNOWN FLOW RATES*

WATER FLOW RATE GPM	SUPPLY PIPE SIZE A	RETURN PIPE SIZE B
To 35 GPM	2"	2"
36 to 50 GPM	2 1/2"	2 1/2"
51 to 77 GPM	3"	3"
78 to 132 GPM	4"	4"
133 to 208 GPM	5"	5"
209 to 300 GPM	6" ‡	6"

*High temperature rise through boiler is permissible when boiler piping connections are sized using above Table 1. INTERMITTENT flow at HIGH velocities may damage any boiler.

‡ Requires nipple and 5" x 6" reducing coupling which is provided with 1286 through 1686 boilers only. The total pressure drop through the 1686 boiler using the nipple and reducing coupling will not exceed 1/4 PSI. For smaller boilers the pressure drop will be less.

TABLE II FOR UNKNOWN FLOW RATES *

BOILER NUMBER	SUPPLY PIPE SIZE A	RETURN PIPE SIZE B
486	3"	3"
586 to 786	4"	4"
886 to 1186	5"	5"
1286 to 1686	6" ‡	6"

*All piping sizes are based upon 20° F. temperature rise through the boiler. For use of other temperature rises through the boiler (i.e. higher flow rates) determine the flow rate and use Table I for pipe sizes.

‡ Requires nipple and 5" x 6" reducing coupling which is provided with 1286 through 1686 boilers only. The total pressure drop through the 1686 boiler using the nipple and reducing coupling will not exceed 1/4 PSI. For smaller boilers the pressure drop will be less.

**WATER BOILER SUGGESTED
PIPING CONNECTIONS**

FIGURE 7 and the accompanying table show recommended piping connections and minimum recommended pipe sizes for No. 86 water boilers. **Reverse water flow through the No. 86 water boiler is not recommended.** In most cases it is advisable to pump water away from the boiler supply outlet by connecting the supply piping to the inlet side of the circulator, as illustrated in FIGURE 7.

The supply and return piping and the compression tank are not supplied with the boiler but should be installed as illustrated. Controls are not shown in FIGURE 7 in order to more clearly show the water boiler piping.

In sizing the supply and return piping, start with the minimum recommended pipe size and proceed at full diameter for 10 times that diameter before making any reduction. For example, a 4" return should not be reduced any closer to the boiler return tapping than 40". Horizontal compression tank piping must pitch upward at least 1" for each 5 feet of piping from the boiler to the tank.

Where system temperature modulation is achieved by means of three-way valves, care must be exercised in piping the system to protect the boiler from thermal shock which could result from returning room temperature water at high velocities to the hot boiler. Where three-way valves are employed, consult Weil-McLain Application Engineering Department for piping recommendations. Primary-secondary pumping is preferred.

STEAM BOILER PIPING AND HEADERS

FIGURES 8, 9 and 10 and the accompanying table show recommended piping connections and minimum recommended pipe sizes for No. 86 steam boilers. The supply and return steam piping is not supplied with No. 86 steam boilers but should be installed as illustrated. Controls (safety valve, low water cut-off, gauge glass, etc.) are not shown on the steam piping diagrams in order to more clearly show the steam piping and Hartford Loop.

CAUTION

The satisfactory operation of any steam heating boiler depends upon adequate return of condensate to the boiler to maintain a steady water level. In rambling buildings with extended system piping, nuisance shutdowns sometimes result when the condensate returning from the system lags behind the evaporation capacity of the boiler. To maintain a steady water line, avoid the introduction of excessive amounts of raw make-up water. To prevent nuisance shutdowns due to a temporary low water level, it is recommended that a low water cutoff and pump control, condensate receiver, and condensate boiler feed pump be installed. Consult Weil-McLain Application Engineering Department for information.

**RECOMMENDED PIPING CONNECTIONS
FOR STEAM BOILERS**

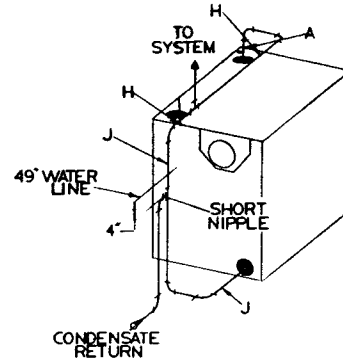

*24" minimum from waterline to header
STEAM BOILER PIPING
486 through 686

FIGURE 8

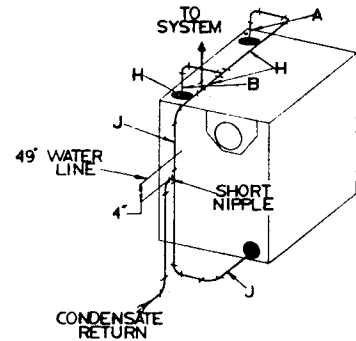

*24" minimum from waterline to header
STEAM BOILER PIPING
786 through 1186

FIGURE 9

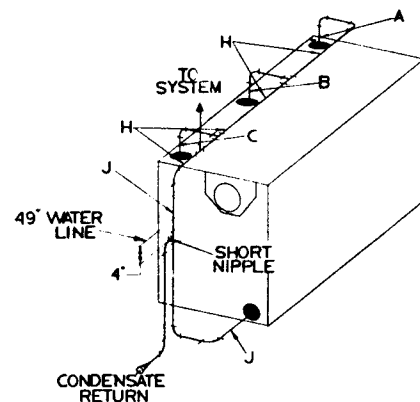

*24" minimum from waterline to header
STEAM BOILER PIPING
1286 through 1686

FIGURE 10

**STEAM BOILER PIPING
MINIMUM RECOMMENDED PIPE SIZES**

Fig. No.	Boiler Size	Riser Pipe Size			Header* H	Equalizer J
		A	B	C		
8	486	4"			4"	2½"
8	586 and 686	5"			5"	2½"
9	786	4"	4"		6"	2½"
9	886	5"	5"		6"	2½"
9	986	5"	5"		8"	2½"
9	1086	5"	5"		8"	2½"
9	1186	5"	5"		8"	4"
10	1286 thru 1486	5"	5"	5"	8"	4"
10	1586 thru 1686	5"	5"	5"	10"	4"

*24" Minimum from waterline to header.

ATTACHING THE JACKET

The boiler should be pressure tested and the supply and return piping may be attached before the jacket is erected. Make sure that only the plugs and other accessories listed to this point in these instructions are mounted on the boiler. Follow the Jacket Erecting Instructions packed in the jacket carton which contains the front and back jacket panels for jacket installation procedures.

TANKLESS HEATER HOOK-UP

Where the boiler was ordered with tankless heater(s) it is recommended that the piping to and from the heater be sized no smaller than the heater inlet and outlet piping connections. The tankless heater piping should be installed as illustrated in FIGURE 11. Where the boiler was ordered with multiple heaters, a cold water supply header with individual risers to each heater must be employed and the hot water outlets from each heater must be headered. It is recommended that a flow regulating valve be installed in the cold water supply piping to

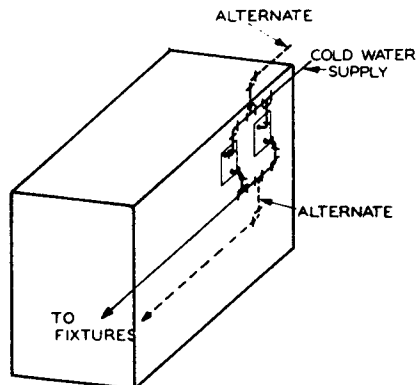

FIGURE 11

**DOMESTIC WATER HEATER CAPACITIES
TANKLESS HEATER RATINGS***

Heater Number	** Intermittent Draw GPM 100°F Average Temperature Rise	*** Continuous Draw GPM 100°F Temperature Rise	Inlet and Outlet Tappings
820	8.5 G.P.M.	8.0 G.P.M.	¾"

STORAGE HEATER RATINGS*

Heater Number	180	212	Inlet and Outlet Tappings
	Heater Capacity Gallons 40°—140°F Rise	Heater Capacity Gallons 40°—140°F Rise	
816	140 in 3 Hrs.	205 in 3 Hrs.	1"
Recommended Storage Tank	200-500 Gallons	250-500 Gallons	

*Weil-McLain Ratings
** Gallons of Water per min. heated from 40° to 140°F with 200°F boiler water temp.
*** Continuous Draw—no recovery period.

each heater. Each flow regulating valve should be sized according to the intermittent draw rating of each tankless heater. Do not pipe multiple indirect water heaters in series. An automatic mixing valve may be employed and installed in the domestic hot water supply piping from the heater(s) to regulate the domestic hot water temperature. Install the operating control in the control tapping in the heater plate. In hard water areas, it is advisable to soften the cold water to the heater(s).

STORAGE HEATER HOOK-UP

Where the boiler was ordered with storage heater(s) for best operation, the domestic water storage tank should be located as high as possible above the storage heater(s). A vertical domestic water storage tank may be used if the bottom of the storage tank is located above the boiler. To maintain optimum gravity hot water circulation, the horizontal flow piping from the storage heater(s) to the tank must pitch upward at least 1 inch for each 10 feet of piping and the horizontal return piping from the storage tank to the heater(s) must pitch downward at least 1 inch for each 10 feet of piping. Use as few pipe fittings as possible so that the least possible resistance will be encountered. The STORAGE HEATER RATING table gives the storage heater capacities and the recommended storage tank size.

INSTALL BOILER CONTROLS

Steam Boiler:

A low water cutoff, safety valve, pressure gauge, gauge glass and cocks, blow down valve, and operating and limit pressure controls must be installed on this boiler to meet ASME Code requirements.

1. Install the steam safety valve(s) in the proper tapping(s) as indicated in the CONTROL TAPPING table and FIGURE 6.

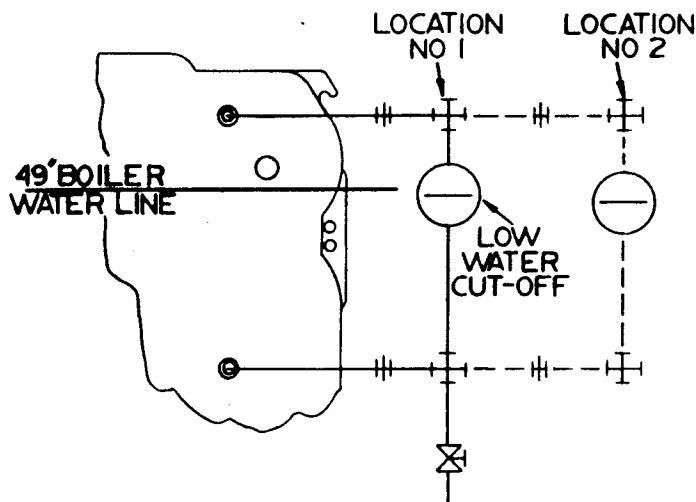

FIGURE 12

Recommended Locations For Low Water Cutoff, Water Feeders and Pump Controllers When Used on Weil-McLain Steam Boilers.*

LOCATION NO. 1		LOCATION NO. 2▶	
Primary Water Level Control ★	Casting Line Height Above Bottom of Gauge Glass	First Back-Up Water Control ★	Casting Line Height Above Bottom of Gauge Glass
150	2 ³ / ₈ "	—	—
61, 63	1/4"	—	—
93 & 94	2"	—	—
51-2 & 51-S-2	1" to 1 ¹ / ₄ "	—	—
247-2	1 ¹ / ₂ "	—	—
61 & 63	1/2"	61 & 63	1/4"
93 & 94	2"	93† & 94†	1/4"
150	2 ³ / ₈ "	150	1/4"
93 & 94	2"	61 & 63	1/4"
150	2 ³ / ₈ "	61 & 63	1/4"
93 & 94•	2"	247-2	1/4"
93 & 94•	2"	51-2 & 51-S-2	1/4"
150•	2 ³ / ₈ "	247-2	1/4"
150•	2 ³ / ₈ "	51-2 & 51-S-2	1/4"

★ Other manufacturers controls providing similar function may be used provided they are properly located and are selected to handle the boiler evaporative capacity.

† Use low water cutoff function only; pump controller function should only be used on "higher" control location.

• Use pump control function only; back-up controller to provide low water cut-off function, or low water cut-off and feeder function.

▶ If location No. 2 is not allowed by insuring agency, consult Weil-McLain technical service department for alternate location.

2. Install the low water cut-off (see FIGURE 12) in accordance with the CONTROL TAPPING TABLE and FIGURE 6. Where an optional 1" low water cut-off, combination low water cut-off and feeder, or combination low water cut-off and pump control is employed, install the control in accordance with the CONTROL TAPPING TABLE and FIGURE 6 using fittings (not furnished). If a low water cut-off is to be used that is not dimensionally diagrammed in FIGURE 12, locate the cast-on-body mark of the control 2" below the normal water line.
3. Install the gauge glass cocks, water gauge glass and gauge glass guards in accordance with the CONTROL TAPPING TABLE and FIGURE 6.
4. Install the steam pressure operating and high limit controls and the pressure gauge in the proper tapping as indicated in the CONTROL TAPPING TABLE and FIGURE 6. Use the pigtail syphon and fittings furnished (see FIGURE 13).
5. Install any additional or optional steam boiler controls according to the control manufacturer's instructions.

Two (2) pressure limit controls are furnished as standard equipment to perform low limit (operating) and high limit functions. The pressure limit control used as the operator should be set according to the design requirements of the heating system. The pressure limit control employed for high limit function should be set at least 2 PSIG higher than the operating control setting, where possible (15 PSIG maximum allowable steam boiler pressure).

For additional information on the controls, refer to the control manufacturer's instructions.

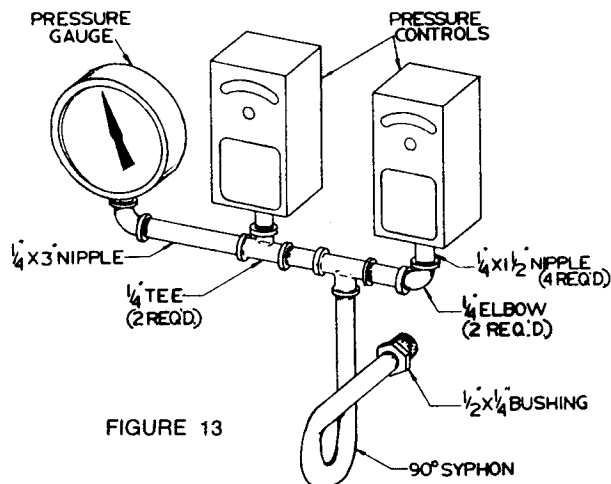

FIGURE 13

WARNING

To avoid water damage or scalding, the safety valve outlet must be piped to a floor drain or near to the floor. Do not pipe the safety valve discharge to any area where freezing temperatures could occur.

Water Boiler:

1. Install the pressure relief valve in the proper tapping as indicated in the CONTROL TAPPING TABLE and FIGURE 6.

WARNING

To avoid water damage or scalding, the relief valve outlet must be piped to a floor drain or near to the floor. Do not pipe

the relief valve discharge to any area where freezing temperatures could occur.

2. Install the combination pressure-temperature gauge as indicated in the CONTROL TAPPING TABLE and FIGURE 6.
3. Where an optional 1" low water cut-off is employed, install the control in accordance with the CONTROL TAPPING TABLE and FIGURE 6 using fittings (not furnished). Refer to FIGURE 12 for positioning. If a low water cut-off is to be used that is not dimensionally diagrammed in FIGURE 12, refer to the separate manufacturer's instructions for locating the control.
4. Install the combination limit control as indicated in the CONTROL TAPPING TABLE and FIGURE 6.
5. Install any additional limit controls in the proper tapings as indicated in the CONTROL TAPPING TABLE and FIGURE 6.
6. Install boiler drain (size per ASME Code requirements).
7. Install any additional or optional water boiler controls according to the control manufacturer's instructions.

A combination low limit (operating) control and high limit control is furnished as standard equipment. The low limit (operating) control should be set according to the design requirements of the heating system. The high limit control should always be set at least 20°F. higher than the low limit control setting, where possible (250°F. maximum allowable boiler water temperature).

For additional information on the controls, refer to the control manufacturer's instructions.

CAUTION BREECHING ERECTION

(also refer to CHIMNEY OR VENT)

Long horizontal breechings, excessive numbers of elbows or tees, or other obstructions which restrict the flow of combustion gases should be avoided. The boiler draft hood collar is furnished with the breeching damper, damper locking plate, and breeching damper handle factory installed in position. Secure the breeching to the draft hood collar using the following procedure:

1. Fit a piece of full sized heavy gauge steel breeching (same diameter as draft hood collar) over the draft hood collar. The full sized breeching must protrude at least 6 inches beyond the end of the draft hood collar so the breeching damper can be fully opened. The force fit of the breeching onto the draft hood collar must be gas-tight and should be held together with several bolts or screws.
2. Refer to the last page of these instructions under RATINGS-DATA-DIMENSIONS and determine the minimum recommended breeching diameter for the size boiler being installed. Use heavy gauge steel breeching which can be welded to connect from the chimney or vent to the piece of full sized breeching which was attached to the draft hood collar.

WARNING

The breeching must be gas-tight using welded seams and joints. Where the breeching diameter will be smaller than the

diameter of the draft hood collar, a tapered type reducing fitting which provides less resistance to the flow of combustion gases is recommended.

BURNER INSTALLATION

The oil, gas, or combination gas-oil burners supplied with the No. 86 boiler will be flange mounted to the burner mounting plate. However, some of the larger, heavier burners require a pedestal or burner support bracket. Some burners are provided with a gasket to seal between the burner flange and the burner mounting plate. Other burners are provided with sealing rope to seal between the burner tube or burner flange and the burner mounting plate. The burner mounting plate is refractory lined and is provided with the proper openings, holes, taps, etc. to mount the burner furnished with the boiler.

Carefully unpack the burner from its shipping container and check the contents. In case of shortage or damage, notify the transportation company immediately. **The envelope of papers enclosed with the burner is to be used, preserved, and turned over to the owner and/or the owner's representative.** Slip the gasket over the end of the burner blast tube and push it forward until it engages the burner mounting flange. Insert the end of the burner blast tube into the large opening in the burner mounting plate. Level the burner and firmly secure the burner mounting flange to the burner mounting plate using the bolts provided until a rigid installation is made. A gas-tight seal must be maintained between the burner mounting flange and the burner mounting plate or damage to the burner air tube will result.

CAUTION WIRING THE BOILER

The wiring diagram for the burner is packed in the burner envelope (sometimes located inside the control panel) or is affixed inside the door of the control panel.

All wiring should be installed in compliance with the rules of the National Electrical Code, or any local, state, or insurance requirements or codes having jurisdiction. Operating and safety circuit wiring must be No. 14 gauge wire. Power supply wiring to the burner must be No. 14 gauge or heavier, as required, and shall have a properly sized fused disconnect switch. Where the burner motor electrical current requirements are for voltages other than the control electrical current requirements, be sure the proper voltage is supplied to the controls, the burner motor, and any auxiliary equipment.

Follow the separate Burner Manual and Wiring Diagram for wiring the burner and the boiler controls.

FUEL LINE PIPING

Refer to the separate Burner Installation and Service Manual and any local or national code requirements which may apply to sizing and installing the fuel line piping.

Gas Piping:

The minimum inlet natural gas pressure required at the manual main shut-off gas valve is listed in the Burner Installation and Service Manual shipped with the burner. These gas pressures are for standard burners and are based on 0.60 specific gravity natural gas.

For other type gases, or for burners with additional equipment in the gas control assembly, refer to the material list packaged with the burner for the minimum recommended inlet gas pressure.

A main gas pressure regulator and a pilot line gas pressure regulator are furnished as standard equipment. For propane gas, a lock-up gas pressure regulator (furnished by the gas supplier) must be installed at the storage tank and should provide lock-up pressures not exceeding 14 inches water column.

The gas piping should be sized to provide the minimum required inlet gas pressure at the manual main shut-off gas valve when the burner is operating at the rated input. Consult the local utility regarding gas pressure, piping pressure drops, and any local gas piping requirements.

The gas piping should be installed in accordance with the specifications of the National Board of Fire Underwriters or National Fuel Gas Code and any additional code requirements which may apply. A drip leg should be installed at the inlet of the gas connection to the burner. Where the local utility requires that the drip leg be extended all the way to the floor, place an appropriate length of pipe between the cap and tee. All gas piping should be tested for leaks after installation with air pressure or inert gas of at least three times the gas pressure that will be used.

Fuel Oil Piping:

The rules of the National Board of Fire Underwriters and any local or national code requirements which may apply should be followed in locating and installing the fuel oil tank and the fuel oil piping. A two-pipe fuel oil piping system is recommended for all installations.

WARNING

If any part of the fuel oil tank is above the level of the burner, an anti-syphon device must be used to prevent the flow of oil in case of a break in the oil line. If the top of the fuel oil tank is below the level of the burner, use a check valve in the suction line on the burner side of the manual shut-off oil valve nearest the tank. An oil filter of the proper capacity is recommended for all installations.

Copper tubing should be used in preference to iron pipe as it has less possibility for leaks and does not scale off on the inside.

CAUTION

Flare type fittings are required.

The fuel oil piping from the tank to the burner should be sized no smaller than 1/2" O.D. copper tubing. Where the fuel

oil tank is located a considerable distance from the burner, the fuel oil piping should be sized to reduce the friction loss. An auxiliary fuel oil pump is recommended if the fuel oil suction line exceeds the length or lift published by the fuel unit manufacturer.

Connections to buried tanks must be made with swing joints to prevent the fuel lines from breaking in case the tank settles. If the job requirements stipulate that iron pipe must be used, swing joints made with elbows and nipples several inches long should be used on both the suction and return lines and located as close as possible to the tank. The swing joints should be installed so they will tighten as the tank settles.

A manual shut-off oil valve should be provided in the suction line near the burner and either at the tank or near where the suction line enters the building from an outside tank. If manual shut-off oil valves are located in the return piping, a by-pass relief to the tank with an oil pressure relief valve must be provided. The return line piping should be run to within 4 to 6 inches from the bottom of the tank.

Suction line piping should be pitched slightly toward the fuel storage tank whenever possible. Particular care should be exercised not to create an air trap in the suction line. There is always a slight amount of air in suspension in fuel oil and if traps are present, they will gradually fill with air and the fuel unit will lose its prime. It is good practice to provide a tee and plug at the highest point in the suction line to aid in priming the fuel unit.

WARNING

BOILER MUST BE GAS-TIGHT

For proper combustion efficiency and safety to the building occupants, **be sure the boiler is sealed gas-tight.** Remove top and side jacket panels. Shut off the breeching damper and start the burner, keeping it on prepurge. **Observe all sealing points and mark any that are not gas-tight.** Turn off the burner and open the breeching damper. Seal any areas that are not gas-tight by covering the outer surface of the sealing rope with silicone sealant. Replace the jacket panels.

CAUTION

BURNER AND BREECHING DAMPER ADJUSTMENT

Before firing the burner, lock the breeching damper in the open position. Start the burner and adjust the air band so that a clean yellow oil burner flame with slightly smoky tips or a clean gas flame is established.

Use combustion test instruments for final adjustment of the burner flame after the burner has advanced to high fire and the system water temperature has been raised to approximately the design conditions. A smoke reading of a trace to No. 1 on the Shell Bacharach scale is recommended with 11 1/2 to 12 1/2 percent CO₂ for No. 2 fuel oil. A CO₂ reading of 9 to 10 percent is recommended for natural gas. A test should be taken to assure that CO does not exceed .04 percent in the flue gases.

When the burner is on high fire and adjusted to the above conditions, adjust the breeching damper to provide a positive pressure of approximately +0.10 inches water column measured at the test opening on the draft hood collar. Secure the breeching damper by tightening the damper control swivels. Use the 1/8" brass plug to close the test opening in the draft hood collar after adjusting the breeching damper.

Where excess negative draft conditions prevail in the breeching between the chimney or vent and the breeching damper, it may be necessary to purchase and install a barometric draft control. Adjust the barometric draft control to provide approximately zero to -0.05 inches water column pressure between the breeching damper and the barometric control.

CAUTION

**CLEAN THE NEW
STEAM BOILER**

New steam boilers must be cleaned properly previous to or during the first few days of operation. Follow the cleaning rec-

ommendations listed on the START-UP, SERVICE AND MAINTENANCE INSTRUCTIONS. **Do not use chemical cleaners or PETROLEUM based products in this boiler!**

ADDITIONAL INSTRUCTIONS

Before leaving the job, make sure the unit checks electrically and the proper main burner flame is established. Be sure the thermostat heat anticipator is at the proper setting and the room thermostat or operating control is adjusted to provide the desired room temperature.

BOILER SERVICE AND MAINTENANCE

The boiler START-UP, SERVICE AND MAINTENANCE INSTRUCTIONS contain information for the owner. Review this information with the owner and/or the owner's representative and be sure they receive all instructions.



RATINGS . . . DATA

All Boiler and Auxiliary Equipment subject to change without notice.



Built to ASME specifications

Boiler Unit Number Steam or Water	I-B-R Burner Capacity Δ			Gross I-B-R Output BTU/Hr. +	Net I-B-R Ratings			Net Sq. Ft. Water ***	Boiler H.P.	Net Firebox Volume Cu. Ft.	Stack Gas Volume CFM****	Positive Pressure in Firebox □	I-B-R Chimney Size Vent Dia. Inches
	** Light Oil G.P.H.	Gas M.B.H.	Minimum Gas Pressure Required Inches W.C.○		Steam Sq. Ft.	Steam BTU/Hr.	Water BTU/Hr.						
▲486°F•	6.30	882	See gas burner manual accompanying this boiler	720,000	2,250	540,100	626,100	4,175	21.5	11.02	395	.34	10
▲586°F•	8.25	1,155		940,000	2,940	705,200	817,400	5,450	28.1	14.45	517	.35	10
▲686°F•	10.20	1,428		1,160,000	3,625	870,200	1,008,700	6,725	34.6	18.08	640	.35	10
▲786°F•	12.15	1,701		1,380,000	4,355	1,044,700	1,200,000	8,000	41.2	21.61	762	.36	12
▲886°F•	14.10	1,974		1,600,000	5,115	1,227,900	1,391,300	9,275	49.6	25.14	884	.37	12
▲986°F•	16.05	2,247		1,820,000	5,875	1,409,800	1,582,600	10,550	54.3	28.67	1,006	.38	14
▲1086°F•	18.00	2,520		2,040,000	6,600	1,583,900	1,773,900	11,825	60.9	32.20	1,128	.39	14
▲1186°F•	19.95	2,793		2,260,000	7,310	1,754,700	1,965,200	13,100	67.5	35.73	1,251	.40	14
▲1286°F•	21.95	3,073		2,480,000	8,025	1,925,500	2,156,500	14,375	74.1	39.26	1,376	.41	14
▲1386°F•	23.90	3,346		2,700,000	8,735	2,096,300	2,347,800	15,650	80.6	42.79	1,498	.42	14
▲1486°F•	25.90	3,626		2,920,000	9,445	2,267,100	2,539,100	16,925	87.2	46.32	1,623	.43	16
▲1586°F•	27.85	3,899		3,140,000	10,160	2,437,900	2,730,400	18,200	93.8	49.85	1,746	.44	16
▲1686°F•	29.75	4,165		3,350,000	10,835	2,600,900	2,913,000	19,420	100.1	53.38	1,865	.45	16

- Substitute "BGL" for light oil, "BGL" for gas-light oil, "BG" for gas. Add prefix "A" to designator for Factory-Assembled No. 86 (example: ABL).
- Substitute "S" for steam, "W" for water.
- For T-Intermediate section(s) and tankless heater(s) add suffix "(number required) TIH"; for T-Intermediate section(s) with cover plate(s) only add suffix "(number required) TIP".
- Δ Burner input based on maximum of 2,000 ft. altitude—for other altitudes consult Weil-McLain Application Engineering Department.
- ** No. 2 fuel oil—Commercial Standard Spec. CS12—48. Heat value of oil = 140,000 BTU/G.
- Gas pressure required at control inlet for rated burner input, based on 1,000 BTU/cu. ft., 0.60 specific gravity gas. Burners for different pressures and gases are available—consult Weil-McLain Application Engineering Department.

+ Gross I-B-R ratings have been determined under the I-B-R provision governing forced draft boiler-burner units.

‡ Net I-B-R ratings are based on net installed radiation of sufficient quantity for the requirements of the building and nothing need be added for normal piping and pick-up. Water ratings are based on a piping and pick-up allowance of 1.15. Steam ratings are based on the following allowances: 486 through 686—1.333; 786—1.321; 886—1.303; 986—1.291; 1086 through 1686—1.288. An additional allowance should be made for gravity hot water systems or for unusual piping and pick-up loads. Consult Application Engineering Department.

... Based on average water temperature of 170°F in radiators.

**** Stack gas volume at outlet temperature.

□ With 0.10" W.C. positive pressure at smoke collar. NOTE: Water boilers available upon special request at 80 P.S.I. working pressure.

DIMENSIONS (Inches)

SEE CONTROL TAPPING TABLE FOR DIMENSIONS NOT GIVEN BELOW

Boiler No.	Supply Tappings No. & Size*		Return Tappings No. & Size*		Dimensions (Inches)						
	Steam	Water	Steam	Water	A	B	C	D	E	L	W
486	2-5"	2-5"	2-6"	2-6"	23		23 3/8	10	54 3/4	32 1/4	30
586	2-5"	2-5"	2-6"	2-6"	31		31 3/8	10	54 3/4	40 1/4	38
686	2-5"	2-5"	2-6"	2-6"	39		39 3/8	10	54 3/4	48 1/4	46
786	2-5"	2-5"	2-6"	2-6"	47		47 3/8	12	53 3/4	56 1/4	54
886	2-5"	2-5"	2-6"	2-6"	55		55 3/8	12	53 3/4	64 1/4	62
986	2-5"	2-5"	2-6"	2-6"	63		63 3/8	14	52 3/4	72 1/4	70
1086	2-5"	2-5"	2-6"	2-6"	71		71 3/8	14	52 3/4	80 1/4	78
1186	2-5"	2-5"	2-6"	2-6"	79		79 3/8	14	52 3/4	88 1/4	86
1286	3-5"	2-5"	2-6"	2-6"	87	39 1/2	87 3/8	14	52 3/4	96 1/4	94
1386	3-5"	2-5"	2-6"	2-6"	95	47 1/2	95 3/8	14	52 3/4	104 1/4	102
1486	3-5"	2-5"	2-6"	2-6"	103	55 1/2	103 3/8	16	51 3/4	112 1/4	110
1586	3-5"	2-5"	2-6"	2-6"	111	63 1/2	111 3/8	16	51 3/4	120 1/4	118
1686	3-5"	2-5"	2-6"	2-6"	119	47 1/2	119 3/8	16	51 3/4	128 1/4	126

*Use Recommended Piping Connections.

