

SUBJECT: Welded Headers for Steam Boilers

A steam boiler cannot be correctly installed without proper near boiler piping. Proper near boiler piping is needed for steam separation, condensate return, and providing system flexibility during heating system heat up and cool down cycles. All of these issues are illustrated, and instructions and drawings must be followed, in the steam boiler installation manuals. The principles in this bulletin apply to both welded and threaded systems, but are highlighted for a better understanding of welded systems.

From a cold start, the steam boiler heats up to steam temperature before the near boiler piping begins to heat up. The near boiler piping begins to heat up after steam is flowing through the pipes. This difference in heat up timing results in the boiler expanding before the near boiler piping does. Incorrect near boiler piping can cause the boiler to begin to leak after the boiler starts up, and continue to leak until the header heats and catches up. The boiler can continue to operate without a leak as long as there is steam in the header. This short leaking period may not occur until the next heat up cycle.

Two threaded joints, in the proper orientation, are needed at each boiler connection. Each steam riser needs a swing joint, consisting of at least one elbow into the header and two threaded joints where the threads rotate in a horizontal direction—never pipe the risers straight up into the header. The equalizer piping needs two joints where the threads rotate in the vertical direction. To do this, the equalizer pipe is offset from the boiler return connection and a cross, or an elbow is used to allow the threaded joints to be placed the vertical position—this is illustrated in the boiler installation manual. Threaded joints must provide movement in the direction of the expansion. Without the movement, the threaded joint will not add any benefit.

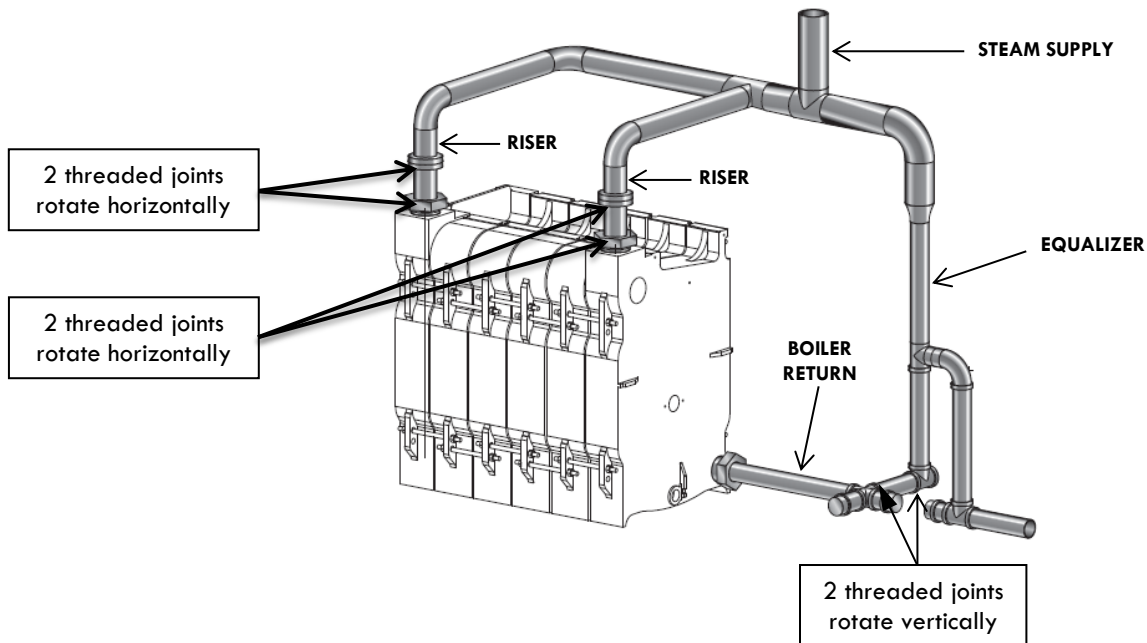

The near boiler pipe may be welded between the needed threaded joints. A threaded joint may not be replaced by a welded joint. The steam supply must be supported to allow movement.

If you have any technical questions regarding this, or any other Weil-McLain product, please feel free to contact us at 1-800-526-6636 (7:00 a.m. – 4:00 p.m. CST), or at vmtechnicalservices@weil-mclain.com