



Ultra *Gas-fired water boiler*

Conversion Instructions Natural to Propane Gas

STOP! Read this notice

NOTICE These instructions are only for propane conversion of a **boiler that has already been installed**. If you are converting a new boiler, not yet installed, do not use these instructions. Instead, read and follow all instructions in the Boiler Manual. Perform the propane conversion procedure on page 9 of the Boiler Manual only in the proper sequence.

These instructions are for conversion of the following boilers from natural gas to propane gas. (The propane gas orifice is located in the Propane Conversion Kit envelope.)

Boiler Model	Orifice stamping
Ultra-155	155-LP
Ultra-230	230-LP

WARNING **Ultra boilers are shipped ready to fire natural gas ONLY.** You must install the propane orifice if the boiler will be connected to propane. Follow all instructions in this document and the Boiler Manual. Failure to comply could result in severe personal injury, death or substantial property damage.

This conversion must be installed by a qualified installer/service technician in accordance with the Weil-McLain instructions and all codes and requirements of the authority having jurisdiction. The qualified agency performing this work assumes responsibility for this conversion.

Follow all instructions in proper order.

Do not tamper with orifice size. DO NOT change or modify orifice in any way.

Do not leave an uninstalled orifice in the building.

Verify the following before proceeding:

Propane gas operation requirements

Pipe sizing for propane gas

1. Contact propane gas supplier to size piping, tank and install a 100% lockup gas pressure regulator, or to verify size and condition of existing piping and equipment.

Propane supply pressure requirements

1. Adjust propane supply regulator provided by gas supplier for 13" w.c. maximum pressure.
2. Pressure required at gas valve inlet pressure port:
 - Maximum: 13" w.c. with no flow (lockup) or with boiler on.
 - Minimum: 4" w.c. with gas flowing (verify during boiler start-up per Boiler Manual).
3. After connecting propane gas line to boiler, and BEFORE operating, check gas pressure. If gas pressure is not in the range above, close manual gas valve and contact gas supplier to correct the problem before attempting to start or operate the boiler.



Ultra GAS-FIRED WATER BOILER — Propane Conversion Instructions

WARNING You must read and have the Ultra Boiler Manual with you to proceed with these instructions.

Install propane gas orifice

1. Turn off electrical power to boiler at external line switch or breaker.
2. Remove jacket front door by removing two knurled head screws at lower front.
3. Lift door away from boiler to remove.
4. Shut off gas to boiler by closing the manual gas valve (Figure 1).
5. Remove propane orifice disc from conversion kit envelope. Read the stamping on the orifice.

WARNING The orifice stamping must agree with the boiler size (see front page). DO NOT proceed with installation if orifice is incorrect. Installing the wrong orifice could result in severe personal injury, death or substantial property damage.

6. Disconnect the gas line union (Figure 1).
7. Remove (3) star-drive screws securing gas valve to venturi (Figure 2).
8. Place orifice in the black rubber grommet in the gas valve outlet port (Figure 2).
9. Reposition gas valve against venturi and replace (3) screws securing valve to venturi.
10. Reconnect gas line union.
11. DO NOT ADJUST gas valve pressure. See WARNING, bottom right.
12. Perform leak test and gas pressure checks given on page 19 of Boiler manual. Verify gas pressure at gas valve inlet pressure tap is in the range given on the front page of this document and in Boiler Manual.

Perform Boiler Manual start-up

WARNING Follow all instructions in Boiler Manual Section 7, pages 24 through 30, to start-up the boiler after converting for propane. Because the boiler has been changed, you must verify correct operation, including checking combustion with test instruments both at high fire and low fire as described in the Boiler Manual. Failure to comply could result in severe personal injury, death or substantial property damage.

Replace boiler jacket front door

WARNING Replace boiler jacket front door after servicing. The boiler front door must be securely fastened to the boiler to prevent boiler from drawing air from inside the boiler room. This is particularly important if the boiler is located in the same room as other appliances. Failure to keep the door securely fastened could result in severe personal injury or death.

Apply conversion label

1. After installation is complete, attach the propane conversion label (in instruction manual envelope) next to the boiler rating plate.

Figure 1 Gas component locations

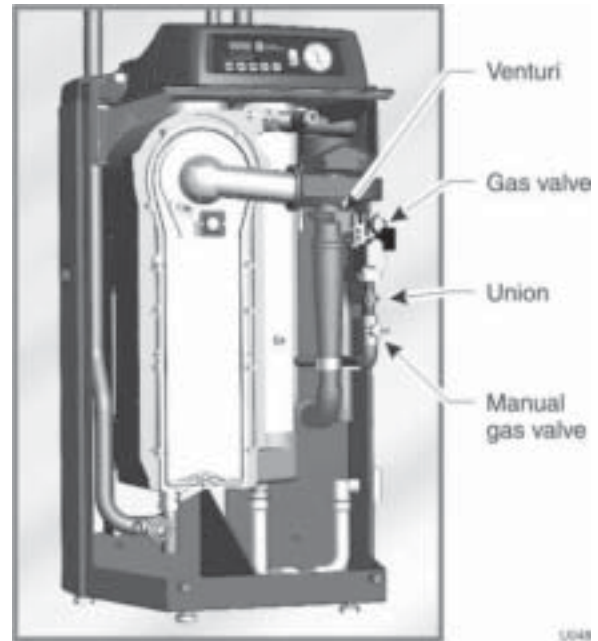
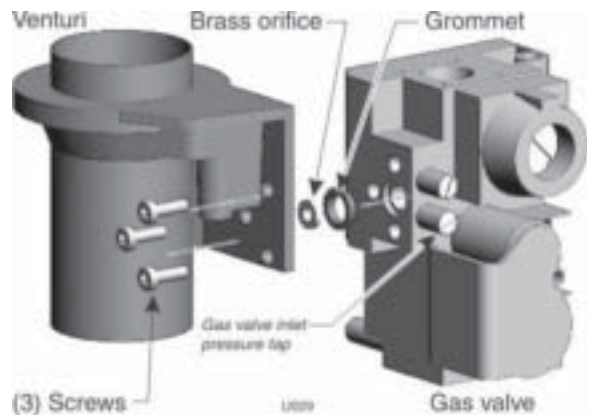

Figure 2 Installing propane orifice



WARNING DO NOT adjust or attempt to measure gas valve outlet pressure. The gas valve is factory-set for the correct outlet pressure. This setting is suitable for natural gas and propane, requiring no field adjustment. Attempting to alter or measure the gas valve outlet pressure could result in damage to the valve, causing potential severe personal injury, death or substantial property damage.