

Boiler installation is not complete until these instructions have been reviewed with the owner and are attached adjacent to the boiler

FOR YOUR SAFETY

Do not store or use gasoline or other flammable vapors and liquids in the vicinity of this or any other appliance.

WARNING: Improper installation, adjustment, alteration, service or maintenance can cause injury or property damage. Refer to this manual. For assistance or additional information consult a qualified installer, service agency or the gas supplier.

FOR YOUR SAFETY

**WHAT TO DO IF
YOU SMELL GAS**

- Do not try to light any appliance.
- Do not touch any electrical switch; do not use any phone in your building.
- Immediately call your gas supplier from a neighbor's phone. Follow the gas supplier's instructions.
- If you cannot reach your gas supplier, call the fire department.

1. Installation and service should be performed by a qualified service agency. Maintenance, as outlined in the suggested minimum maintenance schedule, can be performed by the boiler owner. Regular service and maintenance must be performed to assure maximum boiler operating efficiency.
2. To avoid electric shock, disconnect electrical supply before servicing.
3. To avoid severe burns, allow boiler to cool before servicing.
4. Do not block flow of combustion or ventilation air to boiler.
5. Should overheating occur or gas supply fail to shut off, do not turn off or disconnect electrical supply to pump. Shut off gas supply at a location external to boiler and call a service agency.
6. Do not store sources of contaminating chemicals in boiler area. Environments containing processes or store chemicals (such as spray cans with chlorides or fluorides, chlorinated waxes, cleaners or swimming pool chemicals, water softening calcium or sodium chlorides, refrigerants, paint removers, cements, glues, fabric softeners, or chloride type bleaches, detergents or cleaning solvents) can contribute to shortened boiler/vent system life.
7. Do not use this boiler if any part has been under water. Immediately call a qualified service technician to inspect the boiler and to replace any part of the control system and any gas control which has been under water.

BOILER WATER

1. Never use petroleum-based stop-leak compounds. Water seal deterioration will occur, resulting in leakage between sections.

2. DO NOT use "homemade cures" or "boiler patent medicines." Serious damage to boiler, personnel, and/or property may result.
3. Continual fresh make-up water will reduce boiler life. Mineral build-up in sections reduces heat transfer, overheats cast iron, and causes section failure. Addition of oxygen and other gases can cause internal corrosion. Leaks in boiler or piping must be repaired at once to prevent make-up water.

Boiler water pH of 7.0 to 8.5 is recommended.

For unusually hard-water areas or low pH conditions (below 7.0), consult local water treatment company.
4. DO NOT add large amounts of cold water to hot boiler. Thermal shock can cause sections to crack.
5. DO NOT drain boiler during periods of shutdown unless system is exposed to freezing temperatures or when antifreeze is used (see below). Repeated filling and draining has same effect as make-up water.

Freeze protection (when used):

Use antifreeze especially made for hydronic systems. Inhibited propylene glycol is recommended. DO NOT use undiluted or automotive type antifreeze.

50% solution provides maximum protection to about -30°F.

Local codes may require a back-flow preventer or actual disconnect from city water supply.

Determine quantity according to system water content. Boiler water content is listed in boiler manual.

Follow antifreeze manufacturer's instructions.

SUGGESTED MINIMUM MAINTENANCE SCHEDULE

Refer to following pages for detailed instructions.

Beginning of each heating season:

1. Annual service call by a qualified service agency.
2. Check burners and flueways for sooting. Use a mirror and flashlight to look up from base through sections. Call serviceman to clean, if necessary.
3. Visually inspect base insulation.
4. Visually inspect condensate drain trap and hose for proper operation or deterioration.
5. Visually inspect venting system for proper function, deterioration or leakage.
6. Check that boiler area is free from combustible materials, gasoline and other flammable vapors and liquids.
7. Check for and remove any obstruction to the flow of combustion or ventilation air to boiler.
8. Follow procedure "To Place in Operation."
9. Visually inspect burner flames.
10. Check operation of low water cut-off, if used, and additional safety devices. Refer to manufacturer's instructions.
11. Follow instructions on circulator to oil, if oil lubricated. Over oiling will damage circulator. Water lubricated circulators do not need oiling.

Daily during heating season:

1. Check that boiler area is free from combustible materials,

gasoline and other flammable vapors and liquids.

2. Check for and remove any obstruction to the flow of combustion or ventilation air to boiler.

Periodically during heating season:

1. Check safety relief valve. Reference manufacturer's instructions on relief valve tag.
2. Test low water cut-off, if used. Reference manufacturer's instructions.
3. Visually inspect condensate drain trap and hose for proper operation or deterioration.

Monthly during heating season:

1. Check for leaks in boiler and piping. If found, repair at once. DO NOT use petroleum based stop-leak compounds—leakage between sections will occur.
2. Visually inspect burner flames.
3. Visually inspect venting system for proper function, deterioration or leakage.
4. Check automatic air vent for leakage.

End of each heating season:

1. Follow "Annual Shutdown Procedure."

BOILER COMPONENTS

AUTOMATIC AIR VENT:

Vents air from built-in air vent tapping or high point of system.

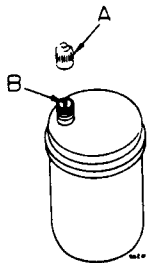

FLOAT TYPE AUTOMATIC AIR VENT

Maintenance (check periodically for leakage):

1. If leaking, remove cap A and push valve core B in by hand to clean valve seat.
2. Release valve B and replace cap A.
3. Unscrew cap two turns.

BLOWER MOTOR:

Operates blower to provide combustion air.

Maintenance (beginning of heating system):

1. Oil front and back blower motor bearing at oil cups with a few drops of S.A.E. 20 motor oil.

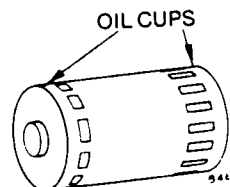

BLOWER MOTOR

WATER RELIEF VALVE:

Provides safety discharge if boiler water pressure exceeds 30 PSIG.

DANGER

To avoid water damage or scalding, relief valve outlet must be piped to a floor drain or near to the floor. Do not pipe to any area where freezing temperatures could occur.

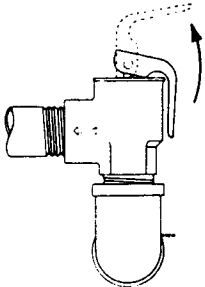

WATER RELIEF VALVE

Maintenance (check periodically for leakage):

1. If leaking, pull handle on relief valve and allow a small quantity of water to flow.

DANGER

Boiler water temperature must be low to eliminate potential of severe burns.

2. Be sure valve reseats properly and is entirely free from seepage.
3. If valve sticks or appears clogged, replace immediately.

CIRCULATOR:

Provides forced water circulation to system. Never operate without water.

Maintenance (beginning of heating season):

1. Oil lubricated—follow lubricating instructions found on circulation. NOTE: OVER OILING WILL DAMAGE CIRCULATOR.
2. Water lubricated—follow instructions found on circulator. Occasionally after a long period of shut-down, the impeller side of the circulator must be bumped lightly with your hand to get it started. If circulator has a plug on the outboard end, remove plug and give the shaft a twist with a screwdriver. Replace plug.

EXPANSION TANK:

Provides space for increased water volume as water is heated. May be open, closed or closed-diaphragm type.

1. Open type—Located above highest heat distributing unit, usually in an attic or closet. Has a gauge glass and an overflow pipe to a drain.
2. Closed type—Welded gas tight and located anywhere in the system. Tank is partially filled with water, leaving an air cushion for expansion.
3. Closed diaphragm type—Welded gas tight with a rubber diaphragm to separate air from water. May be located at any point in heating system but is usually close to the boiler. When used, an air vent must be installed in air vent tapping on boiler to eliminate system air. Before filling the system, tank should be charged with air (use a tire pump) to a pressure equal to desired initial fill pressure. Normal cold fill pressure for a residential system is 12 PSIG. Tank pressure may be checked with an air pressure gauge. When heated, water expansion causes the diaphragm to push against the air cushion, providing space for additional water volume.

Maintenance (if necessary):

1. If relief valve opens frequently, expansion tank may be waterlogged. Call a trained serviceman to drain the tank and re-establish proper air cushion.

HIGH TEMPERATURE LIMIT CONTROL:

In case of high boiler water temperature, shuts down burners but lets circulator run as long as there is a call for heat. Limit should be set higher than the design temperature of the system. Maximum setting is 220°F. Setting may be raised or lowered according to individual system requirements.

COMBINATION PRESSURE/TEMPERATURE GAUGE:

Provides readings of boiler water pressure and temperature. In general, cold fill pressure for residential systems is 12 PSIG. As the water heats, the pressure will rise. Maximum pressure is 30 PSIG. System temperature will vary according to system design and daily heating demands. Temperatures will range from room temperature to the high limit setting, which can be adjusted to a maximum of 220°F.

MAINTENANCE PROCEDURES

FILL THE SYSTEM

1. Close manual air vents, drain cock, and automatic air vent, if used.
2. Fill to correct system pressure.
3. Open automatic air vent two turns, if used.
4. Heat to approximately 210°F for 15 minutes to drive off dissolved gases. The high limit should be set above 210°F.
5. Check system piping for leaks. If found, repair immediately. DO NOT use petroleum based stop-leak compounds or leakage between boiler sections will occur.
6. Air must be vented from the system. System air can interfere with water circulation and cause improper heat distribution.
 - a) Open manual water feed valve.
 - b) Starting on lowest floor, open air vents one at a time until water squirts out. Close vent.
 - c) Repeat with remaining vents.
 - d) Close manual water feed valve when correct boiler pressure is reached.

INSPECT VENTING SYSTEM

1. Inspect venting system at least once a month during heating season.
2. Check gas-tight seal at all vent pipe connections. Call serviceman to correct any joints that are not gas-tight.
3. Inspect all parts of venting system for deterioration from corrosion, physical damage, sagging, etc. Correct all conditions found.

INSPECT BASE INSULATION

Make sure base insulation is secure against all four sides of base. If refractory material is damaged or displaced, call serviceman immediately. **DO NOT** operate boiler.

CAUTION

Ceramic fiber material used in boiler base insulation and gaskets can cause temporary skin, eye, and upper respiratory irritation.

Use NIOSH or MSHA approved protection when installing or removing this material.

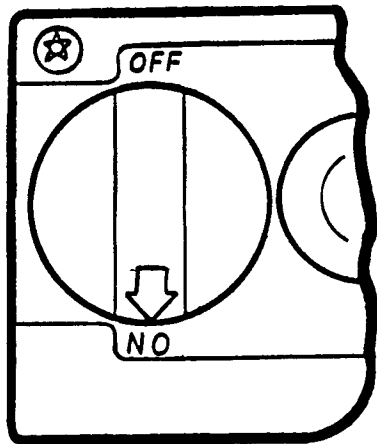

GAS COCK KNOB

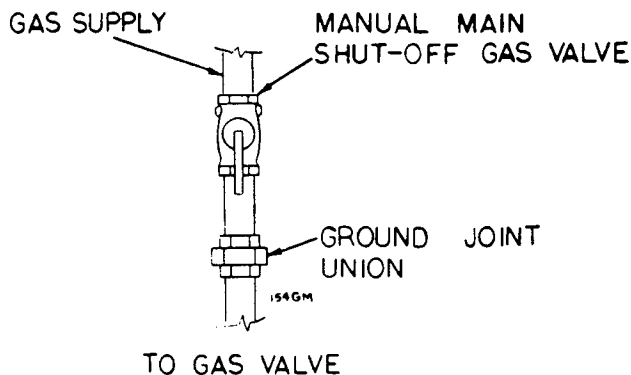

MANUAL MAIN SHUT-OFF GAS VALVE

TO PLACE IN OPERATION

CAUTION

Manual gas cock knob and manual main shut-off gas valve (when used) must be closed at least five (5) minutes before lighting.

1. Be sure boiler has been correctly filled with water.
2. Turn ON electric power.
3. Open manual gas cock knob, when used.
4. Open manual main gas valve, when used.
5. Move thermostat or operating control to call for heat.
6. If boiler starts, go to Step 8.
If boiler fails to start, go to Step 7.
7. If boiler fails to start, check for following conditions:
 - a) Loose connection or blown fuse?
 - b) High limit set below boiler water temperature?
 - c) Thermostat set below room temperature?
 - d) Gas not turned on at meter and boiler?
 - e) Access panel not secured in place?
 - f) If above fails to eliminate the trouble, call a trained serviceman.
8. Make sure boiler goes through several normal operating cycles.
9. Turn thermostat or operating control to desired setting.

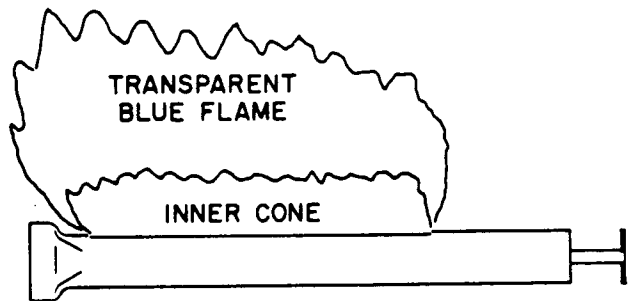

TYPICAL MAIN BURNER FLAME

CHECK MAIN BURNER FLAMES

1. Check main burner flames at least once a month during heating season.
2. Proper burner flame, see illustration above. Yellow-orange streaks may appear—caused by dust.
3. Improper burner flame:
 - a) Overfired—Flames large.
 - b) Underfired—Flames small.
 - c) Lack of primary air—Yellow tipping on flames; sooting will occur.
4. If improper burner flames are suspected, contact a trained serviceman or local gas utility.

W

CLEANING BOILER HEATING SURFACES

P
P

After each heating season, remove front access panel to inspect burners and flues. Use a mirror and flashlight to look up from base through sections. If soot is found, contact your serviceman to clean. **The following cleaning procedure should only be done by a qualified heating contractor.**

1. Shut down boiler.
2. Remove top jacket panels. Remove front and interior jacket panels.
3. Remove flue collector cover A and front cleanout cover B.

CAUTION

Ceramic fiber material used in boiler base insulation and gaskets can cause temporary skin, eye, and upper respiratory irritation.

Use NIOSH or MSHA approved protection when installing or removing this material.

4. Remove burners. Vacuum or brush to remove dust and lint.

NOTICE

Ignitor is fragile. Handle with care.

5. Thoroughly clean heating surfaces with a flue brush.
 - a) Clean bottom through base.
 - b) Clean middle through cleanout port.
 - c) Clean top through flue collector.
 - d) Clean VHE heat exchanger with water and/or compressed air. **Check drain for operation after cleaning.**
6. Remove soot from boiler.
7. Replace burners.

WARNING

When replacing, burner tubes must be seated in the slots in the back with the openings facing up.

8. Replace flue collector cover and cleanout cover. Reseal with silicone sealant.
9. Replace jacket panels.
10. Start boiler following start-up procedure.
11. Check base insulation and main burner flames for proper operation.

ANNUAL SHUT-DOWN PROCEDURE

1. When used, close manual main shut-off valve, and gas cock on gas valve.
2. Disconnect electric power supply.
3. Move thermostat indicator to low setting.
4. **DO NOT** drain system unless exposure to freezing temperatures will occur. If antifreeze is used, do not drain.
5. Open boiler drain cock to remove impurities that may have settled in boiler (about a quart is all that is necessary to drain). Refill to correct pressure.

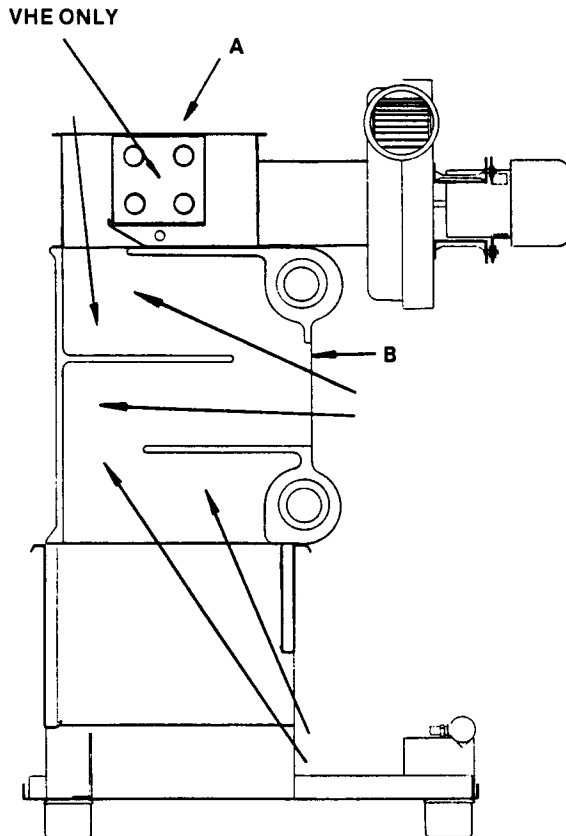

CLEANING BOILER HEATING SURFACES

COMMON PROBLEMS AND POSSIBLE SOLUTIONS

COMMON SYMPTOMS	COMMON CAUSES	POSSIBLE CORRECTIONS
Rapid cycling—burners turn on and off frequently.	Unlevel thermostat.	Level thermostat. Refer to instructions with thermostat.
	Thermostat installed where drafts or heat affect reading.	Locate thermostat on inner wall away from heat sources or cool drafts.
	Heat anticipator in thermostat adjusted incorrectly.	Adjust heat anticipator to match current draw. Refer to boiler wiring diagram.
	Incorrect limit setting.	Set limit according to system design. Maximum setting is 220°F. Increase limit setting to decrease cycling.
Frequent release of water through the relief valve.	Insufficient expansion tank size.	Call installer to check expansion tank operation.
	Flooded expansion tank.	Call installer to check expansion tank operation.
Need to frequently add make-up water.	Leaks in boiler or piping.	Have installer repair leaks at once to avoid constant use of make-up water. Make-up water can cause mineral deposits which, in turn, can cause boiler section failure. Do not use petroleum based stop-leak chemicals.
Popping or percolating noise heard in boiler.	Mineral deposits in sections due to constant use of make-up water.	Call installer to delime boiler, if necessary. In some cases deposits will be too heavy to remove with deliming.
		Have installer repair leaks to eliminate the need for constant make-up water.
	Incorrect pH of boiler water.	pH should be maintained at 7.0 to 8.5
Metal flakes found in boiler base—flueway corrosion.	Halogenated hydrocarbons from environment contaminating the combustion air.	Locate and remove sources of hydrocarbons (i.e., bleaches, cleaners, chemicals, sprays, fabric softeners, paint remover, etc.).
	Condensation of combustion gases in cast iron sections of boiler.	Set high limit above 140°. If high limit is already above 140°, consult installer for by-pass piping recommendations.
Isolated radiation does not heat	Air in system.	Bleed air from system through vents in radiation.
	Low system pressure.	Fill to correct pressure.
		Check for leaks in boiler or piping. Have installer repair at once.
High limit set too low.	Adjust high limit to a higher setting.	
Black Water Condition	Oxygen corrosion due to leaks in boiler and piping.	Have installer repair at once. Keep pH of water between 7.0 to 8.5.

WEIL-McLAIN®

Michigan City, Indiana 46360 ■ A Marley Company



In Canada: Marley Fluid Systems, 126 East Dr., Brampton, Ontario L6T 1C2

