



WEIL-McLAIN

GOLD GV

Water Boiler — Series 1 – 4

Blower Assembly or Burner Replacement Instructions

For use with Weil-McLain Kit part numbers:

382-200-340 — GV Blower housing assembly replacement kit

382-200-300 — GV Front section repair parts kit

382-200-320 — GV-3 Burner replacement kit

382-200-325 — GV-4 Burner replacement kit

382-200-330 — GV-5 Burner replacement kit

382-200-335 — GV-6 Burner replacement kit

Recommended tools:

- 10" crescent wrench
- small pipe wrench
- $\frac{5}{16}$ " nut driver
- $\frac{5}{16}$ " socket with extension
- $\frac{1}{2}$ " socket with extension

Hazard definitions

The following defined terms are used throughout these Instructions to bring attention to the presence of hazards of various risk levels or to important information concerning the life of the product.



Indicates presence of hazards that **can cause severe** personal injury, death or substantial property damage.



Indicates presence of hazards that **will or can cause minor** personal injury or property damage.

NOTICE

Indicates special instructions on installation, operation or maintenance that are important but not related to personal injury or property damage.

To the installer:

These Instructions must only be used by a qualified installer/service technician. Read these Instructions completely before beginning the installation. Failure to follow all instructions can cause severe personal injury, death or substantial property damage.



Parts

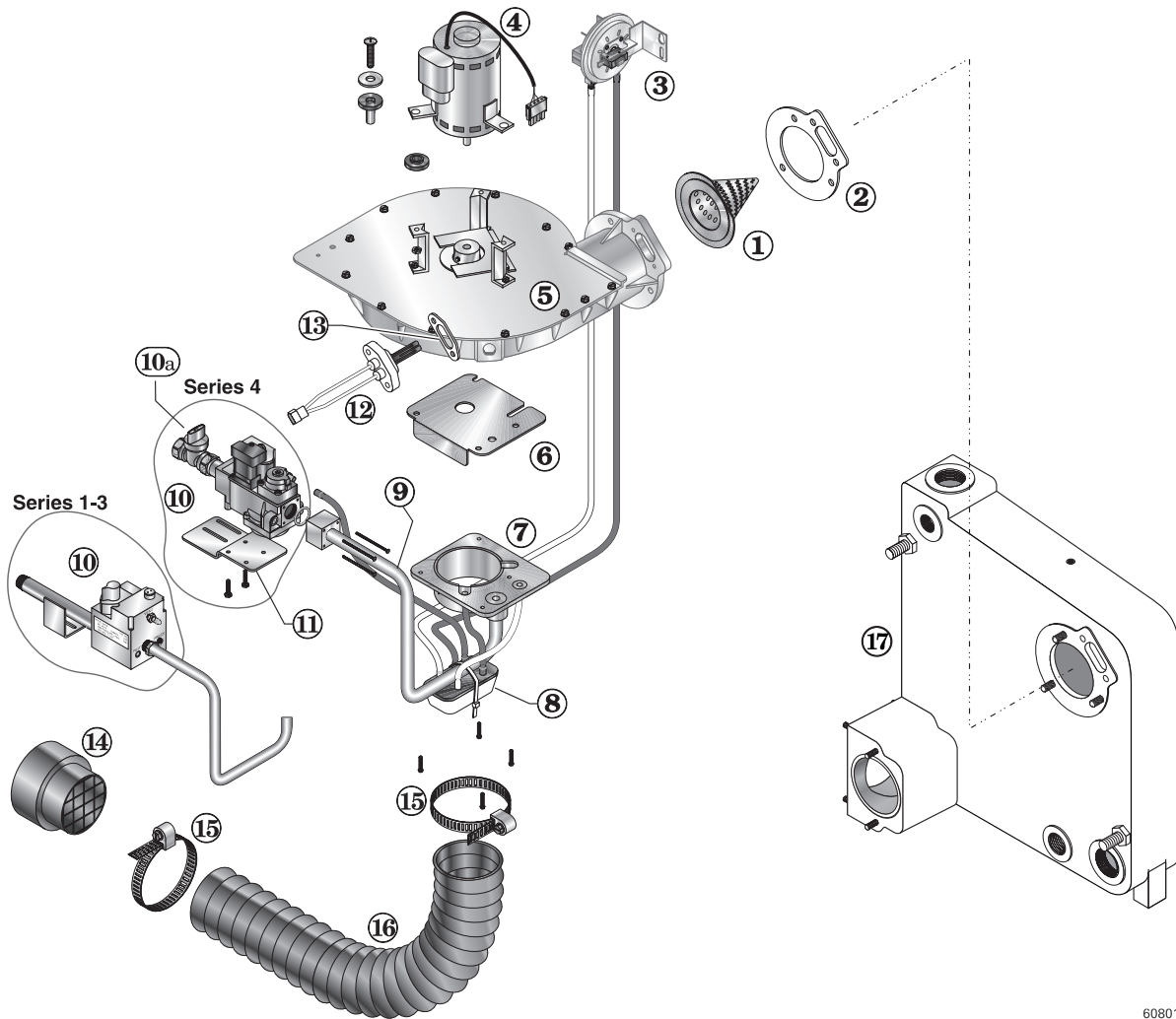

60801

Item number	Description	Weil-McLain kit part number
1	Burner replacement kit (includes: burner cone and ring assembly, blower flange gasket, igniter, igniter screws, igniter washers, igniter gasket) GV-3 GV-4 GV-5 GV-6	382-200-320 382-200-325 382-200-330 382-200-335
2	Blower flange gasket	
3	Air pressure switch (0-5,500 feet elevation)	
4	Blower motor replacement kit (includes: blower motor, motor mount grommets, screws, lock nuts, 9" Allen wrench)	382-200-345
5	Blower housing assembly replacement kit (includes: blower housing, observation port window, blower housing cover plate, blower motor mounting brackets, washer hold down bracket, lock nuts, motor mount grommets, blower motor, blower wheel, magnetic washer, silicone sealant, screws, blower flange gasket, igniter, igniter screws, igniter washers, igniter gasket)	382-200-340
6	Orifice plate	

Item number	Description	Weil-McLain kit part number
7	Gas/air manifold assembly (includes: gas/air manifold, gas tubing, washers, screws, gas valve o-ring)	
8	Condensate trap kit (includes: condensate trap, hoses)	
9	Gas valve tubing (turn clockwise to loosen)	
10	Gas valve kit (includes: gas valve, gas cock, ½" nipple, bracket, screws and o-ring)	
10a	Gas cock, ½" NPT	
11	Gas valve bracket with screws	
12	Igniter replacement kit (includes gasket)	
13	Igniter gasket (included in item 12, above)	
14	Inlet air fitting	
15	Hose clamp, 3"	
16	Inlet air hose	
17	Front section repair parts kit (includes: square cut seals - 2", silicone sealant, tie rod nuts, tie rod washers, water tubing male adapters - 1" NPT, water tubing, pump to return, blower flange gasket, igniter, igniter gasket, screws, studs, nuts, lock washers)	382-200-300



Replacement instructions

⚠ WARNING

Shut off main gas valve and disconnect electricity to boiler. Failure to do so can cause severe injury, death or substantial property damage

⚠ WARNING

Wait until igniter is cooled down before proceeding. Failure to do so can cause severe injury.

⚠ WARNING

Do not disassemble blower housing. A fire or explosion causing severe personal injury, death or substantial property damage could result.

To remove blower assembly or burner

1. Remove jacket top and front panels.
2. Remove control tray shipping screw and lift up control tray, setting it out of your way (Series 1 and 2). Remove gas supply piping.
3. Disconnect (refer to items identified on page 2):
 - a. gas tubing from gas valve (left-hand thread - Series 1-3) (4 screws - Series 4), item 9
 - b. pressure switch hoses, item 3
 - c. hose from gas valve to gas/air manifold, item 7
 - d. inlet air hose, item 16
 - e. blower motor wiring harness from control module
 - f. igniter harness from igniter plug
 - g. blower support bracket
 - h. gas supply manifold with bracket from blower housing
 - i. ground wire from blower housing
 - j. gas/air manifold and orifice plate, items 6 and 7.
4. Remove 2 igniter screws and lockwashers. Carefully remove igniter, item 12.

⚠ CAUTION

Use care when removing and handling igniter. Igniter is very brittle and can break if not handled carefully. **Do not touch!**

5. Remove nuts and washers from studs at blower housing mounting bracket and casting.
6. Grasp blower assembly and pull free from studs. Turn clockwise until blower assembly can be removed safely from inside of boiler.
7. Pull out burner cone and ring assembly and old gasket, items 1 and 2, to inspect for dust or soot accumulation. Clean or replace as necessary.

To install blower assembly or burner

1. Place new blower housing gasket over studs at combustion chamber opening.
2. Re-install burner cone and ring assembly into combustion chamber.
3. Position blower assembly over studs. Install nuts and washers and tighten until blower housing gasket starts to compress.
4. Install igniter and new igniter gasket. Fasten with screws and washers. Tighten until lockwasher starts to compress.

NOTICE

Igniter body will crack if screws are over-tightened.

5. Replace control tray.
6. Connect:
 - a. Gas/air manifold and orifice plate (tighten screws until metal-to-metal contact is made around entire manifold)
 - b. Gas tubing from gas valve (left-hand thread - Series 1-3) (4 screws - Series 4)
 - c. Pressure switch hoses
 - d. Hose from gas valve to gas/air manifold
 - e. Inlet air hose (tighten hose clamp)
 - f. Blower motor wiring harness to control module
 - g. Igniter harness to igniter plug
 - h. Blower support bracket
 - i. Gas supply manifold with bracket to blower housing
 - j. Ground wire to blower housing.
 - k. Gas supply piping
7. Be sure all wiring and hose connections are secure and in their proper locations.
8. Turn on electrical power and gas. Check boiler normal sequence of operation and follow check-out procedure in Boiler Manual.
9. Replace jacket front and top panels.



Weil-McLain
500 Blaine Street
Michigan City, IN 46360-2388
<http://www.weil-mclain.com>